

OWNER'S MANUAL



CLASS B
MOTORHOMES

⚠ WARNING

Operating, servicing and maintaining a passenger vehicle or off-road vehicle can expose you to chemicals including engine exhaust, carbon monoxide, phthalates, and lead, which are known to the State of California to cause cancer and birth defects or other reproductive harm. To minimize exposure, avoid breathing exhaust, do not idle the engine except as necessary, service your vehicle in a well-ventilated area and wear gloves or wash your hands frequently when servicing your vehicle.

For more information go to: www.P65Warnings.ca.gov/passenger-vehicle



Read this manual carefully before operating this vehicle. This manual should stay with the vehicle if it is sold.



OWNER'S *MANUAL*

CLASS B MOTORHOMES

Congratulations with the ownership of your new motorhome and welcome to the wonderful world of RV'ing and to the Thor Motor Coach family of recreational vehicles.

We sincerely thank you for choosing the Thor Motor Coach brand. Our mission is to produce quality motorized recreational vehicles designed to provide you with carefree, comfortable travel and vacationing for now and for many years to come. We are confident that you will find your new motorhome is 'Made to fit' your recreational aspirations.

Your motorhome was built following the high standards set by Thor Motor Coach (TMC), the Recreational Vehicle Industry Association (RVIA), and (if applicable) the Canadian Standards Association (CSA) as well as complying with the requirements of all applicable state and federal agencies at the time of manufacture.

Our customers are extremely important to us, and we assure you that TMC will always strive to do everything possible to earn and retain your trust and goodwill.

Happy Travels!

THOR MOTOR COACH
P. O. Box 1486
Elkhart, Indiana 46515-1486

(Toll Free) 877.855.2867

www.thormotorcoach.com

Thor Motor Coach (TMC) reserves the right to make changes in vehicles built and/or sold at any time without incurring any obligations to make the same or similar changes on vehicles previously built and/or sold by TMC. Information in this owner's manual is subject to change without notice and represents information relevant at the time this version was printed. Nothing in this owner's manual creates any warranty, either expressed or implied. The only warranties offered are those set forth in the Thor Motor Coach Limited Warranty and in the Thor Motor Coach Structural and Lamination Limited Warranty, as applicable to the motorhome.

Table of Contents

Section 1: Introduction

About This Owner's Manual	9
TMC Warranty Guide	9
Chassis Manufacturer's Owner's Manual and Warranty	9
TMC Owner's Packet	9
Contact TMC Customer Care	9
Online Customer Support	10
TMC Owners Resource	10
TMC System Guides	10
TMC Instructional Videos	11
TMC Basic Operation Guides	11
Link to TMC Owners Resource	11

Section 2: Consumer Information

Dealer's Responsibilities	13
Consumer's Responsibilities	13
Change of Address or Ownership	14
Vehicle Identification Labels	14
How to Obtain Assistance	14
Suggestions for Obtaining Service	14
Emergency Weekend or After Business Hours	
Warranty Repair Assistance	15
Obtaining Service Repair at Thor Motor Coach	15
Replacement Parts	15
Website Usage Disclaimers	16
Website Disclaimer of Warranty	16
Disclaimer of Endorsement	16
Thor Motor Coach® Recreational Vehicle	
Privacy Notice	16
Chassis Manufacturers Notice	17
Reporting Safety Defects	17
In the United States	17
In Canada	17

Section 3: Vehicle Safety

Safety Alerts	19
Safety Labels	19
Fire Safety	19
Basic Rules of Fire Safety	20
Fire Extinguisher	20
Smoke Alarm	21
Carbon Monoxide (CO)	22
Exhaust Fumes and Gases	22

Propane Safety	23
Combination Carbon Monoxide/Propane Alarm	24
What to do if the alarm sounds:	24
Fuel System Safety	25
Emergency Exit	25
Front Airbags	26
Driver and Front Passenger Seats	26
Seatbelts	26
Child Passenger Safety	27
Transporting Pets	28
Mirrors and Vision Systems	28
Mirrors	28
Vision Systems	28
Laws of the Road	29
Clearance and Side Marker Lights	29
Emergency Stopping	29
Chassis Manufacturer's Vehicle Safety Features	29
Safely Driving the Motorhome	30
Chemical Sensitivity	31
Ventilation	31
Formaldehyde	31

Section 4: Tires and Wheels

Tire Safety	33
Tire Inflation and Inspection	33
Checking Tire Pressures	33
Inspect the Condition of Your Tires	34
Common Tire Wear Patterns	34
Lug Nut Torque	35
Changing a Damaged Tire	35
Wheel Alignment	35
Tire Replacement	35
Tire Identification Information	36

Section 5: Weighing, Loading, and Towing

Introduction	37
Important Weight Terminology	37
Federal Weight Label	38
Occupant and Cargo Carrying Capacity	
Weight Label (OCCC)	39
Alterer Label (USA)	39
Canadian Weight Label / Statement of Compliance	40

TABLE OF CONTENTS

Canadian Cargo Carrying Capacity Label 40
 Canadian Recreational Vehicle Length Label 41
 Alterer Label (Canada) 41
 CMVSS Label 41
 Weighing Your Motorhome 42
 Weight Distribution 43
 Loading Your Motorhome 43
 Towing With Your Motorhome 43
 Towing Hitch 44
 Electrical Connections for Towing 44
 Safe Towing Tips 45

Section 6: Exterior Features and Components

Awning 47
 Lighted Entry Step (if equipped) 48
 Roof 48
 Roof Rack (if equipped) 48
 Light Bar 48
 Rear Door Screen (if equipped) 49
 Bicycle Rack (if equipped) 49

Section 7: Interior Features and Components

Interior Lighting 51
 Powering the Lighting System 51
 Appliances 52
 Cooktops 53
 Refrigerators 53
 Microwave and Microwave/Convection Ovens 54
 Entertainment Systems 55
 Dash Radio and Multimedia Receivers 55
 Television 55
 Cable TV Hook-up 55
 Cable and Over-the-Air TV 55
 Wi-Fi Connectivity: 4G System 57
 Wi-Fi Connectivity: 5G System 58
 Interior Furniture 59
 Beds and Bunks 59
 Dinette and Work Surface Tables 60
 Convenience Tables 61
 Lagun® Table System 62
 Storage 63
 Over-cab Storage 63
 Lockable Storage Compartment 64

SkyBunk® (optional) 65
 Before Raising the Top 66
 Raising the Top 67
 Opening the Side and Front Windows 67
 Lowering the Top 68
 Tips for Safe Use 68
 Canvas Care 69
 Safety Nets 69

Section 8: Rapid Camp+® Multiplex Control Systems

Introduction 71
 Control Panels 72
 Wireless Switch Panels 72
 Main Electrical Control Boards 73
 Basic Multiplex Operation 74
 Remote Control 74
 Additional Multiplex Systems Information 74
 Firefly Screen Navigation 75
 Firefly Phone App 76
 Vegatouch Mira and Eclipse Setup 76
 App Settings: 78
 Firefly Diagnostic Tools 79
 Description of BMPPro RVDM50 Control/Display 80
 Rapid Camp+® System Diagram 81
 Basic Operation: 82
 The RVMaster Smartphone App 83
 Pairing to the RVMaster Node: 83
 Pairing a Wireless Switch to the RVMaster Node 84
 Configuring the Motorhome Using a Smartphone 84
 Faults and Warnings on the RVDM50 Display 84
 BMPPro Cloud 85
 Remote Switch (Master Switch) 86
 Winegard 4G 2.0 Wi-Fi Extender 87

Section 9: Electrical System

12 Volt Power System Introduction 89
 Master Battery Switch 89
 Auxiliary Battery(ies) (Lead-Acid) 90
 Emergency (Auxiliary) Start Switch 91
 Chassis Alternator 91
 Battery Access 91
 Battery Charging 92
 Charging by the Vehicle's Alternator 92
 Charging by the Converter 92
 Charging by Solar Energy 92

Solar Charging, 10 amp Controller 93

Integrated Solar Charging Systems 94

Solar Panels 95

 Auxiliary Solar Panel Port 95

Battery Maintenance: Lead Acid Type 96

 Battery Storage (Lead Acid or AGM) 97

 Battery Replacement 97

Inverter (Non-Lithium Battery Systems) 97

 Inspection and Maintenance 98

Re(Li)able® Battery Power Systems 99

 Introduction 100

 Safety Guidelines 101

 Basic System Operation 101

 Re(Li)able® V2, 400 Amp-Hour System 102

 Victron Energy Battery Monitor 106

 Ford Transit Vans Only: Idle Speed Control 109

 Re(Li)able® V1, 460 Amp-Hour System 111

 Safety Relays 113

 Battery Charging 114

 Battery Storage 115

 Engine Auto-Start Charging System (optional) 115

MasterAdjust Software and Remote System

Servicing - 460 Ah System 118

 Long-term Storage of the Re(Li)able®
 400 Ah Battery Systems 119

 Long-term Storage of the Re(Li)able®
 460 Ah Battery System 121

120-volt Power System 123

Shore Power 123

 30-amp, 120-volt Shoreline Power Cord 124

 Connecting to an External Power Source 124

 Shore Power Wiring Configuration 125

 Shoreline Cord Plug Adapters 125

 Trickle Charging Batteries During Storage 126

 Incoming Power Protection 126

 Shore Power Cord Maintenance 126

 Power and Electrical Accessories 126

Generator (if equipped) 126

 Starting and Stopping Procedures 127

 Automatic Generator Start (if equipped) 128

 Generator Access 129

Automatic Transfer Switch (if equipped) 129

Power Load Center: 30-amp 130

 120-volt Circuit Breaker Panel 130

 12-volt Fuse Panel 131

 Converter (if equipped) 132

GFCI Receptacle 133

Outside 120-volt AC Receptacle 133

Section 10: Propane System

Propane Gas Safety 135

Introduction 136

Traveling With Propane 136

Propane Tank 137

 Monitoring Propane Levels 137

 Filling and Servicing the Propane Tank 137

Using the Propane System 138

 Main Gas Valve 138

 Furnace/Water Heater Gas Shut-off Valve 139

External Propane Hook-up 139

Propane Leak Test 141

Section 11: Water System

Freshwater System 143

Potable Water Hose 143

City Water Connection 143

Freshwater Holding Tank 144

 Gravity Fill Port 144

 Freshwater Holding Tank Drain Valve 145

Water Pump 145

 Water Pump Strainer 145

Freshwater Filter 146

Rear Convenience Panel 146

 Exterior Spray Port 146

Kitchen Sink 146

Bathroom and Bath Fixtures 146

 Bathroom sink operation 146

 Shower operation 147

Furnace/Water Heater Combo 147

 Water Heater Bypass Valves 148

Low Point Drain Valves 148

Holding Tank Heaters (if equipped) 149

Water System in Cold Weather 149

Sanitizing the Freshwater System 150

Winterizing the Water System 151

 De-winterizing the Water System 152

Wastewater System 153

Toilet 153

 Cassette Toilet (if equipped) 153

Wastewater Holding Tanks 154

Termination Valves and Sewage Discharge 154

 Portable Toilet 154

TABLE OF CONTENTS

Campsite Sewer Hook-up 155

Emptying Wastewater Holding Tanks 155

 Gray Wastewater Tank 156

 Emptying the Toilet Cassette 157

Black Tank Rinse (if equipped) 158

Section 12: Heating and Cooling

Introduction 159

Truma Combination Furnace/Water Heater 159

 Safe Operational Procedures 160

 Operating Instructions 161

 Gas Shut-off Valve Switch 162

 Room Temperature Sensor 162

 Truma Pressure Relief/Drain Valve 162

 Starting the Combi Furnace 163

 Filling the Water Container 164

 Switching ON the Furnace 164

 Switching OFF the Furnace 164

 Draining the Water Container 165

 Winterizing 165

 Winter Operation 166

 Maintenance and Storage 166

Aqua-Hot Combination Furnace/ Water Heater . . . 167

 Safe Operational Procedures 167

 Operational Notes 168

 Winterizing 168

 Maintenance and Storage 168

Furnace/Water Heater Controller 169

 Description 169

 Display and Operating Elements 169

 Controller Operation 170

Roof Air Conditioner 174

 General Information 174

Cabinet Air Conditioner 175

Ceiling and Ventilation Fans 175

Section 13: Care and Maintenance

Chassis (Vehicle) Maintenance 177

General Maintenance 177

Mold Prevention 177

 Inhibiting Mold Growth 177

Condensation 178

 Tips for Controlling Condensation 178

Seals and Sealants 178

Cleaning Interior and Exterior Surfaces 178

Extreme Weather Use 178

Extended Stay Usage 179

Long-term Storage of Your Motorhome 180

 General Vehicle Preparation 180

 Exterior 181

 Interior 182

Additional Care and Maintenance Information . . . 182

Maintenance Schedule 183

Index 189

This page is intentionally blank

This page is intentionally blank

Section 1 : Introduction

About This Owner's Manual

This Owner's Manual is intended to introduce you to the basic features of your new motorhome. It is not intended for use as a service manual, nor does it provide complete operational instructions. It is a guide to help you become familiar with the safe operation and use of your motorhome. It is general in nature, so the illustrations and descriptions provided may differ from the actual components installed in your motorhome. Please read and keep it, along with your TMC Warranty Guide, your TMC Owner's Packet, and the vehicle owner's manual in your motorhome for needed reference.

Specific information for the systems and components of your motorhome is provided through other TMC publications, media, and services. These resources include: TMC on-line Owners Resource service, which provides owners with access to component manufacturer's instructional booklets and other important documents, TMC-produced how-to videos, and through TMC's Customer Care representatives, who are available 24/7 to answer your questions and assist with your concerns.

TMC Warranty Guide

The Thor Motor Coach Limited Warranty is printed in your TMC Warranty Guide. The TMC Warranty Guide also contains your TMC Product Warranty Registration Form and other important information.

Please review all warranties, warranty restrictions, limitations, and actions needed to keep warranties in-force with your dealer. If you have questions regarding TMC Warranty coverage, contact TMC Customer Care.

Electronic copies of this owner's manual and the Thor Motor Coach Class B Warranty Guide are available from the Thor Motor Coach website:

www.thormotorcoach.com/owners/owners-manuals

Chassis Manufacturer's Owner's Manual and Warranty

Supplied by the manufacturer of your motorhome's chassis (van), the manufacturer's owner's manual (or operating guide) contains important safety, operation, maintenance, and warranty information pertaining to the motorized vehicle portion of your motorhome. Before operating your motorhome, read these instructions carefully and familiarize yourself with the vehicle's operation and safety features.

For your own safety and a longer vehicle life, follow the instructions and warning notices the manufacturer provides in the owner's manual. Disregarding these instructions may result in damage to the vehicle, the environment, or result in personal injury.

Instructions for registering your applicable warranty using the chassis manufacturer's Delayed Warranty Start Form are printed in the TMC Warranty Guide.

Always keep a copy of the manufacturer's owner's manual in your motorhome for reference. Replacement copies are usually available through the van manufacturer's website.

TMC Owner's Packet

Included with your new motorhome is the TMC Owner's Packet. It contains important information pertaining to the safe operation, care, maintenance, and warranties of the factory-installed systems and components of your motorhome. Please read, follow, and retain for reference the information contained in your TMC Owner's Packet.



TMC Owner's Packet

NOTE: A list of component suppliers is available through the Thor Motor Coach Owners Resource Information Service.

Contact TMC Customer Care

Contact your selling dealer or TMC's Customer Care for answers to any question you may have regarding your motorhome, its operation, care, maintenance, service, or TMC warranties, warranty coverage, and warranty service or repairs. TMC Customer Care representatives are available 24 hours a day, 7 days a week at:

Telephone (toll free): **877-855-2867**

Email: wsupport@tmcrv.com

You can also contact TMC's Customer Care by filling out and submitting the on-line form located here:

www.thormotorcoach.com/company/contact-us

1 INTRODUCTION

If you are contacting TMC's Customer Care by email or on-line form, response times are within 1 to 2 business days. You must include your name, phone number, a valid email address, along with your 17-digit Vehicle Identification Number (VIN) and a brief description of your inquiry.

Online Customer Support

A good working knowledge of your motorhome and how to care for it will help you enjoy many years of satisfied motorhome ownership. Specific operational and maintenance instructions for the systems and factory-installed components of your motorhome are not included in this manual, however, more detailed information associated to your motorhome is available on-line through the TMC Owners Resource service:

www.thormotorcoach.com/owners

From the webpage listed above, click on the icons that will direct you to resources such as: TMC Owners Resource, authorized TMC Service Center Locator, TMC Owner's Manuals, and other useful and informative information.

TMC Owners Resource

TMC offers owners access to a complimentary on-line service that provides access to important information pertaining to the operation, maintenance, and care of your motorhome; in greater detail than what is included in this owner's manual.

To access the TMC Owners Resource system, simply click on the OWNERS tab located on the main page of the TMC website (thormotorcoach.com), then click on the Owners Resource icon. You will be directed to a page where you can Sign up, creating a new account or Login to your existing account.



To create a new account, you simply enter your 17-digit Vehicle Identification Number (VIN), enter your contact information and create a user password. This service is available to owners of new and pre-owned TMC motorhomes built since 2010.

The site will give you access to instructional manuals, quick-start guides, and links to instructional videos associated to the factory-installed systems and components unique to your motorhome. Documents are provided in a viewable, printable, and downloadable .pdf format. Filter and search features within the Owner's Resource Document System help you quickly find the reference information you need.

Visit your TMC Owners Resource account often; updates and new information are continually being introduced.

NOTE: Accessing the TMC Owners Resource information can be done with a laptop or desktop computer, tablet, or smartphone. However, whether creating a new account or accessing an existing account, TMC recommends using a computer (laptop or desktop) or tablet for improved performance and ease of document and video viewing.

TMC System Guides

A good source of operational and maintenance information pertaining to TMC motorhomes is available through TMC's System Guides. System Guides are intended to inform TMC motorhome owners about the systems and components installed on their motorhome. System Guides are continuously updated as new features and components are added to the TMC model line-up. System Guides are available as viewable, printable, and downloadable .pdf documents from your TMC Owners Resource account.

NOTE: For owners of Class B motorhomes, Thor offers the Class B Supplement, which has more comprehensive component instructions than those in this owner's manual. Your TMC Owner Resource account has a download link for this useful supplement.

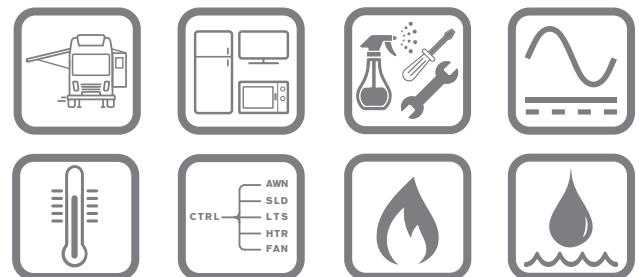

TMC Instructional Videos

TMC provides 'How-To' and other informative videos through the Thor Motor Coach YouTube channel. This video library is constantly being updated and includes helpful information regarding the operation and maintenance of the systems and components installed on your motorhome:

www.youtube.com/user/ThorMotorCoach

For your convenience, instructional videos are also listed and linked from your TMC Owners Resource account.



Link to TMC Owners Resource

Point your QR code reader at the image below to go directly to the TMC Owners Resource Login and Sign-up page.

Click on Sign up and create your personal account and you will have access to an extensive library of information pertaining to the operation, maintenance, and care of your motorhome, in much greater detail than what is included in this owner's manual.



TMC Basic Operation Guides

Operational and maintenance information is also available through TMC's Basic Operation Guides (also referred to as Quick-Start Guides). Viewable and downloadable from your TMC Owner's Resource account, these brief, but informative guides (.pdf format) are a good resource for quick information on a variety of topics, ranging from:

- Basic camp set-up,
- Electrical systems and devices,
- Water systems,
- Appliance operation,
- Jacks and slideouts,
- Towing with your motorhome,
- Care and maintenance,
- Winterizing and storage, and many more.

Filter and search features within the Owner's Resource Document System help you quickly find the reference information you need.

This page is intentionally blank

Section 2: Consumer Information

Dealer's Responsibilities

Your selling dealer is responsible for inspecting both factory and dealer installed components for proper operation. This is referred to as a pre-delivery inspection (PDI).

Your selling dealer is required to provide a thorough and complete walk-through demonstration and perform a test drive with you. The demonstration should provide you with a good understanding of your new motorhome's operation, safety features, and maintenance requirements.

At the time of purchase, your selling dealer should discuss this Owner's Manual, the Owner's Packet, the vehicle manufacturer's owner's manual, and the TMC Warranty Guide, including TMC's Limited Warranties. Their presentation should include assisting you with completing all warranty cards and registrations, and reviewing all component information, including warranty, safety, operation, and maintenance information relating to your new motorhome.

Your selling dealer is required to complete and return the TMC Product Warranty Registration Form (located in the TMC Warranty Guide) to Thor Motor Coach within 15 days of delivery of your motorhome to you. **The Thor Motor Coach Limited Warranty is activated on the date of delivery of the new motorhome to its new owner(s).**

NOTE: Failure to file the Product Warranty Registration Form with TMC will not affect your rights under the applicable TMC limited warranty, as long as you can present proof of purchase and proof of delivery date to TMC, but it can cause delays in obtaining the benefits of the applicable TMC limited warranty, and it may inhibit any servicing facility's ability to provide proper repairs and/or parts replacement.

All agreements between your selling dealer and TMC are for the benefit of the selling dealer and TMC only. Third parties, including retail buyers of motorhomes, are not third beneficiaries of the Agreements, nor may they enforce the terms of the Agreements.

Consumer's Responsibilities

You, as the owner/operator of the motorhome, are responsible for providing regular and proper service and maintenance of your motorhome as outlined in this TMC Owner's Manual, the TMC Warranty Guide, the Owner's Packet, TMC's On-line Customer Support, the vehicle manufacturer's owner's manual, and all individual component suppliers' information. Be sure to have service performed in a timely manner to help

avoid situations possibly caused by neglect or abuse that are not covered under warranty. Thor Motor Coach Limited Warranties do not cover expenses incurred due to routine service and normal maintenance.

If you have questions regarding warranty coverage, contact TMC Customer Care at:

877-855-2867

At the time of purchase:

- Inspect the entire motorhome during the test drive and pre-delivery inspection (PDI) and note any issues in writing on the TMC Product Warranty Registration Form. Ask any questions you may have before leaving the selling dealership.
- Read and indicate your acceptance of TMC's terms and conditions of the Thor Motor Coach Limited Warranty by signing, along with a representative of the dealership, the TMC Product Warranty Registration Form.
- Complete and return all applicable component warranty cards and registrations.
- Familiarize yourself with your new motorhome, its systems, features, and safe operational procedures. Follow all TMC, chassis manufacturer, and all individual component suppliers' instructions regarding safety, operation, and maintenance of their respective products.

Electronic copies of Thor Motor Coach's Owner's Manual and Limited Warranties applicable to your motorhome are available from the Thor Motor Coach website:

www.thormotorcoach.com/owners/owners-manuals

NOTES:

- *Failure to properly maintain your motorhome could result in loss of warranty coverage.*
- *Your motorhome is not designed, nor intended, for permanent housing. Use of your motorhome for long term or permanent occupancy may lead to premature deterioration of its structure, interior finishes, fabrics, carpeting, and/or window treatments, etc.*
- *Damage and/or deterioration due to long term occupancy is not considered normal and may under the terms of the warranty constitute misuse, abuse, or neglect, and therefore void certain warranty protections.*

Change of Address or Ownership

The 'National Traffic and Motor Vehicle Safety Act of 1966' in the United States, and Transport Canada require manufacturers to be able to contact vehicle owners when a correction of a safety-related defect or noncompliance issue becomes necessary.

To enable TMC to contact you, the current owner, with important vehicle product and safety updates, including vehicles with expired warranty coverage, please update your vehicle-related ownership information by contacting TMC by faxing to the attention of Registrations:

574-294-3618

or, by emailing: registrations@tmcrv.com

Include the following:

- Your legal name;
- Your current mailing address (include your prior mailing address for change of address notifications);
- Your telephone number (home and/or cell);
- Your email address;
- Your vehicle's 17-digit vehicle identification number (VIN);
- Your vehicle's TMC serial number;
- Legal proof of purchase (e.g., a legible copy of your bill of sale or insurance card);
- Current motorhome odometer reading.

Vehicle Identification Labels

The vehicle identification number (VIN) and the TMC serial number is listed on a label affixed to the inside of the driver's door jamb of Class B and C motorhomes. For Class A motorhomes, a VIN label is affixed to the inside panel, just left of the driver's seat. Please refer to the chassis manufacturer's owner's manual for the location of the 17-digit chassis VIN tag.

How to Obtain Assistance

Should a question or concern arise regarding your motorhome, the first step is to contact your selling dealer. Their sales, service, and parts professionals will be glad to assist you.

You can also contact a TMC Customer Care representative 24 hours a day, 7 days a week. Telephone (toll free):

877-855-2867

If you leave a voice-message, please include your name, your telephone number, your VIN, and briefly describe the purpose

of your inquiry. You will receive a returned phone call from a TMC Customer Care representative as soon as possible.

Your selling dealer and/or your TMC Customer Care representative should be able to solve any questions or concerns you have regarding your motorhome. However, if their combined efforts are not satisfactory, please send a letter describing the circumstances to:

Thor Motor Coach
Attn: Customer Care
P.O. Box 1486
Elkhart IN 46515 - 1486

Include the following:

- Your selling dealer's name, address, and phone number;
- Your legal name, current mailing address, phone number, and email address;
- Your vehicle's 17-digit vehicle identification number (VIN);
- Your vehicle's TMC serial number;
- Current motorhome odometer reading;
- If applicable, include the individual component supplier's name, part description, model number, and serial number.

Suggestions for Obtaining Service

The following suggestions will help ensure your selling dealer provides the level of service you expect.

Contact your dealer at once:

Service appointments are made based on each dealer's service schedule, so contact your dealer as soon as possible to have service or repairs performed.

Prepare for the appointment:

If warranty-covered work is being performed, have the following documentation available:

- TMC Warranty Guide;
- Applicable component warranties;
- Component serial numbers;
- Vehicle identification number (VIN);
- Vehicle serial number.

All work to be performed may not be covered by the TMC Limited Warranty or component manufacturer's warranties. Discuss warranties and possible service charges with the dealer's service professionals before authorizing service work.

Prepare a list:

Provide your dealer with a written list of specific repairs needed. It is important that you provide the vehicle's repair history to the dealer's service professionals. Keep a maintenance and service log for your vehicle and have it available for your dealer to review.

Be reasonable with your requests:

If you need your motorhome returned by a specific date and time, discuss the situation with the dealer's service professionals and list your repair items in order of priority. This may include making a second appointment for work not completed or a list of parts that the dealer may need to obtain prior to performing service work.

Do not expect access to the service area:

Please do not be offended if you are not allowed in the service area while the service work is being performed. Some insurance requirements forbid admission of customers to service areas.

Inspect the work performed:

Along with the service manager or representative, inspect the service or repair work when you pick up your motorhome. Notify the dealer's service professionals immediately of any dissatisfaction with the performed service work. If you cannot return the vehicle immediately for repairs or corrections, make an appointment as soon as possible.

Please be aware that all service shops require notification of any issues with their repairs within a specified time limit. Make sure you are familiar with the repair facilities policies.

NOTE: Please refer to your TMC Factory Service Appointment Form for important additional information.

Emergency Weekend or After Business Hours Warranty Repair Assistance

In an emergency, if an authorized TMC dealer is not located nearby, please contact your selling dealer for assistance. If your selling dealer is closed, contact TMC Customer Care at:

877-855-2867 (available 24/7)

For warranty pre-repair authorization and for emergency weekend or after-business-hours repair assistance, see How to Obtain Assistance, in this section.

Obtaining Service Repair at Thor Motor Coach

If your motorhome needs service repair, and your dealer recommends that the repairs be made at the TMC Factory Service Center, your motorhome may be returned to TMC with the following guidelines:

- You, the current motorhome owner, or your referring dealer must make a confirmed appointment prior to dropping off your motorhome.
- You are responsible for all transportation costs and hotel accommodations; please be prepared accordingly.
- Unless prior approval has been obtained from the TMC Factory Service Center, all personal items must be removed from the area where you are requesting service repair and the refrigerator emptied. TMC is not responsible for any loss of valuables, stolen property, or loss and/or spoilage of food items.
- Your motorhome holding tanks must be emptied and rinsed. TMC has a dumping station available for customer use.
- The propane system and all electrical systems must be shut down and turned OFF. TMC is not responsible for discharged batteries or loss of propane.
- During the appropriate season, please ensure your motorhome is winterized.
- You must retake possession of your motorhome within 7 business days of TMC notifying you that the repairs have been completed. Otherwise, unless a longer storage time has been previously agreed to, in writing by TMC, you may be liable for additional daily storage fees payable to TMC.

Replacement Parts

Please contact your selling dealer for assistance in obtaining replacement parts and/or accessories. Parts can also be obtained directly from TMC by calling toll free:

877-855-2867, then choose the *Parts Prompt*

Inquiries about obtaining replacement parts can also be emailed to:

parts@tmcv.com

If the original part is no longer available, TMC will make every effort to suggest or provide an appropriate substitute.

Website Usage Disclaimers

Thor Motor Coach (TMC) hereby disclaims and sets forth as follows:

Website Disclaimer of Warranty

The services, information and materials on websites listed in this manual are provided 'AS IS,' and TMC shall have absolutely no liability whatsoever in connection with these website services, information, external links, or third-party links on these websites. Your use of these websites is at your own risk. TMC shall have no liability whatsoever for any errors, omissions, or inaccuracies in the information regardless of how caused or for delays or interruptions in delivery of the information: or any decision made, or action taken or not taken in reliance upon the information furnished.

TMC accepts no responsibility or liability whatsoever with regards to information on these websites, as the information is meant to be of a general nature only and is not intended to address the specific circumstances of any particular individual or entity.

The information provided is not necessarily comprehensive, complete, accurate or up to date; the information is sometimes linked to external sites over which TMC has no control and for which TMC assumes no responsibility: TMC shall have no liability for any loss or injury caused, in whole or in part, by its actions, omissions or negligence, or for any contingencies beyond its control in procuring, compiling or delivering any information. The information is not professional, nor does it comprise legal advice (if you need specific advice, you should always consult a suitably qualified professional).

Disclaimer of Endorsement

Any reference within external or third-party links to any specific commercial products, process or service by trade name, trademark, manufacturer or otherwise, does not constitute or imply it's endorsement, recommendation or favoring by TMC. The appearance of external or third-party links does not constitute endorsement by TMC of the linked websites or the information, products or services contained therein. TMC does not exercise any editorial control over the information you may find at these locations. External or third-party links may be provided for the convenience of the users of that website. TMC is not responsible for the availability or content of these external or third-party sites and does not endorse, warrant, or guarantee any products, services, information, centers, or schools described or offered at these links.

Thor Motor Coach® Recreational Vehicle Privacy Notice

Your Thor Motor Coach RV contains systems which allow Thor Motor Coach to collect information about your recreational vehicle, how it is used, and where it is located, and your Internet connection established through the RV's embedded equipment. Thor Motor Coach may also collect information about you, your RV, and how and where it is used through devices, applications, and services you use in connection with your Connected RV.

Some data, including location information, may be transmitted to Thor Motor Coach (directly or through its service providers) via the included Winegard modem/router whenever that device is connected to the Internet (via wifi, cellular connection, or other means). This data may be transmitted regardless if your RV is parked or in motion.

Thor Motor Coach collects, uses, stores, and/or shares this data for a number of reasons, including providing assistance to you, troubleshooting, improving its products, and to offer you products and services which may be of interest to you. For more information and updates about what information Thor Motor Coach may collect, how we use, store, and share it, and how we protect it, please review the Thor Industries Privacy Policy (www.ThorIndustries.com/privacy-policy/) and the Winegard Company Privacy Policy (www.Winegard.com/about/privacy-policy/).

You may prevent sharing by disconnecting the Winegard modem/router from the electrical power source. Note: if you disable or limit information sharing with Thor Motor Coach or its partners, certain product features may not work or may have limited functionality.

Thor Motor Coach RVs with connectivity features are intended for use in the United States and Canada only. Data and privacy protection laws where you use the RV may impose certain responsibilities on you with respect to your use of RV and related services. You are responsible for ensuring you comply with such laws when you use the RV and related services. You are responsible for informing those you permit to use or occupy your RV (with or without you, and including anyone to whom you loan, give, or sell the Connected RV) how data related to their use of the RV may be collected and processed.

If your Thor Motor Coach RV is equipped with a Sirius Radio receiver, TMC will forward your vehicle and contact information to Sirius. They will use this information to activate your subscription.

Please contact Thor Motor Coach Customer Care at: **877-855-2867** if you have any questions about this privacy notice or our privacy practices.

Chassis Manufacturers Notice

Chassis manufacturers may equip their vehicles with a modem and antenna. This device is used to access important vehicle diagnostic information and may include other useful features. Refer to the manufacturer's owner's manual, or contact a manufacturer's dealership, or visit the manufacturer's website to obtain system information and vehicle privacy policies.

Reporting Safety Defects

In the United States

If you believe that your recreation vehicle has an alleged defect that could cause a crash or cause injury or death, you should immediately inform the National Highway Traffic Safety Administration (NHTSA) and Thor Motor Coach.

If NHTSA receives similar complaints, it may open an investigation, and if it finds that a safety defect exists in a group of vehicles, it may order a recall and remedy campaign. However, NHTSA cannot become involved in individual problems between you, your selling dealer, or Thor Motor Coach.

FOR ADDITIONAL INFORMATION, GO TO THE NHTSA WEBSITE AT:

<https://www.nhtsa.gov/>

TO CONTACT NHTSA BY PHONE:

Call the Vehicle Safety Hotline at: **888-327-4236**
TTY: **800-424-9153**

A NHTSA representative will record your complaint information.

TO CONTACT NHTSA BY MAIL:

Office of Defects Investigations/GRD
NVS-216
1200 New Jersey Ave. SE
Washington, DC 20590

TO CONTACT THOR MOTOR COACH BY PHONE:

Contact TMC Customer Care at: **877-855-2867**

TO CONTACT THOR MOTOR COACH BY MAIL:

Thor Motor Coach
Attn: Customer Care
P.O. Box 1486
Elkhart, IN 46515-1486

In Canada

If you believe your recreation vehicle has an alleged safety defect, you should contact the Department of Transport and Thor Motor Coach to report your safety concerns.

ONLINE:

www.tc.gc.ca/recalls

TELEPHONE:

Toll Free: **800-333-0510** (in Canada)
or: **819-994-3328**
TTY: **888-675-6863**
(Ottawa-Gatineau area or International)

MAILING ADDRESS:

Transport Canada - ASFAD
330 Sparks Street
Ottawa, Ontario
K1A 0N5

TO CONTACT THOR MOTOR COACH BY PHONE:

Contact TMC Customer Care at: **877-855-2867**

TO CONTACT THOR MOTOR COACH BY MAIL:

Thor Motor Coach
Attn: Customer Care
P.O. Box 1486
Elkhart, IN 46515-1486

Langue Française

INTERNET :

<http://www.tc.gc.ca/rappels>

TÉLÉPHONE :

Sans frais : **800-333-0510** (au Canada)
ou : **819-994-3328**
(dans la région de Ottawa-Gatineau et à l'extérieur du pays)

ADRESSE POSTALE :

Transports Canada - ASFAD
330, rue Sparks
Ottawa (Ontario)
K1A 0N5

POUR JOINDRE TMC PAR TÉLÉPHONE :

Appelez l'assistance à la clientèle TMC au :
877-855-2867

POUR JOINDRE TMC PAR COURRIER :

Thor Motor Coach
Attn: Customer Care
P.O. Box 1486
Elkhart, IN 46515-1486

This page is intentionally blank

Section 3: Vehicle Safety

Safety Alerts

Thor Motor Coach uses the following safety symbols and signal words to warn you of possible safety concerns and to provide information to help prevent personal injury and/or damage to the motorhome:

NOTE: Provides important information and useful tips.



This is the safety alert symbol. It is used to alert you to potential personal injury hazards. Obey all safety messages that follow this symbol to avoid possible injury or death. This symbol may be used in conjunction with the following signal words and with a color that corresponds with the associated safety label.

DANGER

Indicates an imminently hazardous situation that, if not avoided, will result in death or severe injury. This alert information is limited to the most extreme situations.

WARNING

Indicates a potentially hazardous situation that, if not avoided, may result in death or severe injury.

CAUTION

Indicates a potentially hazardous situation that, if not avoided, may result in minor or moderate injury. It may also be used to alert against unsafe practices.

NOTICE

Indicates a potential situation that, if not avoided, may result in property damage or damage to your motorhome.

Safety Labels

WARNING

Do not remove manual or labels from RV. If manual is lost or misplaced or labels are damaged or illegible, contact manufacturer or go to manufacturer's website to obtain replacements. Thor Motor Coach's website is: <http://thormotorcoach.com>.

There are safety decals and vehicle information labels affixed throughout your motorhome. Read and follow the instructions listed on all decals, labels, or data plates before and during operation and during storage of your motorhome.

NOTE: Replacement safety labels can be obtained from your selling dealer's parts department or through TMC's Customer Care.

Fire Safety

DANGER

NO SMOKING

All pilot lights, appliances, and their igniters (see operating instructions) shall be turned off before refueling of motor fuel tanks and/or propane containers.

Do not dispense fuel within 20 feet (6.1 meters) of an ignition source.

Can cause ignition of flammable vapors, which can lead to a fire or explosion and result in death or severe injury.

WARNING

Flammable cleaning and maintenance materials should be stored in a nonflammable, vapor-tight container. Do not store flammable clean up rags or materials inside the motorhome, inside any other vehicle, or near any source of flame or ignition. Dispose of all flammable materials in a proper waste disposal facility.

WARNING

DO NOT attempt to use water to put out an electrical or oil-based fire. Water can spread some types of fire, and electrocution is possible with an electrical fire.

3

VEHICLE SAFETY

Awareness and adherence to fire safety procedures is an important part of being a responsible motorhome owner/operator. Make sure that everyone traveling in the motorhome is familiar with the location of exits, including emergency exit egress windows. By following these basic rules of fire prevention, the possibility of a fire can be significantly reduced:

- Never store or transport flammable liquids inside the motorhome.
- Keep cooking surfaces clean of cooking oils and other food spills.
- Never use a flammable liquid or substance as a cleaning agent or solvent.
- Never leave a lit cooktop or cooking food unattended.
- Keep flammable materials away from open flames.
- Never smoke in bed; and when smoking, always use an ashtray.
- Never allow children to play with propane or electrical equipment.
- Never use an open flame as a source of illumination.
- Never leave burning candles, smoking materials, or other open flames unattended.
- Promptly repair faulty or damaged wiring and electrical components.
- Never overload electrical circuits, outlets, or extension cords.
- Locate and repair propane gas leaks immediately.
- Do not allow rubbish and trash to accumulate.
- Spray fabrics annually with a flame retardant.
- Check smoke and LP/CO detectors regularly.
- Check expiration dates on fire extinguishers and detectors and replace on or before expirations.
- Make an emergency escape plan and practice it regularly.
- Make sure doors and windows open easily and stay clear of clutter so that emergency access is not blocked.
- Ensure emergency contact information is up-to-date.
- Never use appliances with frayed or damaged electrical cords or missing ground pins.
- Do not pack travel items closely around electrical devices or heat sources.



Basic Rules of Fire Safety

1. Evacuate everyone (including pets) from the motorhome immediately!
2. After everyone is clear, check the fire to determine if it can be easily put out. **If the fire is too large, or the fire is fuel fed, stay clear of the motorhome and have the fire department manage the emergency.**
3. **If it can be safely done, without risking bodily harm or injury:**
 - › Turn OFF the main propane gas valve at the propane tank;
 - › Switch the 120-volts AC main circuit breaker to the OFF position;
 - › Disconnect the shoreline power cord from the shore power receptacle;
 - › Turn OFF the generator (if equipped);
 - › Disconnect the negative battery cable(s) at the auxiliary battery and chassis battery.
4. DO NOT attempt to use water to put out the fire. Water can spread some types of fire (grease or oil), and electrocution is possible with an electrical fire.
5. Always have faulty or damaged wiring, electrical components, propane tanks, valves, pipes, gas, and electrical appliances inspected by a certified RV repair technician and repaired immediately.

Fire Extinguisher



CAUTION

Always replace the fire extinguisher with a similar Class B-C type.

- **Fire extinguishers must be replaced after any use, even if used briefly.**
- **Fire extinguishers have an effective service life. Replace expired fire extinguishers.**

Fire extinguishers are classified and rated by fire type, A, B, and C. These classifications identify the kinds of fires or burning materials they are designed to extinguish:

- **Class A:** Solid materials such as wood, paper, cloth, rubber, and some plastics.
- **Class B:** Liquids such as grease, cooking oils, gasoline, kerosene, or other flammable liquids.
- **Class C:** Electrical such as electrical wires or other live electrical equipment.



Typical Class B-C fire extinguisher

A dry-chemical fire extinguisher has been installed by the entrance door. It is suitable for extinguishing small fires of the Class B or C type only.

Operation:

For information on how to use your fire extinguisher, refer to the fire extinguisher manufacturer's owner's manual or the label affixed to the side of the fire extinguisher.

Inspection:

Inspect the extinguisher at least once a week (more frequently if it is exposed to weather or possible tampering). This should also be done before beginning a vacation or during an extended trip.

Replacement:

The fire extinguisher must be replaced following the fire extinguisher manufacturer's owner's manual instructions, and/or expiration date listed on the label affixed to the side of the fire extinguisher.

NOTE: Know the location of the fire extinguisher installed in your motorhome and become familiar with its operation.

Smoke Alarm

⚠ WARNING

Test smoke alarm operation after vehicle has been in storage, before each trip, and at least once per week during use.

Failure to do so can result in an undetected faulty smoke alarm, which could lead to death or severe injury.

⚠ WARNING

This smoke alarm may not alert the hearing impaired. Special alarms with flashing strobe lights are recommended for the hearing impaired.

⚠ CAUTION

Ensure the smoke detector and alarm is always kept in good working order. Test this device regularly and immediately replace if it is not functioning properly.

The smoke detector operates on an internal battery. Immediately replace battery when needed and/or on an annual schedule.

The smoke alarm installed in your motorhome is listed for use in recreation vehicles. They only work as intended if they are maintained in operational condition. Smoke alarms have a limited life and over time, will cease to function. Immediately replace the smoke alarm if it is not working properly, if it displays any type of problem, or as recommended by the smoke alarm manufacturer. Be sure to read, understand, and follow the information provided by the smoke alarm manufacturer, including information on the limited life of smoke alarms.



Typical RV smoke alarm

Be aware the smoke alarm is not fool proof and cannot detect fires if smoke does not reach it. Anything preventing smoke from reaching the alarm may delay or prevent an alarm.

Though the alarm horn in this detector meets or exceeds current UL standards, it may not be heard for reasons that include (but not limited to): a closed or partially closed door, distracting noises from electronics, appliances, loud outside noises, etc.

Operation:

The smoke alarm is operational once the battery is correctly installed. It will not function if the battery is missing, disconnected, dead, the wrong type, or not installed correctly. It requires one standard 9-volt battery. Refer to the smoke alarm manufacturer's owner's manual for correct battery and installation information.

The LED light indicates if the battery is functioning properly. When particles of smoke from combustion is sensed, the

3

VEHICLE SAFETY

smoke alarm sounds a loud alarm that continues until the air is cleared of smoke. The LED light also gives a visual indication of a sounding alarm.

When the battery becomes weak, the alarm will 'beep' about once a minute indicating a low battery. This warning should last for 30 days. To assure continued protection, you **MUST** replace the battery once the smoke alarm's low battery warning (beeping) is detected.

Test:

To test the smoke alarm, stand at arm's length from the smoke alarm, as the alarm horn is loud and may be harmful to your hearing. Actuate the test button, which will activate the alarm. Pressing the test button will accurately test all functions. Never use an open flame to test the smoke alarm.

Maintenance:

Vacuum off any dust on the cover of the smoke alarm using a soft brush attachment. Test the smoke alarm after being vacuumed. Never use water, cleaners, or solvents to clean the smoke alarm as these materials may damage the alarm. Do not paint the smoke alarm. Refer to the manufacturer's owner's manual for detailed maintenance information.

Replacement:

Smoke alarms have a limited life and must be replaced following the smoke alarm manufacturer's instructions, and/or the expiration date listed on the device.

Carbon Monoxide (CO)

DANGER

Do not use gas cooking appliances for comfort heating. Can lead to carbon monoxide poisoning, which can cause death or severe injury.

WARNING

The following symptoms are related to carbon monoxide poisoning and should be discussed with all members of the household:

- **Mild Exposure - Slight headache, nausea, vomiting, fatigue; often described as flu-like symptoms.**
- **Medium Exposure - Severe throbbing headaches, drowsiness, confusion, fast heart rate.**
- **Extreme Exposure - Unconsciousness, convulsions, cardio-respiratory failure, death.**

Carbon monoxide (CO) is a poisonous gas that is colorless, odorless, and tasteless. Many cases of reported carbon monoxide poisoning indicate, that while victims are aware they are not feeling well, they become so disoriented they are unable to save themselves by either exiting the vehicle or calling for assistance. Due to their physical size, young children and household pets may be the first to show symptoms of carbon monoxide poisoning.

The risk of carbon monoxide poisoning and/or suffocation exists in any confined space. Do not allow children or pets to play or become entrapped within the storage compartments of your motorhome.

NOTE: Know the symptoms of carbon monoxide poisoning. If you or your passengers experience symptoms of carbon monoxide poisoning, seek immediate medical attention:

- Dizziness
- Vomiting
- Nausea
- Muscular twitching
- Intense headache
- Throbbing in the temples
- Weakness
- Sleepiness
- Inability to think coherently

Exhaust Fumes and Gases

WARNING

Avoid inhaling exhaust gases as they contain carbon monoxide, which is a toxic gas that is colorless and odorless.

A parked motorhome with either the vehicle's engine or the generator running, presents a potential danger of toxic exhaust fumes entering the motorhome.

To avoid breathing exhaust gases, follow these precautions:

- Do not run the engine in confined areas, such as an enclosed garage, any longer than needed to move your motorhome in or out of the area.
- The windows should be closed while driving or running the generator (if equipped) to avoid drawing dangerous exhaust gases into the motorhome.
- If you suspect that exhaust fumes are entering the passenger compartment, have the cause determined and corrected as soon as possible.
- If you must drive under these circumstances, close all the windows and adjust the heating or cooling system

to draw outside air into the motorhome (set the blower on high speed).

- Ensure the motorhome's ventilation system and the carbon monoxide alarm are properly maintained. Keep the ventilation inlet grill(s) clear of snow, leaves, or other obstructions.
- Ensure the motorhome's engine exhaust and the generator's exhaust systems are properly maintained and functional. Repair any damaged exhaust system components immediately.

Propane Safety

DANGER

IF YOU SMELL PROPANE GAS

1. Extinguish any open flames and all smoking materials.
2. Shut off the propane supply on the container valve(s) or propane supply connection.
3. Do not touch or operate electrical switches.
4. Open doors and other ventilating openings.
5. Leave the area until the order clears.
6. Have the propane system checked and leakage source corrected before using again.

Ignition of flammable vapors could lead to a fire or explosion and result in death or severe injury.

DANGER

NEVER TRAVEL WITH, AND/OR STORE PROPANE (LP) CONTAINERS OR CYLINDERS INSIDE YOUR MOTORHOME.

Propane cylinders are designed to vent whenever internal pressures reach a certain threshold. Therefore, the potential of a venting propane cylinder presents a gas leak hazard, which, if ignited, could lead to an EXPLOSION, FIRE, DEATH, OR SERIOUS BODILY INJURY.

DANGER

All pilot lights, appliances, and their igniters (see operating instructions) shall be turned off before refueling of motor fuel tanks and/or propane containers.

Can cause ignition of flammable vapors, which can lead to a fire or explosion and result in death or severe injury.

DANGER

Do not use gas cooking appliances for comfort heating. Can lead to carbon monoxide poisoning, which can cause death or severe injury.

WARNING

Do not fill propane container(s) to more than 80 percent of capacity. A properly filled container contains approximately 80 percent of its volume as liquid propane.

Overfilling the propane container(s) can result in uncontrolled propane flow, which could lead to a fire or explosion and result in death or severe injury.

WARNING

Gas cooking appliances need fresh air for safe operation. Before operating:

- Open vents or windows slightly or turn on exhaust fan prior to using cooking appliance.
- Gas flames consume oxygen, which should be replaced to ensure proper combustion.
- Improper use can result in death or severe injury.

WARNING

THIS PROPANE PIPING SYSTEM IS DESIGNED FOR USE WITH PROPANE ONLY:

- Do not connect natural gas to this system.
- Securely cap inlet when not connected for use.
- After turning on propane, except after normal cylinder replacement, test propane piping and connections to appliances for leakage with soapy water or bubble solution.
- Do not use products that contain ammonia or chlorine to test for leaks. These substances may weaken piping components and cause gas leaks, leading to fire or explosion, which could result in death or severe injury.

Warning labels are affixed throughout your motorhome to provide required information on propane safety. Read and follow the instructions listed, and exercise proper precautions when using propane and propane appliances.

Additional warning labels are located in the cooking area as a reminder that an adequate supply of fresh air for combustion is needed. Unlike a residential home, the oxygen supply in an RV is limited due to its small size. Proper ventilation must be provided when using gas cooking appliances to help avoid the dangers of low oxygen levels and potential asphyxiation.

Thoroughly familiarize yourself with the propane system and its safe operation. Refer to the Propane System section of this manual and always follow the safety and operational instructions provided by the manufacturers of the propane appliances and devices installed in your motorhome.

Combination Carbon Monoxide/Propane Alarm

WARNING

The carbon monoxide/propane (CO/LP) combination alarm installed is intended for use in ordinary indoor locations of recreation vehicles.

Actuation of this alarm indicates the presence of carbon monoxide and/or propane gas, which are colorless and odorless toxic gases. By displacing available breathable oxygen, the presence of these gases has the potential of causing death by suffocation.

Do not disconnect the combination carbon monoxide/propane alarm from its power source.

Individuals with medical problems may consider using warning devices that provide audible and visual signals for carbon monoxide concentrations under 30 PPM.

This alarm will only indicate the presence of carbon monoxide and/or propane gas at the sensor. These toxic gases may be present in other areas of the motorhome.

WARNING

THE CO/LP COMBINATION DETECTOR OPERATES ON 12-volt HOUSE POWER; IT DOES NOT CONTAIN AN INTERNAL BACK-UP BATTERY. IT WILL BE DISABLED WHEN HOUSE BATTERIES ARE DISCONNECTED, OR SHORE POWER IS REMOVED, OR IF THE AUXILIARY BATTERY VOLTAGE DROPS BELOW THE OPERATING THRESHOLD VOLTAGE OF THE DETECTOR!

WARNING

Test the combination carbon monoxide/propane alarm after the motorhome has been in storage, before each trip, and at least once per week during motorhome use.

Failure to do so can result in an undetected faulty CO/LP alarm, which could lead to death or severe injury.

Your motorhome is equipped with a combination carbon monoxide/propane alarm that is listed for use in recreation vehicles. The combination carbon monoxide/propane alarm will only provide its intended protection if it is maintained in operational condition.

Typical combination carbon monoxide/propane alarm



The combination carbon monoxide/propane alarm is wired directly to the motorhome's 12-volt DC electrical system, with continuous power being supplied by the auxiliary battery. There is not a back-up battery in the combination carbon monoxide/propane alarm. If the auxiliary battery cable is disconnected at the battery terminals, the combination carbon monoxide/propane alarm will not be powered, and therefore, will not function.

This alarm is designed to detect the toxic carbon monoxide gas that results from incomplete combustion, such as those emitted from appliances, furnaces, fireplaces, and auto exhaust, along with propane gas that may be present. A carbon monoxide/propane alarm is NOT A SUBSTITUTE for other combustible gas, fire, or smoke detection alarms.

Although this alarm is designed to sense the presence of carbon monoxide/propane gas, there are other combustible fumes or vapors that may be detected by the sensor including, but not limited to: acetone, alcohol, butane, and gasoline.

Please note that there are hazards against which carbon monoxide detection may not be effective, such as detection of natural gas and other harmful substances.

These chemicals can be found in commonly used items such as deodorants, colognes, perfumes, adhesives, lacquer, kerosene, glues, wine, liquor, most cleaning agents, and the propellants of aerosol cans. Be sure to read, understand, and follow the owner's information from the manufacturer of the combination carbon monoxide/propane alarm. This includes information regarding the limited service-life of the alarm.



What to do if the alarm sounds:

1. Operate the RESET/SILENCE button.
2. Call emergency services (911 in the United States or a local fire department).
3. Immediately move to fresh air (outdoors, or by an open door or window).
4. Do not re-enter the motorhome or move away from the open door or window until the emergency service

responders have arrived, the motorhome has been aired out, and the alarm remains in its normal (OFF) condition.

If the alarm reactivates within a 24-hour period, repeat steps 1-4, and call a qualified appliance technician to investigate for sources of carbon monoxide and inspect for proper operation of this equipment. Make sure that motorized vehicle(s) and equipment are not and have not been operating adjacent to the motorhome.

Correct all identified problems immediately. Note equipment not inspected by the technician and consult the manufacturer's instructions or contact the manufacturer directly for more information about carbon monoxide safety and this alarm.

Test:

The Test switch is located on the front of the alarm. Pressing the switch should activate the alarm horn. If the alarm fails to sound, refer to your Owner's Packet for information provided by the manufacturer of the combination carbon monoxide/propane alarm.

Maintenance:

Vacuum the alarm cover at least once a year. Clean the cover by hand using a cloth dampened in clean water. Dry with a soft cloth. Do not spray the front panel of the alarm with cleaning agents or waxes. Doing so could damage the sensor causing an alarm or cause the alarm to malfunction. Do not paint the face of the alarm.

Replacement:

The combination carbon monoxide/propane alarm has a limited service-life and must be replaced following the alarm manufacturer's instructions and/or the expiration date listed on the device.

Fuel System Safety

DANGER

NO SMOKING

All pilot lights, appliances, and their igniters (see operating instructions) must be turned off before refueling of motor fuel tanks and/or propane containers.

Do not dispense fuel within 20 feet (6.1 meters) of an ignition source.

Can cause ignition of flammable vapors, which can lead to a fire or explosion and result in death or severe injury.

NOTICE

Depending upon model and chassis, TMC Class B Motorhomes may be equipped with either gasoline or diesel-fueled engines. Always be sure to fuel your motorhome with the correct petroleum products.

Be extremely careful when fueling your motorhome. Always shut OFF the engine, do not smoke, do not use cellular phones, and shut OFF all pilot lights before adding fuel. Fuel spills represent a serious fire hazard and should be cleaned up immediately. Never restart the engine or relight pilot lights while fuel vapor is present.

In cold weather conditions or when your motorhome has not been used for a while, a fuel additive (customer supplied) may be needed. Refer to the chassis manufacturer's recommendations for fuel additives.

Emergency Exit

WARNING

IN AN EMERGENCY, PULL THE LATCH TWICE TO UNLOCK THE DOOR (RAM ProMaster side door).

In case of an emergency, a locked side and rear door latch can be manually unlocked and opened from the inside of the vehicle. For ProMaster Vans, the occupant must pull on the inside door handle twice, first unlocking the latch, then un-latching the catch mechanism. Then slide (side) or push (rear) the door open. Other van models may require pulling up or sliding a locking device to manually unlock the door. Refer to the van manufacturer's owner's manual for door locking and unlocking instructions.

IMPORTANT: Van manufacturers may include a child safety device on sliding side doors. When activated, this device prevents the door from being opened from the inside. To ensure an emergency exit pathway via the side door, deactivate this device when parked.

Front Airbags

⚠️ WARNING

Your motorhome may be equipped with an airbag restraint system. Follow all airbag instructions provided by the chassis manufacturer including all warnings regarding the placement and safety of child and infant passengers.

Failure to do so can result in severe injury or death.

If the vehicle is equipped with front passenger airbags, ensure that the airbag system is appropriately set for the size and weight of the front passenger. Refer to the chassis manufacturer's owner's manual for front airbag operation.

Driver and Front Passenger Seats

⚠️ WARNING

All swivel seats located in the cab of the vehicle (driver and front passenger) must be in the locked, upright and forward-facing position while the vehicle is in motion and seats are occupied.

Driver, front passenger, and all occupants must always wear seat belts while the vehicle is in motion.

Failure to do so can result in severe injury or death.

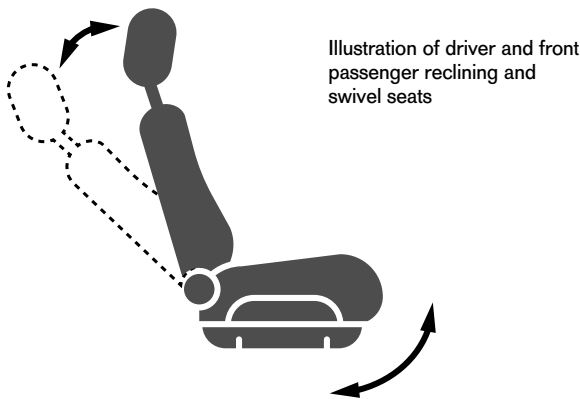

For comfort and convenience, your motorhome may be equipped with tilt and swivel seats in the cockpit area. These features are designed to **only be used when the motorhome is parked**. Before travel or moving the motorhome, ensure all front seat backs are returned to an up-right position, swiveled, and locked in their forward-facing position.

Some TMC motorhomes include tilt and swivel seating in the coach area. If these seats are equipped with seatbelts and intended for passenger occupation while the vehicle is in motion, then these seats must also be returned to an up-right and swivel-locked position before travel.

Seatbelts

⚠️ WARNING

- All occupants in this vehicle must be seated at a designated seating position and must wear seatbelts at all times while this vehicle is in motion.
- All swivel and/or reclining seats must be returned to their upright, forward-facing, and locked position while the vehicle is in motion.
- Seatbelts are designed for single occupancy. Do not use a seat belt for more than one person at a time.
- The sleeping accommodations in this vehicle are designed for occupancy only while vehicle is NOT in motion. Do not occupy beds or any other seats that are not equipped with seatbelts while the motorhome is in motion.
- Seatbelts installed in areas that convert to beds or bunks may fall between cushions or framework. Be sure beds are in their upright seating position and all seatbelts are properly and securely placed and available for use before travel.

Failure to do so can result in severe injury or death.

⚠️ WARNING

Failure to inspect and if necessary, replace damaged seatbelts could result in severe personal injuries in the event of a collision.

If seat belt replacement is necessary, ensure mounting and fastening devices are torqued to manufacturer's specifications.

All occupants must be furnished with and use seatbelts while the motorhome is in motion. Additionally, the sleeping accommodations in your motorhome are designed for occupancy only while the vehicle is parked. Never allow passengers to lie down while the motorhome is in motion. They would not be properly restrained in the event of a traffic accident or sudden vehicular movement, such as a collision or swerving to avoid a road hazard.

Operation:

Driver and front passenger seats must be locked in a forward-facing position with seatbelts fastened while the motorhome is in motion. Avoid seat rotation while in transit.

- Insert the belt tongue into the proper buckle (usually the buckle closest to the belt tongue) until you hear a snap and feel it latch. Make sure the tongue is securely fastened in the buckle.



Typical passenger seatbelts located in a dinette or sofa seating area

- Adjust the belt to the proper position and tension; snug and as low as possible around the hips, not around the waist.
- To unfasten, push the release button and remove the tongue from the buckle.

Inspection and Replacement:

Inspect the seatbelts in your motorhome periodically to ensure they work properly and are not damaged. Make sure there are no nicks, tears, or cuts in the belt material. Replace the motorhome seatbelts as necessary. A qualified service technician should inspect all seat belt assemblies after a collision. TMC recommends that all seat belt assemblies installed in vehicles involved in a collision be replaced.

Child Passenger Safety

⚠ DANGER

Never allow a passenger to hold a child on his or her lap while the motorhome is moving. You are required by law to use safety restraints for children in the United States and Canada.

If small children, generally children who are four years old or younger and weigh 40 lbs. (18 kg. or less), ride in the motorhome, they must be put in properly installed safety seats made especially for children.

Rear-facing child seats or infant carriers should never be installed and used in the front seats of the motorhome.

⚠ WARNING

- **Improper installation or failure to properly secure a child restraint can lead to failure of the restraint. The child could be severely injured or killed.**
- **Follow the child restraint manufacturer's directions exactly when installing an infant or child restraint.**

⚠ WARNING

- **Never place a rear-facing child restraint in front of an airbag. A deploying passenger front airbag can cause death or severe injury to a child 12 years or younger, including a child in a rear-facing child restraint.**
- **Never install a child safety restraint in the front seat of a vehicle. Only use child safety restraints in the rear seats. If the vehicle does not have a rear seat that includes a safety restraint belt or anchor that enables securing a child safety seat, do not transport children requiring child safety restraints in that vehicle.**
- **To ensure proper safety belt fit, always use booster seats for children who are size and age appropriate. Check the vehicle (van) manufacturer's safety information or governmental safety regulations for child sizing charts.**
- **Always follow the vehicle manufacturer's safety instructions, along with state and federal regulations regarding the transporting children and small adults.**

⚠ WARNING

Never leave a child or pet unattended in a parked vehicle. On hot days, the temperature inside the vehicle can rise very quickly. Exposure of people or animals to these high temperatures for even a short time can cause death or serious heat related injuries, including brain damage. Small children are particularly at risk.

A child or animal left in a parked car could inadvertently operate equipment or features that could cause entrapment, cause the vehicle to move, or otherwise cause an unsafe condition.

When transporting a child that requires the use of a child safety restraint system (seat), TMC recommends installing the child safety seat in the forward-facing booth dinette position. If the motorhome is not equipped with a forward-facing booth dinette seat equipped with seatbelts and a child safety seat anchor, small children that require a child safety seat should not be transported in the motorhome.

Always follow the instructions and warnings that are included with any infant or child safety restraint system:

- If the child is the proper size, restrain the child in a safety seat. Children who are too large for child safety seats (as specified by your child safety seat manufacturer) should always wear seatbelts.
- If the shoulder belt portion of a combination lap and shoulder belt can be positioned so it does not cross or rest in front of the child's face or neck, the child should wear the lap and shoulder belt.

3

VEHICLE SAFETY

- Never use pillows, books, or other objects to boost a child, passenger, or pet.
- Refer to the vehicle (van) manufacturer's owner's manual for additional occupant safety information.

NOTE: Check with your local and state or provincial laws for specific requirements regarding the safe transport of children in your motorhome.

For additional information, refer to:

<http://www.nhtsa.gov/parents-and-caregivers>

or call 1-888-327-4236.

In Canada, refer to Transport Canada's website:

<https://tc.canada.ca/en/road-transportation/child-car-seat-safety>

Transporting Pets

WARNING

Unsecured and unrestrained animals can interfere with safe vehicle operation and may be thrown around in the vehicle in the event of an accident or sudden steering and braking maneuvers, injuring vehicle occupants and pets in the process.

- **Never leave a pet unattended in a parked vehicle. On hot days, the temperature inside the vehicle can rise very quickly. Exposure of animals to these high temperatures for even a short time can cause death or serious heat related injuries.**
- **Always secure animals while the vehicle is in motion, using a suitable and secured animal harness or carrier.**

Airbags deploying in the front seat could harm your pet. An unrestrained pet will be thrown about and possibly become injured or injure a passenger during panic braking or in a collision.

Pets should be restrained in the rear seat (if equipped) in pet harnesses or pet carriers that are secured by seatbelts or other anchoring devices.

Refer to the chassis manufacturer's owner's manual for additional and important information regarding occupant and pet safety.

Mirrors and Vision Systems

For safe driving and vehicle maneuvering, both on and off the highway, it is imperative that the motorhome driver/operator becomes proficient with using mirrors and vision systems. Vision aids for motorhomes vary, due in part to the variety of motorhome classes and sizes. Optional equipment and driver preferences are also factors that determine the type of vision aids equipped on motorhomes.

Mirrors

The mirrors on your motorhome should always be kept in adjustment and good working order. Always check mirror adjustment before moving the motorhome to ensure an unobstructed rearward view.

Vision Systems

Your TMC motorhome may be equipped with a rear and/or side vision system. If equipped, the installation includes a rear-view camera mounted along the top of the motorhome's rear valance and an in-dash camera monitor, usually integrated with the dash radio screen or interior rear-view mirror. Some installations may also include side-view cameras. Camera signals are fed to the dash radio/camera monitor and appear when the gear selector is placed in reverse, or with side-view cameras, actuated by the turn signals.

To operate:

1. For the camera monitor to function, the dash radio must be ON. It is powered by the auxiliary battery(ies), therefore, the master battery switch must also be ON. It is normal to keep the master battery switch in the ON position while traveling. Doing so also allows the vehicle's charging system to charge the auxiliary battery(ies) while the engine is running.
2. When the gear selector is placed in REVERSE, the radio display automatically changes to the rear-view camera monitor, allowing for a rearward view via the camera and monitor system.



Typical Rear-view Camera

- When the gear selector is moved out of REVERSE, the camera will automatically turn off and the radio display will revert to the previous screen.

NOTE: In most motorhome installations, the dash radio is powered by the auxiliary (coach) battery(ies). When the back-up camera monitor is integrated into the dash radio display, the Main Battery Switch must be ON in order to activate the back-up camera system.

Your motorhome may be equipped with a dash radio and vision system supplied by the chassis (van) manufacturer. Refer to the chassis manufacturer's owner's manual for radio and vision system operations.

Laws of the Road

It is advisable to contact the Department of Motor Vehicles in each state or country in which you travel, for up-to-date information regarding operation and licensing requirements for your motorhome and its drivers/operators.

Clearance and Side Marker Lights

For vehicle safety and visibility on the highway, clearance and side marker lights are installed on your motorhome. The location and color of marker lights are regulated by Federal law and must comply with all applicable requirements prescribed for it by FMVSS/CMVSS 108. Please maintain your motorhome's clearance and side marker lights as described in this reference:

<https://one.nhtsa.gov/cars/rules/standards/conspicuity/TBMpstr.html>

Emergency Stopping

If an emergency requires you to be stopped along the highway, follow these guidelines:

- Pull off the road as far as possible.
- Put the motorhome's transmission in the PARK position and apply the PARKING BRAKE.
- Turn ON the hazard warning flashers.
- Use three red warning indicators such as flares, reflectors, or lanterns as required by the Uniform Vehicle Code and Model Traffic Ordinance as follows:
 - Place the first warning indicator on the traffic side of the motorhome, directed toward traffic ap-

proaching the rear of the motorhome, approximately 10 feet from the rear bumper.

- Place the second warning indicator 100 feet behind the motorhome, in the center of the lane or shoulder occupied by the motorhome, and directed toward traffic approaching the rear of the motorhome.
- Place the third warning indicator 100 feet in front of the motorhome, in the center of the lane or shoulder occupied by the motorhome, and directed towards the traffic approaching the front of the motorhome.
- If stopped within 500 feet of a curve, crest of a hill, or other obstruction to view, place a warning indicator in the direction of the obstruction (front and/or back of the motorhome), at a distance of 100 feet to 500 feet from the stopped motorhome so as to afford ample warning to traffic approaching the motorhome.

- Always stand off the road, out and away from of the lanes of traffic.

NOTE: Curves and/or hills may affect the safe placement of warning indicators, such as safety reflectors, cones, flares, etc. Extinguish flares before leaving the emergency parking site.

Along with other emergency equipment (reflectors, first-aid kit, etc.), it is good safety practice to carry a reflective safety vest and wear it anytime you are stopped or parked along a road or highway.

Reference: Emergency signals, stopped commercial motor vehicles; Code of Federal Regulations: Title 49, Subtitle B, Chapter III, Subchapter B, Part 392, Subpart C, §392.22.

Chassis Manufacturer's Vehicle Safety Features

The manufacturer of the vehicular portion of your TMC Class B motorhome (Ford, Mercedes-Benz, Fiat-Chrysler) may have incorporated safety and driver-assist features into your vehicle.

Varying with brand and model, safety features may include: Adaptive Cruise Control, Attention Assist, Traffic Sign Assist, Active Lane keeping Assist, Blind Spot Assist, Forward Collision Warning with Active Braking, and more.

Review the vehicle manufacturer's owner's manual and other sources of information from the manufacturer to fully utilize the safety and driver-assist features of your new Class B motorhome.

Safely Driving the Motorhome

- Always operate the motorhome at a safe speed, which in some conditions may be less than the posted speed limit.
- All passengers must wear safety belts.
 - a. Passengers can dramatically reduce their risk of being killed or seriously injured in a crash by wearing their safety belts.
 - b. Drivers should be responsible for ensuring all passengers are properly using safety belts.
 - c. Never transport more passengers than there are available safety belts installed in the motorhome.
 - d. Ensure infants and children are properly secured in age-and-weight-appropriate safety restraints.
 - e. Secure pets in harnesses or other appropriate safety restraints.
- Drivers must be well-rested, alert and maintain a safe speed for weather and road conditions.
- Drivers should keep their eyes on the road and hands on the steering wheel.
- Drivers should not allow themselves to become distracted while operating the motorhome. If something other than operating the vehicle requires driver attention, safely pull off to the side of the road and attend to the situation.
- Drivers must be especially cautious on curved roads and maintain a safe speed to avoid running off the road or losing control of the motorhome.
- If the vehicle's wheels proceed off of the roadway, gradually reduce speed and steer back onto the roadway when it is safe to do so. Avoid abrupt maneuvers to return the vehicle to the roadway.
- Your vehicle may be equipped with advanced driver assist technologies. Remember that even advanced technology cannot overcome the laws of physics. It's always possible to lose control of a vehicle due to inappropriate driver input for the conditions.
- In the event of a flat tire or tread separation, gradually slow down the vehicle, steer to the side of the road while avoiding abrupt maneuvers.
- Motorhomes are substantially longer, wider, taller, and heavier than cars, they;
 - a. Require more space and additional reliance on the side-view mirrors for changing lanes, turning corners, and making parking maneuvers;
 - b. Require additional braking time and distance;
 - c. Do not respond as quickly to abrupt steering inputs;
 - d. Are affected by strong winds, which in some conditions, can make driving the motorhome difficult;
 - e. Have a higher center-of-gravity, which affects the vehicle's handling characteristics.
- Ensure all drivers and co-drivers are practiced with the unique driving and handling characteristics of the motorhome.
- Backing the vehicle can present unique challenges and hazards. Use mirrors, back-up cameras and when necessary, a spotter (person outside the motorhome giving directions to the driver) to ensure safe vehicle movement.
- Do not exceed the vehicle weight limits or axle weight limits specified on the Federal Weight Label (Section 5). Exceeding any vehicle weight rating could result in serious damage to the vehicle, loss of vehicle control, and increases the risk of vehicle rollover and personal injury.
- Towing trailers beyond the maximum recommended gross towing capacity of this vehicle and its towing hitch could result in a loss of vehicle control, vehicle rollover, and personal injury. Refer to Section 5 of this manual and the chassis manufacturer's owner's manual for important towing information.
- Check that you have up-to-date and correct paperwork such as an owner's registration card, vehicle registration, proof of insurance, valid driver's license, etc.

Chemical Sensitivity

WARNING

Operating, servicing, and maintaining a passenger vehicle or off-road vehicle can expose you to chemicals including engine exhaust, carbon monoxide, phthalates, and lead, which are known to the State of California to cause cancer and birth defects or other reproductive harm. To minimize exposure, avoid breathing exhaust, do not idle the engine except as necessary, service your vehicle in a well-ventilated area and wear gloves or wash your hands frequently when servicing your vehicle.

For more information go to: www.P65Warnings.ca.gov/passenger-vehicle

When your new motorhome, and for some time afterward, has been closed-up for an extended time-period, you may notice a strong odor associated with chemical off-gassing (or out-gassing). This is not a defect in your motorhome. There are many materials and products used in the construction of recreational vehicles, such as carpet, linoleum, plywood, insulation, paint, and upholstery, that when new or when exposed to elevated temperatures and/or humidity, may off-gas chemicals, including formaldehyde. Off-gassing may cause irritation of the eyes, nose, and throat and sometimes headache, nausea, and a variety of asthma-like symptoms. Elderly people and young children, as well as anyone with a history of asthma, allergies, or lung problems, may be more susceptible to the effects of off-gassing.

NOTE: Chemical off-gassing is not a defect in your motorhome and is not covered by Thor Motor Coach's Limited Warranties.

Ventilation

To reduce exposure to chemicals from off-gassing, it is of utmost importance that you ventilate your motorhome. Chemical off-gassing is accelerated by heat and humidity; therefore, ventilation should occur frequently after purchase and at times when the temperatures and humidity are elevated. Keeping the motorhome tightly closed has the potential of increasing the formaldehyde level of the interior air. Ventilate the motorhome by opening windows, exhaust vents, and doors. Operating ceiling fans and vents, air-conditioners, and the furnace will help dry the air. Also follow the recommendations regarding how to avoid condensation problems contained in Section 12. Many of the recommendations listed there will assist in avoiding exposure to off-gassed chemicals.

NOTE: For additional information about ventilation and chemical sensitivity, refer to TMC's Care and Maintenance System Guide, available through your on-line Owners Resource account.

Smoking and Medical Advice

TMC recommends that you do not smoke inside your motorhome. In addition to causing damage to your motorhome, tobacco smoke releases formaldehyde and other toxic chemicals.

If you have any questions regarding chemical sensitivity, consult with your physician or local health services provider.

Formaldehyde

Most of the concern regarding chemical off-gassing pertains to the chemical, formaldehyde. Formaldehyde is a naturally occurring substance and is also a key industrial chemical used in the manufacture of the numerous materials and products used in the construction of recreational vehicles. Trace levels of formaldehyde are also released from smoking, cooking, use of soaps and detergents, such as carpet shampoos, cosmetics, and many other household items. Some people are very sensitive to formaldehyde, while others may not have a reaction to the same level of chemical exposure. For the materials used in the construction of your motorhome, the amount of off-gassed formaldehyde decreases over time.

California 93120 Phase 2 Formaldehyde Compliance

Your motorhome may be compliant to California Formaldehyde Phase 2 Codes. If so, it will be labeled with a compliance identification tag similar to this illustration. If you have questions or concerns regarding formaldehyde and your motorhome, please contact Thor Motor Coach Customer Care:

877-855-2867

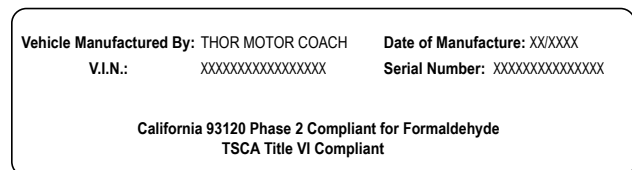

Typical California Formaldehyde Compliance label

This page is intentionally blank

Tire Safety

⚠ DANGER

Failure to follow proper inflation guidelines may result in tire failure, which under certain circumstances, can cause loss of vehicle control or accidents that may result in property damage, bodily injury, and/or death.

⚠ WARNING

Check tire pressure at the beginning of each trip and frequently throughout the trip to obtain the maximum performance and life from the tires. Follow the instructions listed on the Federal Certification label, located inside your motorhome, to determine the correct tire pressures for your vehicle.

Read and follow the safety instructions listed below before traveling in your motorhome:

- Proper care and maintenance of your motorhome's tires is essential to the safe operation of your motorhome.
- You must follow the tire inflation guidelines, listed on the Federal Weight Label, for correct tire inflation and maximum load capacity (see Section 5).
- Under-inflation of tires is just as dangerous as over-inflation.
- To ensure your motorhome tires are operating at their peak performance and safety, regular inspection of tires and checking tire pressures is absolutely mandatory.
- Wheel alignment, wheel balance, tire inflation, improper loading, and worn bearings will affect tire wear. Examine your motorhome tires frequently and inspect for cracking, bulging, uneven tread wear, and other tire-related issues.

When traveling in your motorhome, check the inflation pressure of each tire at least weekly to insure maximum tire performance, and travel wear. Tire pressure should only be checked when the tires are cold. During travel, your tires heat up and the air pressure inside the tire increases.

NOTE: NHTSA's tire rating listings are located on-line at: <https://www.nhtsa.gov/equipment/tires>

Tire Inflation and Inspection

Tires and wheels support the entire weight of this motorhome and its contents. The tires are also the only contact the motorhome has with the road surface. Determining and maintaining proper tire inflation and weight (load) restrictions are the most important factors in maximizing the life of motorhome tires.



Tire pressure under and/or over inflation can cause severe tire failure

Driving on a tire that does not have the correct inflation pressure for the vehicle load is dangerous and may cause premature wear, tire damage, tread de-lamination and/or loss of control of your motorhome. Avoid premature tire damage by keeping tires properly inflated.

Find your PSI:

PSI (pounds force per square inch) is a measure of air pressure used to correctly inflate your tires. The correct PSI listing for your tires is located on your motorhome's Federal Weight Label (see Section 5). KPa (kilopascals) is another commonly used air pressure measurement:

$$1 \text{ PSI} = 6.894 \text{ kPa}$$

Checking Tire Pressures

Check all tire pressures (including the spare tire) before and after a trip and at least weekly while traveling, using an accurate pressure gauge. Always check inflation pressures when the tires are cold. Correct tire inflation cannot be determined by visual inspection only.

Your vehicle may include a Tire Pressure Monitoring System (TPMS), but this is NOT a substitute for manually checking tire pressure. See the chassis manufacturer's owner's manual for additional information.

4

TIRES AND WHEELS

Tire Inflation Quick Tips:

Always check your tires' inflation pressure before and after trips, and at least once a month while storing your RV.

- Remember to let your RV tires cool before taking a tire pressure reading.
- Have all luggage, equipment, fluids (fuel, water, gas, etc.) and accessories in your RV before weighing to determine the total gross vehicle weight.
- Never exceed the vehicle load capacity found in the RV owner's manual or the maximum load molded on the tire sidewall.
- Make sure to check the inflation pressure of outer and inner tires to ensure even load distribution.
- Adjust the inflation pressure on all tires to match the tire that is carrying the heaviest load.
- All tires on the same axle should have the same inflation pressure to support the heaviest load.

Inspect the Condition of Your Tires







It's important to check every tire on your RV on a regular basis. Rotate the tires completely and make sure there are no nails or other objects penetrating any of the tires. If you find something, do not drive the RV until you have your tires inspected by an authorized Goodyear® Commercial Tire Dealer. Immediately replace any tires if necessary.

Tire Inspection Tips:

- Check every tire for signs of sidewall cracking.
- Avoid using sidewall treatments or dressings, which can actually accelerate cracking.
- Look for worn tires that can decrease traction, reduce handling and are more susceptible to punctures.
- Replace tires before they reach the tread depth indicator.
- You can find tread depth indicators between the tread grooves at locations marked on the sidewall with little triangles.

Reference: Goodyear Tire and Rubber Company: Publication 00-00-46437-11/14

Common Tire Wear Patterns

IF YOUR FRONT TIRES LOOK LIKE THIS:						
TIRE PATTERN	TOE	CAMBER	CENTER	EDGE	CUPPING	PATCHY
COMMON CAUSE	VEHICLE WHEEL ALIGNMENT	VEHICLE WHEEL ALIGNMENT	TIRE OVER INFLATION	TIRE UNDER INFLATION	VEHICLE WORN SUSPENSION	TIRE OUT OF BALANCE

NOTE: The use of tire traction devices (studded tires or snow chains) may either be prohibited or required in certain travel regions and/or weather conditions. Always

check with the state's Department of Transportation for vehicle operating regulations and guidelines.

Lug Nut Torque

CAUTION

As part of your pre-travel checklist, always check lug nut torque with a properly calibrated torque wrench. Torque lug nuts to the vehicle manufacturer's specifications.

Always properly torque lug nuts as part of a tire changing procedure.

Ensuring wheel mounting nuts (lug nuts) on the wheels are tight and properly torqued is a vitally important responsibility for safe motorhome travel. Inadequate and/or inappropriate wheel nut torque (tightness) is a major reason that lug nuts loosen or fail in service. Loose lug nuts can rapidly lead to a wheel separation with potentially serious safety consequences.

Refer to the chassis manufacturer's information for proper lug-nut torque and tightening sequence.

Changing a Damaged Tire

CAUTION

Always follow the vehicle manufacturer's instructions and procedures for jacking and securing the motorhome when tire changing is necessary.

If you experience a flat tire while driving your motorhome:

- Gradually decrease your vehicle speed, braking lightly if possible.
- Hold the steering wheel firmly, direct the motorhome to a safe place along the side of the road.
- Once safely parked, place warning markers as described in Section 3, Emergency Stopping.
- If you need assistance, contact a road service provider, a qualified RV or tire service repair center, or if an emergency, call 911 (in the U.S.) for assistance.
- Make sure the road service technician reads and is familiar with the tire changing information provided by the chassis manufacturer. Make sure the wheel nuts have been tightened to the proper torque as outlined in the chassis manufacturer's owner's manual.

NOTE: There are factory-installed components attached to the undercarriage of your motorhome. Be sure jacks and jacking devices do not contact and damage undercarriage components.

Wheel Alignment

NOTICE

The front suspension and steering system of this motorhome was factory aligned prior to it being dispatched to the dealership. The alignment is however, greatly affected by the way the unit is loaded prior to travel. This loading includes how much cargo, water, and LP are carried as well as the distribution of said cargo. Thor Motor Coach advises to have the alignment checked in the fully loaded condition (the way you would normally load the unit to travel). Not having the alignment checked and reset can result in abnormal tire wear.

It is very important to maintain proper wheel alignment for your motorhome. Improper wheel alignment not only contributes to premature tire wear, but also severely affects vehicle handling. Keeping your motorhome's front wheels in alignment is part of a normal maintenance routine. Please follow the recommendations listed in the notice above and on the corresponding label affixed to your motorhome.

Toe-in and toe-out (only) are inspected by TMC prior to shipment to your selling dealer.

Tire Replacement

WARNING

Failure to replace damaged tires with tires of the same size, type, traction, and load rating than the originally equipped tires can significantly affect the weight carrying capacity, handling, and safety of your motorhome.

WARNING

Ensure the spare tire is the same size and specifications listed on your motorhomes Federal Weight Label.

Tires degrade over time depending on conditions they are subjected to throughout their service life, such as weather, storage, and conditions of use (load, speed, inflation pressure, etc.). In general, tires should be replaced after six years regardless of tread wear. Heat caused by hot climates or frequent high-loading conditions, however, can accelerate the aging process and may require you to replace the tires more frequently.

You should also replace your spare tire when you replace the road tires or after six years due to aging, even if has never been used.

4

TIRES AND WHEELS

Replacement tires should be exchanged with the same size, type, load rating, traction, and temperature rating of the original equipped tires. Tire specifications are listed on the motorhome's Federal Weight Label or found within the chassis manufacturer's owner's manual.

NOTE: Installing replacement tires with a higher limit than that of the originals does not increase the payload capacity of the motorhome. Refer to the chassis manufacturer's owner's manual for additional information.

Tire Identification Information

To maintain the load capacity of your motorhome, it is vitally important to only replace worn or damaged tires with tires with ratings equal to or higher than what was originally equipped on your vehicle.

The illustration below describes important tire information that is embossed on every tire by the manufacturer.

NOTE: NHTSA's tire rating listings are located on-line at: <https://www.nhtsa.gov/equipment/tires>

R: The "R" stands for radial. Radial tires have been the industry standard for the past 20 years.

P or LT: The "P" indicates the tire is for passenger vehicles. "LT" indicates the tire is for light trucks.

NOMINAL WIDTH: This three-digit number gives the width of the tire in millimeters from sidewall edge to sidewall edge. The larger the number, the wider the tire.

MAXIMUM LOAD RATING: This number indicates the maximum load the tire can carry.

MAXIMUM PERMISSIBLE INFLATION PRESSURE: This number is the greatest amount of air pressure that should ever be put in the tire. This is NOT the same as the vehicle manufacturer's recommended tire pressure.

TEMPERATURE: The temperature rating indicates how well the tire resists heat.

ASPECT RATIO: This two-digit number gives the tire's ratio of height to width. A number of 50 or lower indicates a short sidewall for improved steering response and better overall handling.

TRACTION: The traction rating indicates the tire's ability to allow a car to stop on wet pavement in a shorter distance.

TREADWEAR: The treadwear rating indicates how long the tire should last. The higher the number, the longer it should take for the tires to wear down.

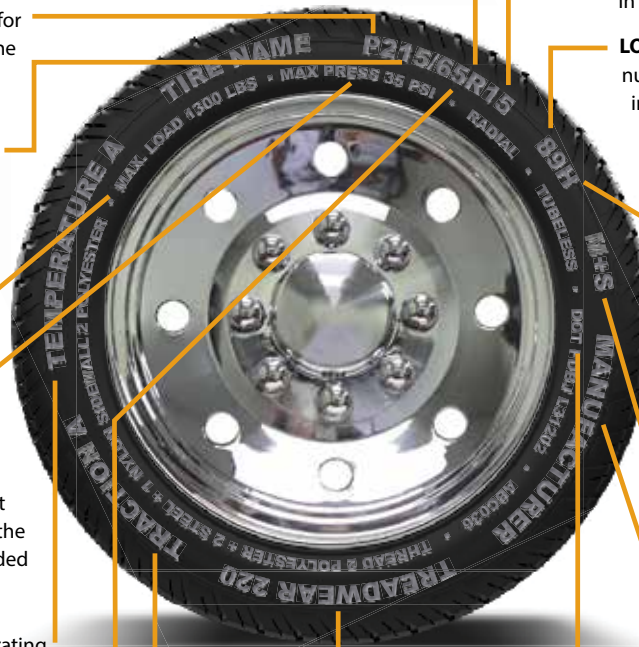

RIM DIAMETER CODE: This two-digit number is the wheel or rim diameter in inches.

LOAD INDEX: This two- or three-digit number is the tire's load index. It is an indicator of how much weight each tire can support. Note: you may not find this information on all tires because it is not required by law.

SPEED RATING: The speed rating tells you the maximum speed capability of a tire. The speed ratings include speeds from 99 mph to above 186 mph. Note: you may not find this information on all tires because it is not required by law.

M+S: This indicates that the tire has some mud and snow capability.

MANUFACTURER: The name of the tire manufacturer.

U.S. DOT TIRE IDENTIFICATION NUMBER:

This number begins with the letters 'DOT' and indicates that the tire meets all Federal standards. The next two or three numbers or letters are the plant code where the tire was manufactured. The last four numbers represent the week and year the tire was built. For example, the numbers 3107 means the 31st week of the year 2007. The other numbers are marketing codes used at the manufacturer's discretion. This information is for contacting consumers if a tire defect requires a recall.

Illustration courtesy of NHTSA, www.safercar.gov

Section 5: Weighing, Loading, and Towing

Introduction

WARNING

Do not exceed any applicable motorhome weight ratings. Doing so could damage your motorhome or affect handling and braking characteristics.

Your motorhome's braking system is designed and rated for operation at the gross vehicle weight rating (GVWR) listed on the unit's weight labels, not the gross combined weight rating (GCWR).

CAUTION

A supplementary braking system should be used for safe control of towed vehicles and for trailers weighing more than 1,500 pounds when loaded. Supplemental braking systems are required by transportation laws.

Proper loading of the vehicle is one of the most important considerations when traveling in a motorhome. Your motorhome is designed to carry a certain safe maximum load. This is the Gross Vehicle Weight Rating, or GVWR. When towing a trailer or vehicle, the added weight calculates towards the total weight of your motorhome (Gross Combined Weight, or GCW). Staying within the weight limits of your motorhome will help to ensure your motorhome performs and operates safely for your journeys.

Both the chassis manufacturer and Thor Motor Coach provide weight ratings and recommendations for loading your motorhome. Read and follow the information provided by the chassis manufacturer in the chassis manufacturer's owner's manual as well as information provided by Thor Motor Coach in this owner's manual. Important weight ratings are listed on labels affixed to your motorhome. Do not remove these important safety labels.

NEVER LOAD YOUR MOTORHOME OR TOW A TRAILER OR VEHICLE THAT IS BEYOND THE SAFE TOWING CAPACITIES AND WEIGHT-CARRYING RATINGS OF YOUR MOTORHOME AND TOWING HITCH.

Important Weight Terminology

Listed on the following pages are several important terms that you need to become familiar with in order to safely load and use your motorhome as a towing vehicle. Please review your chassis owner's manual for additional information provided by the chassis manufacturer.

Curb Weight:

The weight of an unloaded motorhome plus the weight of a full tank of fuel. Does not include propane, water, passengers, cargo, or aftermarket add-ons.

Unloaded Vehicle Weight (UVW):

The curb weight of the unloaded motorhome plus a full propane tank.

Cargo Weight:

The total weight of all cargo added to your motorhome, including food, clothing, camping gear, pots and pans, tools, water (fresh and waste), propane, and all aftermarket equipment added to the motorhome. Also includes trailer tongue weight. Keep in mind, carrying unnecessary water quantities (fresh or waste) adds significantly to the total cargo weight:

NOTE: 1 gallon of water = 8.3 pounds

1 gallon of propane = 4.2 pounds

1 gallon of gasoline = 6 pounds

1 gallon of diesel fuel = 7 pounds

Occupant and Cargo Carrying Capacity (OCCC):

The maximum weight of all cargo and occupants that can be safely carried by the motorhome. The tongue weight of your towed trailer or vehicle must be included in the total cargo weight. **DO NOT EXCEED THE OCCC RATING OF YOUR MOTORHOME.**

OCCC is determined by subtracting the UVW of the motorhome from the GVWR of the chassis, plus the weight of any carried LP fuel. The OCCC of your motorhome is listed on the yellow OCCC label, affixed to the forward, right-side entry or passenger door.

Gross Vehicle Weight Rating (GVWR):

The maximum permissible weight of a fully loaded motorhome. GVWR is determined by the chassis manufacturer and takes into consideration the design of the frame, suspension components, axles, and tires. This rating can be found on the Incomplete Vehicle Identification Data Label affixed to the driver's door jamb.

Gross Vehicle Weight (GVW):

The actual measured weight of your loaded vehicle. $\text{Gross Vehicle Weight} = \text{Curb Weight} + \text{Total Cargo Weight} + \text{Total Passenger Weight}$. **THE MEASURED GVW MUST NEVER EXCEED THE GVWR OF THE MOTORHOME.**

5

WEIGHING, LOADING, AND TOWING

Gross Combined Weight Rating (GCWR):

The maximum allowable loaded weight of this recreational vehicle, including the weight of its towed trailer or towed vehicle. This rating is determined by the chassis manufacturer and takes into consideration the design of the chassis, suspension components, tires, engine torque and horsepower, and drivetrain components.

Gross Combined Weight (GCW):

The actual measured combined weight of your loaded motorhome plus the weight of your loaded trailer or towed vehicle. This weight measurement is found by weighing the motorhome with its towed vehicle on a commercial vehicle scale. **THE MEASURED GCW MUST NEVER EXCEED THE GCWR OF THE MOTORHOME.**

Gross Axle Weight Rating (GAWR):

The value specified as the load carrying capacity of a single axle system, as measured at the tire ground interfaces. This rating is determined by the manufacturer of the chassis. This rating can be found on the Federal Weight Label, affixed to the driver's door jamb (Class C and B) or near the driver's seat (Class A).

Gross Axle Weight (GAW):

Gross axle weight is the total weight of the fully loaded motorhome on each axle. This weight figure is determined by actually weighing the fully loaded motorhome with a

loaded trailer or towed vehicle. See your owner's manual for instructions on weighing your motorhome.

Tongue Weight:

Weight directly transferred to the hitch of the motorhome by a loaded trailer. The maximum tongue weight is listed on the motorhome's hitch label. Be sure that tongue weight never exceeds the GAWR of the rear axle of the motorhome. **DO NOT EXCEED THE TONGUE WEIGHT RATING OF THE HITCH.**

When loading a trailer, remember to place heavy cargo over the axle(s) of the trailer, however the trailer must have some tongue weight to help stabilize the trailer while being towed.

Maximum Loaded Trailer Weight:

The highest possible weight of a fully loaded trailer or towed vehicle the motorhome can tow based on a minimally loaded motorhome (GVW).

Towing Capacity:

Towing capacity is determined by subtracting the measured Gross Vehicle Weight (GVW) from the Gross Combined Weight Rating (GCWR). **DO NOT EXCEED THE TOWING CAPACITY RATING OF THE HITCH AND YOUR MOTORHOME.**

Federal Weight Label

The Federal Weight Label is typically affixed to the driver's doorjamb for Class B and C motorhomes. This label concisely states the gross vehicle weight rating (GVWR) of your motorhome, along with the gross axle weight rating (GAWR) (both

front and rear), tire size, tire weight rating, and proper tire inflation. This information meets the requirements of 49 CFR part 571.120 as issued by the National Highway Traffic Safety Administration (NHTSA).

MANUFACTURED BY: THOR MOTOR COACH, INC.			OFFLINE: MM/YY		
GVWR: XXXX KG (XXXXX LB)			SERIAL: XXXXXXXXXXXXXXX		
INC. VEH. MFG. BY: <Insert Chassis Manufacturer>			MODEL: XXXX		
GAWR KG(LB)	TIRES	RIMS	COLD INFLATION PRESSURE	SINGLE	DUAL
FRONT: XXXX (XXXX)	LT215/85R16	5.5 J X 16	XXX KPA(XX PSI)	<input type="checkbox"/>	<input type="checkbox"/>
REAR: XXXX (XXXX)	LT215/85R16	5.5 J X 16	XXX KPA(XX PSI)	<input type="checkbox"/>	<input type="checkbox"/>
TAG:				<input type="checkbox"/>	<input type="checkbox"/>
THIS VEHICLE CONFORMS TO ALL APPLICABLE U.S. FEDERAL MOTOR VEHICLE SAFETY STANDARDS IN EFFECT IN MM/DD/YYYY					
V.I.N.: XXXXXXXXXXXXXXXXXX			TYPE: MULTIPURPOSE PASSENGER VEHICLE		

Typical Federal Weight Label, including GVWR, GAWR, and tire pressure information

Occupant and Cargo Carrying Capacity Weight Label (OCCC)

The Motorhome Occupant and Cargo Carrying Capacity (OCCC) weight label is affixed to the interior side of the forward-most passenger door of Class B and C motorhomes. This label indicates how much passenger and cargo weight you can safely carry within the motorhome. The total weight of passengers, cargo, water (fresh and waste), and trailer tongue weight should never exceed the weight values shown on this label.

This label also includes important safety belt seating capacity information and the measured overall length of the motorhome.

NOTE: If a boat, trailer, or other vehicle is being towed, it should be weighed and combined with the motorhome's weight to ensure the total weight of the motorhome and towed vehicle does not exceed the gross combined weight rating (GCWR) of the motorhome. Contact your dealer or the chassis manufacturer for GCWR ratings.

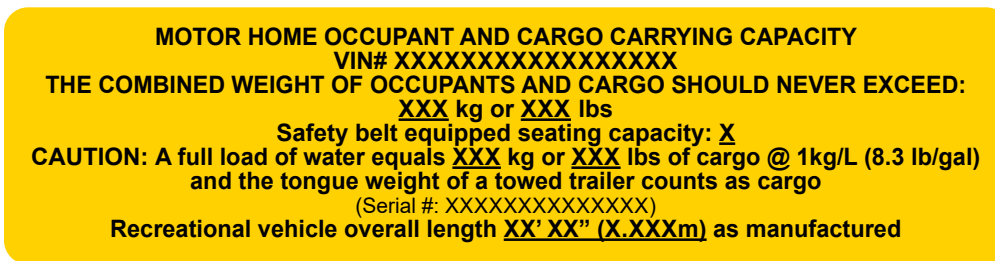

Typical Motorhome Occupant and Cargo Carrying Capacity Label

Alterer Label (USA)

An Altered By (Manufacturer) label may be affixed to the driver's door jamb of Class B motorhomes.

This label states that as an altered vehicle (modified by TMC from its original chassis manufacturer's form), the

motorhome conforms to all safety, bumper, and theft prevention standards affected by the alternation as in effect by the manufactured date.

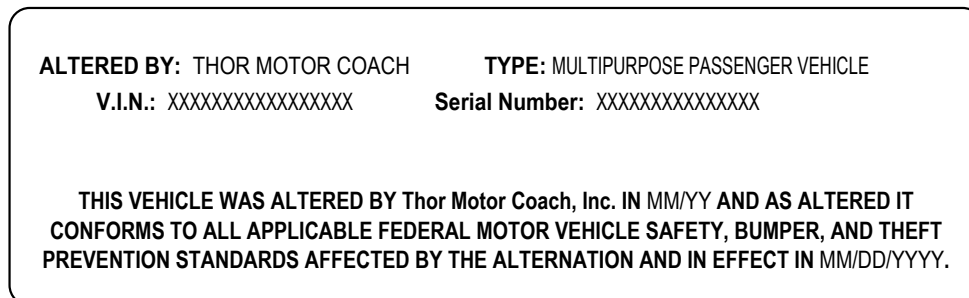

5

WEIGHING, LOADING, AND TOWING

Canadian Weight Label / Statement of Compliance

For the Canadian market, a dual language (English/French) weight label is affixed to the driver's-side door jamb for Class B and C motorhomes and near the driver's seat for Class A motorhomes.

This label concisely states the gross vehicle weight rating (GVWR) of your motorhome, along with the gross axle weight

rating (GAWR) (both front and rear), tire size, tire weight rating, and proper tire inflation. This label states that the motorhome conforms to all applicable standards prescribed under the Canadian Motor Vehicle Safety Regulations in effect on the date of manufacturer.

MANUFACTURED BY/FABRIQUE PAR: THOR MOTOR COACH, INC. GVWR/PNBV: XXXX KG (XXXXX LB) Received: XX/XX/XXXX DESIGNATED SEATING CAPACITY/NOMBRE DESIGNE DE PLACES ASSISES: (X) X 68 = XXXXKG			OFFLINE: MM/YY SERIAL: XXXXXXXXXXXXXXXX MODEL: XXXX		
GAWR/PNBE KG(LB)	TIRES/PNEU	RIMS/JANTE	COLD INFL. PRESS./PRESS. DE CONFL. A FROID	SINGLE	DUAL
FRONT/AVANT: XXXX (XXXX)	XXXXXX/XXXXXX	XXX X XX	XXX KPA(XX PSI)	<input type="checkbox"/>	<input type="checkbox"/>
REAR/ARRIÈRE: XXXX (XXXX)	XXXXXX/XXXXXX	XXX X XX	XXX KPA(XX PSI)	<input type="checkbox"/>	<input type="checkbox"/>
TAG/ARRIÈRE: X				<input type="checkbox"/>	<input type="checkbox"/>
<small>THIS VEHICLE CONFORMS TO ALL APPLICABLE STANDARDS PRESCRIBED UNDER THE CANADIAN MOTOR VEHICLE SAFETY REGULATIONS IN EFFECT ON THE DATE OF MANUFACTURER - CE VÉHICULE EST CONFORME À TOUTES LES NORMES APPLICABLES EN VERTU DU RÉGLEMENT CANADIEN SUR LA SÉCURITÉ DES VÉHICULES AUTOMOBILES EN VIGUEUR À LA DATE DE FABRICATION</small>					
<small>V.I.N./N.I.V.: XXXXXXXXXXXXXXXXX</small>			<small>TYPE OF VEHICLE/TYPE DE VÉHICULE: MH (MOTORHOME)/AC (AUTOCARAVANE)</small>		

Typical Canadian weight label

Canadian Cargo Carrying Capacity Label

For the Canadian market, a dual language Cargo Carrying Capacity (CCC) (English/French) label is affixed to the driver's-side door jamb for Class B and C motorhomes and near the driver's seat for Class A motorhomes.

This label states the cargo carrying capacity (in kilograms) of the motorhome and is calculated with full freshwater holding tanks, including a full hot water heater, if applicable.

CARGO-CARRYING CAPACITY: XXX KG. CALCULATED WITH THE Freshwater TANKS FULL (COLD): XX KG. (HOT): XX KG. AND THE WASTEWATER TANKS EMPTY	CAPACITE DE CHARGEMENT: XXX KG. CALCULEE AVEC LES RESERVOIRS D'EAU DOUCE PLEINS (FROID) (CHAUD) XX KG. XX KG. ET LES RESERVOIRS D'EAUX USEES VIDES.
MASS OF WASTEWATER TANKS FULL: XX KG. V.I.N./N.I.V.: XXXXXXXXXXXXXXXXX	MASSE DES RESERVOIRS D'EAUX USEES PLEINS: XX KG.

Canadian Recreational Vehicle Length Label

For the Canadian market, a dual language recreational vehicle length label is located on the most forward passenger side

door. For Class A motorhomes, this location description applies to the main right-side entrance door.

THOR MOTOR COACH

NIV#/VIN#: XXXXXXXXXXXXXXXXXX / SERIAL: XXXXXXXXXXXXXXXXXX

THORMOTORCOACH.COM

Longueur hors tout du véhicule de loisirs XX' X" (XXm) tel que fabriqué
Recreational vehicle overall length XX' X" (XXm) as manufactured

Alterer Label (Canada)

An Altered By (Manufacturer) label may be affixed to the driver's door jamb of Class B motorhomes.

motorhome conforms to all safety, bumper, and theft prevention standards affected by the alternation as in effect by the manufactured date.

This label states that as an altered vehicle (modified by TMC from its original chassis manufacturer's form), the

ALTERED BY / MODIFIÉ PAR: THOR MOTOR COACH
V.I.N. / N.I.V: XXXXXXXXXXXXXXXXXX SERIAL NUMBER: XXXXXXXXXXXXXXXXXX
DESIGNATED SEATING CAPACITY / NOMBRE DESIGNE DE PLACES ASSISTER: THOR MOTOR COACH
TYPE OF VEHICLE / TYPE DE VÉHICULE: TMH (MOTOR HOME0 / AC (AUTOCARAVANE)

THIS VEHICLE CONFORMS TO ALL APPLICABLE STANDARDS PERSCRIBED UNDER THE CANADIAN
MOTOR VEHICLE SAFETY REGULATIONS IN EFFECT ON THE DATE OF MANUFACTURE - CE VÉHICULE
EST CONFORME À TOUTES LES NORMES APPLICABLES EN VERTU DU RÈGLEMENT CANADIEN
SUR LA SÉCURITÉ DES VÉHICULES AUTOMOBILES EN VIGUEUR À LA DATE DE FABRICATION.

CMVSS Label

All U.S. and Canadian market Class B motorhomes that have been modified with a camper-top (SkyBunk®) have this notification label installed on the Driver's sun visor.

**This vehicle has a modified roof, and
CMVSS 226 – EJECTION MITIGATION
does not apply to this vehicle. / Ce véhicule
a un toit modifié et la NSVAC 226 –
RÉDUCTION DES RISQUES D'ÉJECTION
ne s'applique pas à ce véhicule.**

5

WEIGHING, LOADING, AND TOWING

Weighing Your Motorhome

When loading your cargo, be sure weight is distributed evenly to prevent overloading front to back and side to side. Heavy items should be placed low and as close to the axle positions as possible. Too much weight loaded on one side or the other may overload tires and cause handling issues.

Periodically weigh your motorhome at a public vehicle scale to determine axle loads. You can find certified public or commercial vehicle scales at moving and storage lots, farm suppliers with grain elevators, gravel pits, recycling companies, and large commercial truck stops.

To weigh your motorhome correctly, measure the fully loaded vehicle axle by axle and wheel position by wheel position. Allow adequate time, since the entire weighing process can take around 30 minutes. There may be a small fee for each weight reading taken, but the expense is a worthwhile investment toward the safe operation of your motorhome.

Your motorhome must be weighed fully loaded, which includes passengers, food, clothing, fuel, water, propane, supplies, etc. Any towed vehicle (boat, or trailer) or items loaded on brackets on the back or roof of the motorhome should also be included in the weighing process.



Reading A: Front



Reading B: Total Coach



Reading C: Back

The thick black line in the illustrations above represent a vehicle weighing scale.

The following procedure is suggested when using a long platform scale, although any method recommended by the scale operator which correctly determines weight value is acceptable. During all measurements, it is important to keep the vehicle as level as possible.

1. Pull onto the scale so that only the front axle is on the platform with the end of the scale midway between the front and rear axles and record the weight (Reading A).
2. Pull forward until the full unit is on the scale and record the weight (Reading B).
3. Pull forward so that only the rear axle is on the scale and record the weight (Reading C).
4. To determine the weight of individual wheel positions, repeat the previous three steps, but this time, use only one side of the motorhome on the scale. Record the weight readings.
5. To calculate the wheel position weight for the opposite side of the motorhome, subtract these weight readings from weight readings A, B, and C recorded in steps 1, 2, and 3.

Other factors to consider:

- Your motorhome must remain as level as possible on the scale, even though an axle or side is not physically on the scale. To obtain the side-to-side weights, there must be enough space on either side of the scale to allow the motorhome to be partially off the scale.
- For improved accuracy and whenever possible, use a segmented 4-pad scale to determine individual wheel weights. The corner weights should not exceed half of the respective Gross Axle Weight Rating (GAWR) or the maximum load rating for the tire or set of dual tires at the rear, whichever is less.
- Individual wheel position weights must not exceed the maximum tire load capacity. The maximum load rating for the tire can be found embossed on the tire's sidewall.
- If any of the corner weights exceed half of the listed GAWR or tire ratings, redistribute or remove a portion of the cargo until the weight is within the proper limits for all four corners of the vehicle.
- Periodically check and adjust your motorhome's cargo weight to obtain optimum mileage from your tires and to optimize vehicle handling. Tires should always be inflated as recommended on the Federal Weight Label affixed to your motorhome.

Weight Distribution

Proper loading and weight distribution are extremely important items to consider for safe motorhome travel. An overloaded motorhome is hard to drive and hard to stop. In cases of serious overloading, brakes can fail completely, particularly on steep hills. Proper weight distribution also affects tire performance, while overloading can cause premature wear to the vehicle's engine, transmission, and drive train components. The load a tire will safely carry is a combination of its size, its construction, its load range, and corresponding inflation pressure.

Improper weight distribution, or too much weight on your motorhome's suspension system, can cause failure or damage to:

- Springs and suspension components
- Shock absorbers
- Brakes
- Tires
- Steering components

Loading Your Motorhome

Always consider proper vehicle loading when preparing for travel. By not overloading the motorhome and keeping the weight balanced side-to-side and as close to the axles as possible, the drivability and safe handling of the vehicle will be maximized.

- Never overload your motorhome. Always observe and stay under the GVWR and OCCC ratings.
- Distribute cargo side-to-side so the weight on each tire does not exceed one-half of the GAWR for either axle.
- Store and secure all loose items inside the motorhome before traveling. Overlooked items such as canned goods, small appliances on the countertop, cooking pans on the range, or free-standing furniture items can become dangerous projectiles during a sudden stop.
- When traveling, keep the quantity of fresh, gray, and black water within the storage tanks to a minimum. This reduces the total weight of the motorhome, therefore increasing available carrying weight for other items (refer to Occupant Cargo Carrying Capacity (OCCC) of the motorhome).
- Give careful attention to where and what type of flammable materials you store and transport. Certain storage areas are clearly labeled **DO NOT STORE COMBUSTIBLE MATERIALS**. Be sure all canisters are secure and leak free. **DO NOT TRANSPORT LP TANKS OR CANISTERS INSIDE THE VEHICLE** (see Propane Section).

- For traveling safety, it is important to make sure tie down straps on appliances, furniture, and cargo (inside the vehicle) and cargo (outside the vehicle) are secured and remain tight. Check straps regularly to ensure they have not loosened during travel.
- Be sure not to overload roof racks with cargo that is heavier than the load-carrying capacity of the roof rack system.
- If you are towing a trailer or vehicle, be sure to stay under the towing capacity of your motorhome and that the added weight stays under the GCWR for your motorhome.

NOTE: At approximately 8 pounds per gallon, water can add a considerable amount of weight to your motorhome. Additional cargo carrying capacity for other items can be obtained by reducing the amount of fresh and wastewater carried while traveling.

However, it is recommended to always keep a few gallons of water in the black tank to help prevent the build-up of sludge, which can lead to wastewater system blockages.

Towing With Your Motorhome

WARNING

NEVER TOW LOADS THAT EXCEED EITHER THE TOW WEIGHT RATING AND/OR THE TONGUE WEIGHT RATING OF THE TRAILER HITCH INSTALLED ON THE MOTORHOME (Note: Tow weight is the total weight of a fully loaded trailer or towed vehicle. Tongue weight is the downward weight in pounds transferred to the hitch by the loaded trailer or towed vehicle).

THE WEIGHT OF THE FULLY LOADED MOTORHOME AND THE WEIGHT OF THE TRAILER, OR TOWED VEHICLE, MUST NOT EXCEED THE MOTORHOME'S GROSS COMBINED WEIGHT RATING (GCWR). Consult with your selling dealer to determine the GCWR and towing capacity of the motorhome.

THE DESIGNATED HITCH RATING MAY EXCEED THE GCWR OR OTHER TOWING CAPACITY LIMITS OF THE MOTORHOME. It is your responsibility to properly load the motorhome and trailer, while staying within the limits of the hitch ratings, GCWR, GVWR, and GAWR specified on the certification label(s) of the motorhome.

A SEPARATE FUNCTIONING BRAKE SYSTEM IS REQUIRED FOR CONTROLLING ANY TOWED TRAILERS OR VEHICLES WEIGHING MORE THAN 1,500 LBS WHEN FULLY LOADED. Do not assume the braking capabilities of the motorhome can also adequately stop the combined weight of the motorhome and towed vehicle. For specific towed vehicle braking requirements, consult your chassis owner's manual.

⚠️ WARNING

Consult with your dealer and/or the chassis manufacturer regarding the suitability and safe use of weight-distributing hitches and other towing guidelines for this vehicle.

Failure to heed any part of these warnings could result in loss of control of the motorhome and towed vehicle or trailer and may cause an accident and severe injury.

⚠️ CAUTION

TMC Motorhomes are factory equipped with a towing hitch and wiring harness. However, TMC motorhomes are not factory equipped with supplemental trailer braking systems. Always have trailer braking systems professionally installed and routinely inspected by a qualified technician.

If you are unsure of any aspect of safe towing, seek professional advice from a reputable hitch installer, trailer, or RV dealer.

Towing Hitch

Your motorhome is equipped with a 3,500-pound rated, towing hitch receiver and trailer wiring receptacle. Please refer to the chassis manufacturer's owner's manual for towing recommendations and towing limitations for this vehicle.

If you are considering towing a trailer behind your motorhome, consult with your dealer or qualified towing expert about available towing equipment and towing options appropriate for your motorhome and travel needs.

NOTE: Thor Motor Coach accepts no responsibility for damage to the chassis and other components resulting from towing with this vehicle.

Electrical Connections for Towing

A 4-way or 7-way trailer plug, supplied by the chassis manufacturer, is pre-wired to the chassis electrical system. This plug provides electrical power for running lights, turn signals, stop lights, and electric trailer brakes. Before connecting your motorhome to any towed vehicle, verify that the wiring of the towed vehicle plug conforms to your motorhome connector wiring.

Refer to the vehicle manufacturer's owner's manual for additional information regarding vehicle towing.

7-Way Connector Wiring

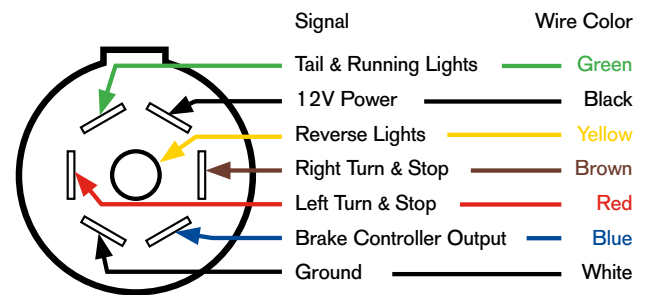

4-way Connector Wiring

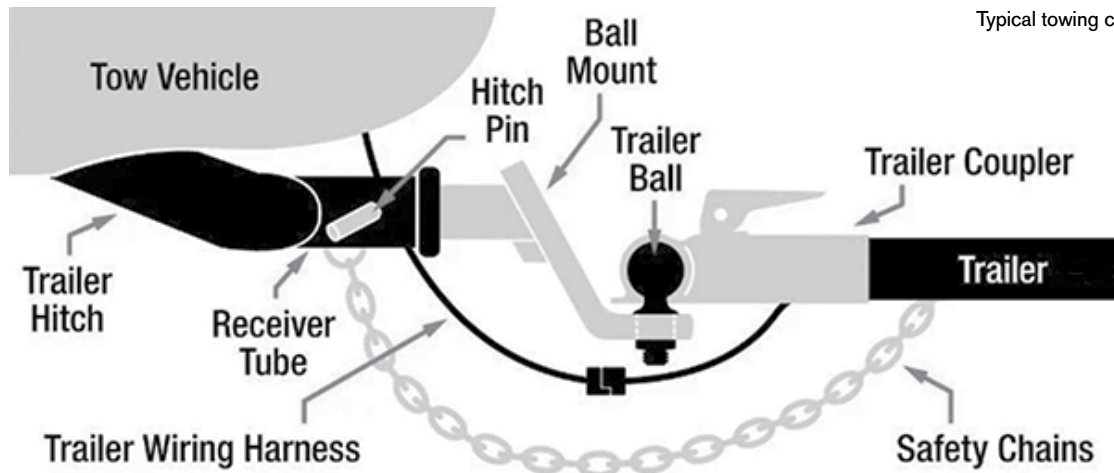
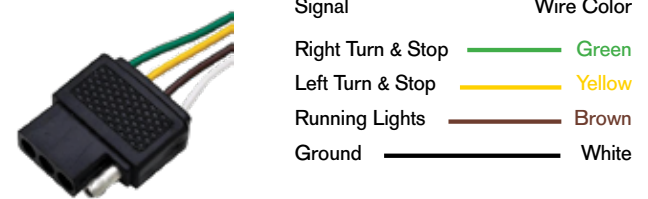

Typical towing components

Safe Towing Tips

- Never exceed the hitch tow rating, the hitch tongue weight rating and the towing capacity of your motorhome. Exceeding the maximum towing capacity can result in dangerous handling, insufficient braking performance, or serious damage to the vehicle's suspension, engine and drive train.
- Make sure your trailer hitch is capable of handling your trailer's loaded weight.
- When loading and towing with your vehicle, do not exceed the GVWR and GCWR of your motorhome.
- There are several sizes of trailer balls available. **BE SURE THE TRAILER BALL MATCHES THE SIZE OF THE TRAILER COUPLER!**
- Always ensure the trailer coupler is properly seated and locked onto the trailer ball (see illustration).
- Always ensure the hitch pin is properly installed, securing the ball mount to the receiver tube (see illustration).
- Always use safety chains between your motorhome and the towed trailer or vehicle. Cross the chains under the trailer tongue and allow slack for turning corners. Connect the safety chains to the trailer or vehicle frame or hook retainers. Never attach safety chains to the bumper of a vehicle (see illustration).
- Always check brake lights, running lights, emergency flashers, and turn signals of the motorhome and trailer (or towed vehicle) at the start of the trip and often during the trip.

Accidents can occur if the taillights are not working or are improperly connected. Have a partner stand behind the vehicle, **while it is in PARK**, to check that the turn signals, taillights and brake lights are functioning properly.

- Always pack your trailer so that most of the weight is over the axles, yet allowing sufficient tongue weight for safe control of the trailer.

Not only do you want roughly 60% of the trailer's load placed over the front half of the trailer, you also should load it in a way that results in a tongue weight that is between 10-15% of the total weight of the loaded trailer. Ensure weight is evenly distributed on the left and right sides of the trailer. Once the load is properly distributed and an ideal tongue weight is achieved, all cargo should be secured to prevent the load from shifting.

- Check both **TRAILER AND MOTORHOME** tires daily for proper inflation and for any unusual wear (check tire pressure with cold tires). Do not forget the inner tires of the dual tire/wheel set-up and spare tires for both the motorhome and trailer.

Tires that are not properly inflated can negatively affect handling. Further, under-inflated tires can create more rolling resistance, which not only forces the engine to work harder and consume more fuel, but also increases

tire temperatures and may contribute to a blow-out. Additionally, check the speed and load rating on the tires for both your motorhome and trailer, and ensure you never exceed that these limits.

- Check your trailer's hub bearings before starting your trip, and often during your travels. Ensure bearings are in good order and properly greased.
- Check trailer brakes at the start of each trip and daily. Smaller, lighter trailers may not need trailer brakes of any kind, but heavier trailers, or those designed to carry heavier loads, will usually incorporate a trailer brake system. If your trailer is equipped with hydraulic or electric surge brakes, make sure the emergency "break-away" cable is properly attached to your tow vehicle. In case your trailer somehow disconnects from the hitch, this cable is designed to trigger the brakes on the trailer and quickly bring it to a halt.
- Adjust your mirrors. Before taking off, make sure your side view mirrors are adjusted to create a clear view that extends to the end of the trailer.
- Ensure your back-up cameras are in proper working order. Some cameras may be able to be placed in monitor mode, so that the towed vehicle can be observed while traveling.
- Tow bars or car dollies generally are made to travel in a forward direction only. Most towing equipment of this type is not designed for backing. Never attempt back-up maneuvers with a tow bar or tow dolly; doing so could result in damage to the motorhome, towed vehicle or towing device.
- Be mindful of the extra length a trailer or towed vehicle adds to your motorhome. Your motorhome is a long vehicle, and with the added length of a trailer, it can be very long. Be extra careful when merging into traffic or making lane changes. Allow extra time to make these maneuvers. **ALWAYS SIGNAL YOUR INTENTIONS WITH PROPER USE OF TURN SIGNALS.**
- Allow for extra braking distance caused by the added weight of a trailer or towed vehicle.
- Be extra cautious when making turns. Allow for the extra length and large turning radius caused by the added length of the trailer or towed vehicle.
- Use the aid of a spotter when backing the trailer. Be sure the spotter is always in view of your rear-view mirrors. **STOP THE VEHICLE IF YOU CANNOT SEE YOUR SPOTTER.**
- Always chock trailer or towed vehicle wheels when disconnected from the towing vehicle (motorhome) or when parking on an incline.

Reference: <https://www.gmc.com/gmc-life/trucks/tips-for-safe-trailer-and-towing>

This page is intentionally blank

Awning

CAUTION

TO PREVENT PERSONAL INJURY, DAMAGE TO THE AWNING, OR MOTORHOME:

- Retract all awnings during periods of strong winds or threatening weather.
- Do not move or drive the motorhome with the awning in the extended position. Always retract the awning completely before moving the motorhome.
- Keep hands away from awning mechanisms while in operation. Mechanisms present pinch points that can cause severe injury.
- Keep all sources of heat and flame away from the awning canopy. Fabric is not fireproof.

NOTICE

- If awning is rolled up wet, open it back up as soon as possible to allow awning to dry. Stowing a damp awning can create mold or mildew formation.
- When leaving the motorhome unattended for a length of time, retract the awning to avoid damage due to unexpected weather conditions.
- Do not hang or attach items to the awning. Awnings are not designed to support additional weight.
- In the event of power loss or awning motor failure, motorized awnings can be manually retracted (refer to the awning manufacturer's owner's manual for instructions).

Awnings can create a pleasant outdoor space that provides shade from the sun and semi-protection from certain weather conditions.



The patio awning operates from the motorhome's 12-volt DC electrical supply. The master battery switch will need to be ON prior to operating the awning.

To extend the awning:

1. Before extending the awning, ensure there are no obstacles in the path of operation.
2. Provide power to the awning by turning ON the master battery switch, or operate the generator, or connect to shore power.
3. Press (**do not hold**) the EXTEND switch, located near the entrance door, or on the multiplex touchscreen panel, or remote (see note), until the awning is opened to the desired position.

NOTE: For Class B motorhomes outfitted with a SkyBunk Pop-top Bunk, the EXTEND switch **must be continuously held** while extending the awning.

4. Press the switch again to stop the awning at the desired position.
5. **ALWAYS** Use the adjustable prop rods to support and adjust the angle of the fully extended awning. Prop rods can be placed vertical to the ground or attached to brackets located on the side of the motorhome. Depending on the awning model, prop rods may be separate or located on the inside edge of the awning fascia.

To retract the awning:

1. Before retracting the awning, ensure there are no obstacles in the path of operation.
2. Collapse and stow the prop rods.
3. Provide power to the awning by turning ON the master battery switch, or operate the generator, or connect to shore power.
4. Press (**do not hold**) the RETRACT switch, located near the entrance door, or on the multiplex touchscreen panel, or remote (see note). The awning will fully retract; or press the switch again to stop at a desired partially-open position.

NOTE: For Class B motorhomes outfitted with a SkyBunk Pop-top Bunk, the RETRACT switch **must be continuously held** while retracting the awning.

NOTE: The multiplex system may offer remote control of awnings and other electrical systems via a smartphone or tablet app.

6

EXTERIOR FEATURES AND COMPONENTS

Lighted Entry Step (if equipped)

Your TMC motorhome may be equipped with a lighted running-board style entry step. The light automatically illuminates when the side sliding door is opened and remains illuminated for a brief time after the door is closed.

Always be sure of solid footing and use handrails whenever entering or exiting your motorhome.

Roof

⚠ WARNING

The roof of this vehicle is not designed to support people. Do not climb on or walk on the roof. Do not use the roof as an observation platform.

Doing so could result in damage to the vehicle and/or a fall, leading to severe injury or death.

Maintenance of all roof-mounted devices should be done from a ladder or other safe means. Do not climb upon or walk on the roof. Damage to the vehicle's structure and the possibility of an injurious fall exists.

Roof Rack (if equipped)

Your motorhome may be equipped with a factory-installed roof rack system. Cross-members are not included, but are available from the roof rack manufacturer or your dealer. Factory-installed solar panels may be attached on or between the roof rack. Information for the roof rack is included in your TMC Owners' Packet.

Light Bar

⚠ CAUTION

The light bar installed on this vehicle is for OFF-ROAD use ONLY. DO NOT use the light bar for ON-ROAD illumination. The light bar projects a powerful beam of light, which could be extremely hazardous to on-coming traffic.

Traffic laws may require covering the light bar whenever the vehicle is driven on-road. Always adhere to state and local laws pertaining to the legal use of accessory lighting devices.

TMC Class B motorhomes may be equipped with an accessory light bar (only available on select TMC Class B motorhomes). This lighting unit consists of powerful flood and spotlights. The light bar is for **OFF-ROAD USE ONLY**. Check state and local laws for regulations that pertain to the legal use of accessory vehicle lighting.

Side Door Screen (if equipped)

⚠ CAUTION

Do not drive the vehicle while the side sliding door is open.

Do not drive the vehicle while the back door or doors are open. Dangerous exhaust fumes could enter the vehicle.

For convenient ventilation and insect control when parked, your class B motorhome may be equipped with side and rear door screens. Style, actuation, and fastening vary depending on model and floor plan.

To operate sliding screen:

1. From the outside, fully open the right-side sliding door.
2. With even pressure from top-to-bottom, carefully pull the screen from its stowed position across the opening of the right-side sliding door.
3. Reverse this procedure when returning the screen door to its stowed position and when preparing for travel.



Side-door screen. Screens and fastening styles may vary from this illustration.

Rear Door Screen (if equipped)

⚠ CAUTION

Do not operate the engine or drive the vehicle while the back door or doors are open. Dangerous exhaust fumes could enter the vehicle.

For convenient ventilation and insect control when parked, a rear door insect screen is available. The screen is held in place with twist fasteners, hooks, or other devices and has a center opening, which is usually held together with magnets.

The screen can be left in place with the back doors closed or can be easily rolled-up or removed and stowed when not needed.

NOTE: Side and rear door screens may differ from the illustrations here, yet all factory-installed door screens will function as insect control and ventilation devices.



Rear door screen

Bicycle Rack (if equipped)

Your motorhome may be equipped with a bicycle rack attached to the rear door. This rack allows convenient and secure transportation of one or two bicycles. For operational instructions, refer to the manufacturer's owner's guide included in your TMC Owner's Packet.

NOTE: Additional information covering the operation and maintenance of exterior-mounted features and devices of your motorhome may be available through the on-line TMC Owners Resource Information Service and TMC How-to videos:

www.thormotorcoach.com/owners/



Bicycle rack attached to the rear door

This page is intentionally blank

Section 7: Interior Features and Components

Your TMC Class B motorhome is well appointed with appliances and entertainment devices that make on-the-road travel convenient and enjoyable. Most floor plans are appointed similar to larger RV's, just on a smaller scale. These features are covered in this section.

Interior Lighting

The interior lighting installed in your Thor Motor Coach motorhome provides safe and convenient illumination for the living space of your RV. All interior lighting fixtures, which include ceiling, reading, accent, and safety illumination operate on 12-volts DC. Most, if not all, interior lighting comprises of energy-efficient and long-lasting LEDs.

Controls for interior lights are located on wall-mounted switches or switch panels. Multiplex systems include a master lighting control menu. Some accent lighting fixtures have a built-in push-on, push-off switch located in the center of the fixture cover.

Powering the Lighting System

Since all interior lighting fixtures operate on 12-volt DC power, the motorhome's 12-volt DC power system must be activated.

To operate lighting fixtures by the on-board 12-volt auxiliary battery or Battery Power system:

1. Turn ON the main battery disconnect switch, located near the main entrance door of the motorhome.
2. Operate interior lights as needed.



Typical interior ceiling and under-cabinet LED lighting

To operate lighting fixtures by shore power:

1. Connect the shore power cord to an external power source.
2. Operate interior lights as needed. Power for the lights (and other 12-volt devices) is sourced through the on-board converter (located within the power load center), which transforms incoming 120-volts AC to 12-volts DC.

To operate lighting fixtures by the on-board generator:

1. Turn the main battery disconnect switch ON (must be ON in order to start and operate the generator).
2. Start and operate the generator, then operate the interior lights as needed.
3. When the generator is running, power for the lights and other 12-volt devices is sourced through the on-board converter (located within the power load center), which transforms incoming 120-volts AC to 12-volts DC.

NOTES:

- Interior lighting controls may be integrated within the multiplex control system, with additional remote lighting switches located throughout the motorhome. Individual lighting icons that display an arrow are dimmable. Press and hold the light icon until the light fixture dims to the desired illumination level.
- When leaving the motorhome for longer than a few hours and not connected to shore power, it is good practice to turn off interior lighting and turn OFF the main battery disconnect switch. Doing so will prevent the auxiliary (house) battery from unnecessary discharging.

Appliances

⚠ DANGER

IF YOU SMELL PROPANE GAS

1. Extinguish any open flames and all smoking materials.
2. Shut off the propane supply at the container valve(s) or propane supply connection.
3. Do not touch or operate electrical switches.
4. Open doors and other ventilating openings.
5. Leave the area until the odor clears.
6. Have the propane system checked and leakage source corrected before using again.

Ignition of flammable vapors could lead to a fire or explosion and result in death or serious injury.

⚠ DANGER

DO NOT USE GAS COOKING APPLIANCES FOR COMFORT HEATING. CAN LEAD TO CARBON MONOXIDE POISONING, WHICH CAN CAUSE DEATH OR SEVERE INJURY.

DO NOT OPERATE GAS RANGES OR GAS COOKTOPS WHILE THE VEHICLE IS IN MOTION.

⚠ DANGER

TO PREVENT SPARKS AND POSSIBLE EXPLOSIONS OR FIRE, NEVER USE GAS APPLIANCES OR IGNITERS WHEN FUELING THE MOTORHOME OR RE-FILLING THE LP TANK.

⚠ WARNING

- RANGE COVERS MUST BE OPEN WHEN THE SURFACE BURNERS ARE IN OPERATION.
- DO NOT OPERATE COOKTOPS UNLESS PRIVACY CURTAINS, WINDOW CURTAINS, WINDOW BLINDS, OR OTHER FLAMMABLE MATERIALS ARE SAFELY SECURED AWAY FROM THE APPLIANCE OR REMOVED.
- DO NOT STORE COMBUSTIBLE MATERIALS ON OR NEAR GAS APPLIANCES.

May cause a fire, which could result in death or severe injury.

⚠ WARNING

GAS COOKING APPLIANCES NEED FRESH AIR FOR SAFE OPERATION. BEFORE OPERATING:

- Open vents or windows slightly or turn on exhaust fan prior to using cooking appliance.
- Gas flames consume oxygen, which should be replaced to ensure proper combustion.
- Range covers must be open when the surface burners are in operation.

Improper use can result in death or severe injury.

⚠ WARNING

TO AVOID POSSIBLE ELECTRICAL SHOCK:

Always inspect the power cord of the induction cooktop before use. DO NOT use the appliance if the power cord is damaged, frayed, or missing a ground pin.

⚠ WARNING

Read and follow all warnings and safe operating instructions for the appliances installed in your motorhome. Follow all safety labels, affixed to your motorhome and provided in this TMC Owner's Manual and your TMC Owner's Packet or available directly from the appliance manufacturer.

NOTE: Appliance brands, models and features depend on TMC Class B brands, floor plans, and available standard and optional features.



Typical TMC Class B kitchens include all the food preparation and storage features needed in a convenient and compact layout.

The kitchen of TMC's Class B motorhomes are well equipped with modern and convenient cooking and food storage appliances, yet in a compact arrangement that is perfectly suited for the camper-van environment. The factory-installed appliances either operate on electricity, propane gas, or a combination of electric and gas. Due to continuous design updates, complete appliance operational instructions are not included in this manual. Individual component operational manuals are included with your TMC Owner's Packet and available through your on-line TMC Owners Resource account.

Typical Kitchen Units Include:

- Solid-surface countertop
- Microwave Oven
- 12 volt DC Refrigerator
- Sink
- Propane or Induction Cooktop
- Cutting Board
- Storage

Please refer to the specific appliance component manufacturer's owner's manuals for safety, operation, and maintenance instructions. If the information is missing from your Owner's Packet, please have the brand, model, and serial number of your specific appliance available before contacting your selling dealership for assistance in obtaining a replacement. For your convenience, many appliance manufacturers have their component manuals available for download from their company website.

Appliance Warranties:

Each appliance installed in the motorhome is warranted by its manufacturer. It is very important to review ALL the literature provided in your TMC Owner's Packet. Fill out and submit warranty registrations as required by the appliance manufacturers. Your dealer can help you with this process.

Questions About Your Appliances:

Please contact your selling dealer, TMC Customer Care, or the appliance manufacturer if you have any questions regarding the safe operation, maintenance, or repairs of the appliances installed in your TMC camper van.

NOTE: Due to the wide variety of appliances installed in TMC motorhomes, appliance operational instructions are not included in this manual. Individual component operational manuals are included with your TMC Owner's Packet and also available through your on-line TMC Owners Resource document service.

www.thormotorcoach.com/owners/

Cooktops

Depending on the model and floor plan, TMC's camper-vans are equipped with either a gas or electric-induction cooktop (one or multiple burners). Induction cooktops operate on 120 volts AC and are typically designed to be portable, meaning that using them as an outside cooking appliance is possible. Prior to operating propane cooktops, the Main Gas Valve must be OPEN, along with the Master Battery Switch being ON, which provides 12 volts DC to the igniter. NOTE: some gas cooktops may have igniters that operate on an internal AA battery and not the house 12 volt DC electrical system.



Portable Induction Cooktop used on an external flip-down tabletop.

Refrigerators

Typically, TMC Class B motorhomes are factory-equipped with a 12 volt DC compressor-type refrigerator. However, depending on supply-chain and other factors, your motorhome may be equipped with other types of refrigerator units suitable for the camper-van environment.

Possible refrigerator types include"

- 12-volt compressor type
- 12-volt absorption type
- 120 volt compressor type

12-volt compressor type refrigerators have a compressor unit that operates on 12 volts DC. To operate, the Master Battery Switch must be ON, and remain on while the refrigerator is in use.

Absorption-type RV refrigerators use a heating element, a heat-transfer device, and a mixture of water and ammonia as a means of cooling the interior of the refrigerator. The heat source is supplied by a LP burner or an electric heating coil,

which may be powered by either 12 volts DC or 120-volts AC. Refrigerator control circuits operate on 12 volts DC, so both the LP Main Gas Valve and the Master Battery Switch must be ON to operate an absorption refrigerator.

It is possible that a 120 volt AC compressor-type refrigerator is installed in your Class B motorhome. If so, your motorhome will also include an inverter that is appropriately sized to operate the refrigerator and other 120 volt AC circuits.

Powering refrigerators during travel:

To keep the refrigerator operating while the motorhome is either in-transit or off-the-power grid, each type of refrigerator is provided with a unique method of power. If your motorhome has a 12 volt DC compressor-type refrigerator, it operates from the auxiliary battery(ies). Be sure the master battery switch is always ON when operating the refrigerator. During travel, the auxiliary battery(ies) are being recharged by the vehicle's alternator, so that the refrigerator can remain ON. When parked at a campsite, plug into shore power if available. Doing so will prevent the refrigerator and other electrical demands from depleting energy from the auxiliary battery(ies).

If your motorhome is equipped with a gas/electric absorption refrigerator, operate the refrigerator on gas (on-board LP) while in-transit. Be sure the main gas valve is ON at the LP tank and that the master battery switch is ON (supplying control circuitry with 12-volt power). Some states



Typical Class B Refrigerator located underneath the kitchen countertop.

have strict regulations regarding operating gas appliances while in-transit. Therefore, the voltage requirements of the heating element will determine whether you can operate the refrigerator on battery power alone or need to use the inverter to supply 120 volts AC to the refrigerator.

If your Class B motorhome is equipped with a 120 volt AC compressor-type refrigerator, you can either operate the refrigerator via the on-board generator (if equipped), or via the battery system and the on-board inverter.

Inquire with your dealer as to what type of refrigerator is installed in your TMC Class B motorhome and recommended ways to power your refrigerator while in transit.

For complete instructions on the refrigerator supplied with your motorhome, refer to the manufacturer's instructions provided in your Owner's packet. Also, refer to the TMC Quick Start Guide, Refrigerators, available through the TMC Owners Resource on-line document service.

NOTE: Stored food items may shift during travel. Use caution when opening the refrigerator door during and after travel.

Microwave and Microwave/Convection Ovens

For speed and convenience of food preparation, all TMC motorhomes are equipped with a microwave oven or a combination microwave/convection oven. However, combination microwave/convection ovens are not typically specified due to their inherent higher energy consumption. Microwave ovens are appropriately sized, matching the design and compactness of the motorhome's kitchen and floorplan. All microwave ovens operate on 120-volts AC, which is either supplied by shore power, by the on-board generator (if equipped), or the Lithium-Ion battery power system (via the system's inverter).

For complete safety and operational instructions for the microwave oven installed in your motorhome, refer to the manufacturer's instructions provided in your Owner's packet or available on-line through your TMC Owners Resource account.

NOTE: Using 120 volt AC appliances via the on-board auxiliary battery(ies) and system inverter can rapidly deplete battery reserves. Always monitor battery condition while using 120 volt AC appliances and devices.

Entertainment Systems

TMC motorhomes are factory-equipped with many different entertainment devices, depending on motorhome model, floor plan, and available optional equipment.

For more detailed information regarding a specific component installed in your motorhome please refer to the respective component manufacturer's owner's manuals included your TMC Owner's Packet or download from the Owners Resource section of the TMC website.

Dash Radio and Multimedia Receivers

Your motorhome may be equipped with an infotainment dash radio, and depending on model and options, may include Sirius Satellite receiver (subscription required) and navigation, along with Apple CarPlay compatibility (the radio unit, along with included features installed in your vehicle may differ). Refer to your TMC Owner's Packet or TMC's on-line Owners Resource for dash radio information.

NOTES:

- *The dash radio is typically powered by the auxiliary (coach) battery(ies). This is so it can be used as an entertainment device while the vehicle is parked.*
- *While traveling and while parked, the master battery switch must be ON to power the dash radio, along with navigation and camera monitor features.*



Dash Multimedia Receivers offer entertainment, navigation, hands-free cellphone connectivity and other useful travel enhancements.

Television

NOTICE

The television is attached to an adjustable swing/tilt mounting bracket. Ensure the television mounting bracket is securely stowed and locked before travel.



Typical HDTV with swivel mount

Your motorhome is factory-equipped with a high-definition LED television, which includes HDMI and other media inputs (models and size may vary). Please refer to your TMC Owner's Packet or the on-line TMC Owners Resource for important operational and warranty information associated with your television.

Cable TV Hook-up

Your motorhome may be equipped with a cable TV hook-up, as illustrated below. When supplied, cable hook-ups are typically installed on the driver's side of the motorhome. The cable TV hook-up is designed to receive a standard F-type coax connector, either threaded or push-on style.

Inquire with the park management for cable availability, hook-up, and cable turn-on details.

If you have any questions regarding the fitment and location of your motorhome's cable hookup, please contact TMC Customer Care.

Cable and Over-the-Air TV

Most TMC motorhomes are factory equipped with an external over-the-air television antenna and a cable television input port. Usually, the television antenna is integrated into the WiFi extender.



Typical park-supplied cable TV hook-up is usually located on the driver's side of the motorhome.

Although installations differ in layout, most installations will include:

- A HDMI switching box (may be an optional or not available with some Class B models)
- An antenna/cable switch panel (shown as 'Booster Plate' in the diagrams)
- A 120-volt AC electrical outlet

To view over-the-air (OTA) TV:

1. Locate the antenna/cable switch panel. This panel will have a coax connector on it.

This is the connection point to your TV from either an OTA antenna or a cable TV source.

2. If your TV has a COAX input, connect a COAX cable from your TV to this COAX connector.

NOTE: If your TV does not have a COAX input, you will need to purchase a COAX to HDMI converter box. Connect a COAX cable from the converter box to this wall plate, then connect a HDMI cable from the HDMI converter's OUTPUT to your TV's HDMI INPUT.

3. On this panel is a push-button switch; press this switch until the green LED is ON. An illuminated green LED indicates that the over-the-air TV antenna is connected to the television input. If the LED is OFF, then your TV is connected to the Cable source.

4. Using the TV remote control, locate the menu that allows automatic over-the-air channel scanning; select this option. The television should begin scanning for available over-the-air television signals.
5. Once scanning is complete, use the channel selector on the television remote control to view the available over-the-air channels.

To view cable channels:

1. Locate the antenna/cable switch panel and press the push-button switch until the green LED is OFF. This indicates that the televisions are connected to the cable signal.
2. Using the TV remote control, locate the menu that allows automatic cable channel scanning; select this option. The television should begin scanning for available cable channels.
3. Once scanning is complete, use the channel selector on the television remote control to view the available cable channels.

NOTE: If equipped, turn your TV antenna booster ON while watching local television stations (OTA); turn OFF the TV antenna booster when watching cable or satellite.



Antenna/Cable push-button selection switch with green LED

Wi-Fi Connectivity: 4G System

Your motorhome may be factory-equipped with a Winegard WiFi extender. Designed specifically for the mobile environment, the Connect™ 2.0 is a long-range, high performance WiFi extender that increases the range of existing WiFi hotspots. It maximizes speed and range from both WiFi and 4G LTE networks to keep users connected in all but the most remote areas. The Connect™ 2.0 will also accommodate WiFi calling mode in the absence of cell signal inside the RV.



Winegard® Connect™ 2.0 WiFi and 4G LTE Extender

To become operational, the WiFi extender requires set-up procedures that are unique to each unit. Refer to the manufacturer's set-up and operational guide, provided by the manufacturer and included with your TMC Owner's Packet.

NOTE: Depending on the model, the WiFi Extender installed on your motorhome may not include FM or other OTA antennas.

Contact the manufacturer for technical support:

<https://winegard.com/support>

* Each Connect system comes preloaded with 300 MB of data, and a Winegard SIM card. You will be able to initially connect via Winegard's 4G to set-up an account and buy more data. If you would prefer to use a different 4G/LTE network, the installed SIM card will need to be swapped for a SIM card from your network provider.

Basic Operation

1. With a WiFi enabled device, connect to the Connect system using the factory installed SSID and password printed on the unit's manual. If the original manual is not available, the password is printed on a label attached to the inside of the SIM access panel (located on the base of the rooftop unit).
2. After connected, open your web browser and type **10.11.12.1** and press **ENTER**. This will open the main log-in screen.
3. Type **admin** in both the Username **AND** Password fields. Click the **CONTINUE** button.
4. On the main Status screen, click on either the **4G/LTE** **or** **WiFi** option followed by clicking the **SELECT** button. If the WiFi option was selected, next press the **SCAN FOR WIFI** button.
5. A scan will take place and a list will display all access points that can be detected. Notice the **Security Type** and **Signal Level** and select an available network.
6. Enter the correct password for the chosen network (if required). When the main status page shows connected to that network, you may now use the Internet.
7. If selecting the **4G/LTE** option be sure you have purchased data, otherwise you will be unable to connect to the Nationwide Winegard Network.*
8. On the main Status page, click on the **DATA PLAN** button. To set-up an account or to purchase more data, click on the link in the **SUBSCRIPTION** field.
9. Either click on the **CREATE ACCOUNT** button or Sign-in (if you have previously created an account).
10. Fill out the Account Registration completely and then click the **SAVE** button.
11. Click on one of the available Data Plans and click the **CONTINUE** button.
12. Fill-in the payment information and click the **ORDER NOW** button. This will generate an email with an order number sent to the email on-file. The Connect system will be ready immediately following the Data Plan purchase.

Wi-Fi Connectivity: 5G System

Your motorhome may be factory-equipped with a Winegard Connect™ 5G Router with Wi-Fi Extender. Most units also include over-the-air (OTA) FM radio and broadcast television signal antennas. Designed specifically for the mobile environment, this unit is a long-range, high performance Wi-Fi extender that increases the range of existing Wi-Fi hotspots. It maximizes speed and range from both Wi-Fi and 5G networks to keep users connected in all but the most remote areas. The Connect™ 5G will also accommodate Wi-Fi calling mode in the absence of cell signal inside the RV.

To become operational, the Wi-Fi Extender requires set-up procedures that are unique to each unit. Refer to the manufacturer's set-up and operational guide, provided by the manufacturer and included with your TMC Owner's Packet.



Winegard® Connect™ 5G Router and Wi-Fi Extender

Important Notes

- **DO NOT LOSE YOUR MANUAL;** it contains unique factory default SSID and password information.
- Set-up and operational instructions for the Winegard Connect 5G are not included in this TMC Owner's Manual. Please refer to the manufacturer's instructions, included in your TMC Owner's Packet, for complete setup and operating procedures.
- Read the manufacturer's instructions carefully and completely before attempting to operate this unit.
- Do not paint any portion of the Winegard connect. Painting the housing or other system components could damage the system and will void the warranty.
- When first setting up the Winegard Connect 5G it is recommended to check for software updates once the system is connected to an Internet source. It is also recommended to check for software updates every few months to optimize your unit's performance.

- Service is for North America only and not available in Mexico. Some Winegard FreedomGO Data Plans work in the US only and some work in the US and Canada. Before purchasing a data plan, verify that it will meet your expectations.
- At the time of this writing, the Winegard Connect 5G will work with data plans from AT&T and T-Mobile. Check with Winegard Customer Service for current data plans and availability.
- Instructions for the Winegard Connect 5G are also available through your on-line TMC Owners Resource account, however important SSID and password information is only included with the manufacturer's instructions that were included with your factory-installed unit.
- If you lose your original manual or cannot find your SSID or password, this information is printed on a label located at the base of the Connect rooftop unit, directly inside the SIM card cover plate. Remove the SIM card cover plate's screws and copy the SSID and password. There is also a reset button in this location. Pressing and holding the button for 30 seconds will return the unit to its factory settings.

If for any reason, you experience difficulties with setup or operating your Winegard Connect 5G, please contact the manufacturer for technical support:

Phone: [800-288-8094](tel:800-288-8094)

Email: help@winegard.com

web: <https://www.winegard.com/support>

NOTE: Some TMC Class B motorhomes may be factory-equipped with Winegard Connect 5G prep only. Check with your dealer for installation and data plan details.

DISCLAIMER: Although every effort has been made to ensure that the information provided to you by the manufacturer and TMC is correct and complete, no company shall be held liable for any errors or omissions in the information provided to you in this or the manufacturer's publications. If the Connect 5G antenna installed in your TMC motorhome does not function as expected, please contact Winegard Company.

Interior Furniture

Beds and Bunks

⚠️ WARNING

The sleeping accommodations in this vehicle are designed for occupancy only while the vehicle is NOT in motion. All occupants in this vehicle must be seated at a designated seating position and must always wear seatbelts while this vehicle is in motion. Failure to do so can result in severe injury.

Beds and bunks that convert to passenger seating for travel must be converted fully to upright seating and have the occupant seatbelts properly routed and worn by traveling passengers.

Failure to do so could lead to severe injury or death.

⚠️ WARNING

All swivel seats located in the cab of the vehicle (driver and front passenger) must be in the locked, upright and forward-facing position while the vehicle is in motion and seats are occupied.

Driver, front passenger, and all occupants must always wear seat belts while the vehicle is in motion.

Failure to do so can result in severe injury or death.

The non-cab seating of your motorhome is designed to conveniently convert into bunks and beds. Each floor plan offers unique bed arrangements and conversions.

IMPORTANT! NEVER OCCUPY BEDS OR SEATS IN THE RECLINING POSITION WHILE THE VEHICLE IS IN MOTION.

Conversion of seating to beds varies depending on floor plan and features. Some seating is motorized, which requires that the main battery switch be in the ON position for operation. Be sure that whenever converting seating to beds that fingers and other bodily parts remain away from potential pinch points and that support bars and slats are securely in place.

TMC Class B models offer a wide variety of passenger seating and bed conversions. Bed conversion instructions, along with dinette and other interior details are provided in through the Thor Motor Coach Owners Resource.



Twin bench seats and full-width bed conversion



Motorized bench seat and actuation switch. For some models the rear bench seat is manually operated only.



An example of a typical dinette and bed conversion

Dinette and Work Surface Tables

All floor plans include stowable dining and work-surface tables. Table style varies with floor plan layout and features. Some tabletops are set on removable pedestals, while others are mounted on swing-away or other types of brackets.

BEFORE TRAVEL, ENSURE ALL SURFACE OBJECTS, TABLES, AND RELATED PEDESTALS AND BRACKETS ARE SECURELY STOWED.



Typical examples of dinette and work-surface tables. Type and style dependent on floor plan layout.

Convenience Tables

Included with some floor plans and located just inside the motorhome's sliding door is a convenience table stand and grab handle. The tabletop creates a stow-able work surface, while the base contains electrical outlets for operating electronic devices. Both front driver and passenger seats rotate to the rear and recline, creating a comfortable seating area.

Flip-up convenience table



Opening the table:

1. Grasp the lower edge of the table.
2. Swing the table in an upward arc until the prop rod locks into place. The tabletop will lock in a horizontal position (Figure 1).

Stowing the table:

1. Along the prop rod, locate the lock tab.
2. Lift up the tabletop slightly to relieve pressure on the lock tab.
3. While holding the tabletop, pull the lock tab slightly towards the center of the van, so that the tab releases and allows the top portion of the prop rod to slide downward (Figure 2).
4. Lower the tabletop to its vertical and stowed position.

NOTE: Do not exert excessive pressure or weight on the tabletop.

IMPORTANT! BEFORE TRAVEL, ALWAYS SECURELY STOW CONVENIENCE TABLES AND RETURN SWIVEL SEATING TO THE FORWARD AND UP-RIGHT POSITION.



Figure 1



Figure 2

Convenience tables offered on some models open to the outside.

To open, simply grasp the top edge of the tabletop and pull downward. The tabletop is supported by guy wires and is held in place with a magnetic catch.

NOTE: Some equipment illustrated may be optional or not available.



Lagun® Table System

The versatile Lagun Table System is installed in several TMC Class B models. It provides convenient and adjustable work surface. The system consists of 4 main components:

- Mounting Bracket
- Table Leg
- Table Arm
- Table Mounting Plate

The Mounting Bracket is usually affixed to a vertical surface, such as on the forward side of the bench just to the rear of the driver's seat. The Table Leg slides onto the mounting bracket and is locked in place by turning a locking handle (clockwise to tighten, counter-clockwise to loosen). The upright leg has a slot on its reward side which allows for height adjustment.

The horizontal arm has tightening mechanisms on each end; one slips onto the pin on the top of the upright leg, while the other mechanism is used to receive a similar pin that is affixed to the table mounting plate in which the tabletop is mounted.

Once assembled, the locking mechanisms can be tightened to keep the table from moving, or the mechanisms can be loosened to allow the table to swing freely between seating positions.

Stowing the table and its components accomplished by loosening the locking mechanisms, then separating the components. The Table Leg stows onto slots built-into the table mounting plate, while the table arm is affixed to the pin on the table mounting plate. Turn the locking handles clockwise to secure the components.

Operating Tips:

- The Lagun Table Leg system can swivel, adjust vertically, or be disassembled for storage by loosening/tightening the handles.



Lagun Table System components stowed on the underneath side of the tabletop.

- Loosen handles before connecting, disassembling, swiveling, or adjusting the table height.
- Tighten handles to secure into place.
- All handles tighten clockwise and untighten counter-clockwise. DO NOT overtighten handles as thread damage may occur, causing the handle to seize.
- Each handle has a mechanism that allows for a ratcheting-like movement. Therefore, tightening and loosening can be accomplished in spaces where handle movement is limited.
- Push the button on the handle center post IN while pulling outward on the handle, then spin the handle freely. Reposition the handle on its spline, then continue tightening or untightening the locking mechanism.
- The vertical adjustment is approximately 6 inches up or down.

CAUTION: Be mindful of the limited height adjustment range. Tightening the leg handle when the leg is out of its adjustment range may cause damage to the leg track or the handle to become cross/threaded or seized.

NOTE: This adjustable table, legs, and arm is designed to support up to 40 pounds of weight, including the weight of the tabletop. Damage to the table system can occur if weight loads exceed this amount.

DO NOT SIT, KNEEL, OR STAND ON THE TABLE-TOP OR ITS COMPONENTS.

Storage

⚠ CAUTION

- When traveling, items stowed in overhead cabinets can shift. To avoid injury from falling objects always open overhead cabinet doors cautiously.
- Do not allow children to play within storage compartments. They could become entrapped and suffer severe physical harm.
- It is not recommended to stow items or gear near electrical, heating, or water-system equipment. Ensure all electrical and heating devices are surrounded by free-flowing ventilation.

All TMC Class B Motorhome floor plans are well-designed to include plenty of interior storage. Most floor plans include overhead cabinets, closets, wardrobes, drawers, and under-bunk storage.

When traveling, ensure that all stowed items are secured so that they do not become flying objects during panic stops or sudden vehicular movements. Also, if stowing items in spaces that contain the furnace/water heater, electronic equipment, or other systems devices, ensure that stowed items do not interfere with required free-flowing ventilating space for these devices.

Varying by floor plan and options, TMC Class B motorhomes offer plenty of storage capacity to meet your travel requirements.



Over-cab Storage

There is an over-cab storage bin available, directly above the front driver and passenger seating and visor area of RAM ProMaster-based Class B motorhomes. Only stow light-weight items, such as jackets, blankets, and pillows in this storage bin.



7

INTERIOR FEATURES AND COMPONENTS

Lockable Storage Compartment

Some TMC Class B models offer a lockable storage compartment located to the rear of the camper-van. This area provides a secure location for tools and other valuables.

Affixed to the left and right sides of the storage compartment are adjustable securing rings which provide securing attachment points for cargo.

With the rear bunk is stowed, as in the illustration below, the rear area of the camper-van can accept larger items for transport.



Illustrated in these two photographs is the rear view of the TMC Sanctuary/Tranquility 19M.



Skylight

⚠ CAUTION

The skylight is **NOT** designed to be an emergency escape hatch.

Select Class B models feature a large, easy-to-open skylight. The skylight is opened by pulling and rotating the bar-lever. Returning the lever to its stowed position will close and latch the window.

Opening the skylight:

1. While pressing the latch-lock, pull the bar-lever in a downward direction (Figure 1).
2. Continue to rotate the bar-lever in a downward and backward arc, which opens the skylight (Figure 2).
3. Place the bar-lever end in a fully open or in one of the partially open positions (Figure 3).

Closing the skylight:

Move the bar-lever in a downward arc, then upward until past the lock-latch.

Sunshade:

The Skylight has a built-in sunshade. To close, simply pull the shade across the opening.



Figure 1



Figure 2



Figure 3



Skylight and built-in sun shade



Built-in sunshade

SkyBunk® (optional)

⚠ CAUTION

- **NEVER DRIVE THE VEHICLE WITH THE TOP RAISED.**
- **NEVER OCCUPY THE BUNK AREA DURING TRAVEL OR ANYTIME THE VEHICLE IS IN MOTION.**
- **ONLY** open the SkyBunk top when the vehicle is parked on solid and level ground. Always close the SkyBunk top before moving the vehicle.
- Before opening the top, ensure there are no low-hanging branches, wires, or other items that would interfere with an opened top.
- **DO NOT** raise the top in weather conditions with winds or expected winds of 25 MPH or greater. Severe damage to the canvas, lift mechanism, and top is possible.
- Elevated beds can present a fall hazard which may result in severe injury.
- **DO NOT** allow adults, children, or pets in the bunk area if the top is not in the fully open position.
- The sleeping and lounging area is accessed via a ladder. Never exceed the weight limits of the ladder and sleeping/lounging area.
- Ensure the ladder tabs are securely inserted into the ladder brackets before climbing onto the ladder.
- Using entry and exit devices other than the access ladder could result in a fall or severe injury.

⚠ CAUTION

- Failure to comply with the load capacity of the access ladder could result in severe injury.
- This bunk area should never be occupied by more than two people at a time.
- This bunk area is not factory-equipped with safety netting or safety rails. Use extreme caution when children occupy this area. Installing safety netting is strongly advised.
- Moving parts of the lift mechanism could cause severe pinch, crush, or cut injuries. Keep hands, fingers and body parts away from moving mechanisms.
- Always use the locking clamps and mechanisms to secure the top before moving the vehicle.
- When lowering the top, inspect to ensure the canvas material is completely contained inside the closed top and that the canvas material is not caught in the lifting mechanisms or interferes with the top seals.
- **DO NOT** drive the vehicle at speeds in excess of 80 MPH. Damage to the top or the vehicle is possible.

Providing additional sleeping and lounging space, the SkyBunk is available on select models of TMC Class B motorhomes. The top is constructed of durable GRP material and is lined to provide excellent thermal insulation and soundproofing qualities.

The roof can be easily raised and lowered, by its scissor lift mechanism. For comfort, the SkyBunk includes a full-sized mattress with spring support. The high-quality side fabric is flame-retardant and includes front and side windows which have zippered covers and fly screens. The front window can be fully zipped-open, offering an unencumbered view and emergency escape path.

A folding mechanism automatically pulls the fabric inward when the roof top is closed; keeping the fabric from getting caught between the bodywork and the top.

Adding to the Skybunk's convenience features are USB power/charging ports and LED reading lamps.



Inside view of the bunk area

NOTE: Before raising the SkyBunk, ensure there is adequate space above the vehicle to fully raise the top.

Before Raising the Top

1. Park the van on a level area.
2. Engage the parking brake.
3. Ensure there is adequate space above the vehicle to fully raise the top.
4. Check the weather; do not open the top if wind speeds or expected wind speeds exceed 25 MPH (40 KPH).



SkyBunk®

Raising the Top

1. From the inside, release the buckles on the two safety straps (Figure A) by pressing on both sides of the clip and separating the two parts (Figure B).
2. Unfold and attach the ladder, engaging the hooks into the brackets, rotate the tabs and lock in place (Figures C-D-E).
3. Locate the push-button latch (Figure F). Insert and turn the key, then press the button to release the lock mechanism. It may help to pull down on one of the handles while un-latching lock mechanism (Figure G).
4. After unlocking and releasing the latch, grab both handles and push the top upwards until it is fully extended. You may need to climb the ladder a few more rungs.

Opening the Side and Front Windows

Windows located in the front and side canvas can be opened for ventilation:

1. Locate the zipper and unzip the window covering.
2. Roll up the unzipped covering and secure with the straps located at the base of the window (Figure H).

Fig. E: Ladder locked in bracket



Folding Ladder



Figure F: Push-button latch mechanism with keyed lock



Figure A: Safety buckle



Figure B: Safety buckle



Figure G: Handle an convenient pull-down straps



Figure H: Window strap and hook



Fig. C: Ladder hook



Fig. D: Ladder lock





SkyBunks may include USB charging ports and LED reading lamps



Ladder access to SkyBunk

Lowering the Top

NOTICE

Ensure the soft sides of the top are dry before closing.

If it is necessary to close the top while the sides are still wet, open the top at your earliest convenience to allow the sides to air-dry.

1. Ensure all bedding, clothing, and devices are removed from the bunk area. The mattress can remain in the bunk area.
2. Zip the screens and window openings closed.
3. Pull down equally on both left-side and right-side handles. If you cannot reach the pull-down handles,

carefully ascend the ladder in order to reach the handles. Detachable straps are provided to aid this process.

4. As you pull the top closed, the soft sides should automatically fold-inward. Ensure that the fabric is not pinched or become entangled in the support arms and latching mechanism.
5. Before pulling the top completely closed, walk around the outside of the van and observe the top to ensure the fabric is tucked inside the top and that the seals are clear of fabric material.
6. With the fabric tucked inside the top, pull down on both handles until the latch mechanism catches.
7. **IMPORTANT! Check that the latching mechanism is secure by grabbing both handles and push upwards.**
 - a. If upward pressure on the top does not change its position, then the latching mechanism is secure.
 - b. If the top moves upward, the latching mechanism is not securely engaged. Open the top slightly and look for and move any fabric or item that is hindering the top from closing and latching properly. Then, pull down firmly on the handles and ensure the latch mechanism is securely engaged.
8. Latch both side safety buckles.

NOTE: It may be necessary to tuck and roll the side fabric towards the outside edges of the closed top in order to engage the safety buckles.

Tips for Safe Use

- Please use sound judgment when allowing children to sleep in this elevated bed. Generally, it is not advisable for children to sleep or occupy an elevated bed or bed loft area.
- Discuss proper use of this elevated bed area with children and make sure they are supervised when occupying this bunk area. Do not allow horseplay in this elevated bunk area.
- Provide a safe (low voltage, battery-powered) night light in this elevated sleeping area so occupants can see at night when getting in and out of this bunk area.
- No more than two people should occupy this bunk area at any given time. Make sure all weight restrictions posted on or near this bunk and on the access ladder are strictly followed.
- Ensure the top is fully raised before occupying this bunk area. No person or pet should be in the bunk area when the top is being lowered.

Canvas Care

IMPORTANT! THE FABRIC MUST BE COMPLETELY DRY BEFORE STORAGE! STORING A WET OR DAMP SKYBUNK, EVEN FOR A SHORT TIME, CAN CAUSE IRREPARABLE DAMAGE TO THE FABRIC AND VOID THE WARRANTY.

Cleaning tips:

- Always clean the canvas by hand; DO NOT use power washers.
- Use only clean cold or warm water.
- Do not use harsh detergents or cleaning chemicals.
- Test all cleaning products prior to use by applying a small amount to an inconspicuous area.

Cleaning the canvas:

1. Hose down with water and gently wipe with a cloth. Soaps and detergents can damage the water-repellent treatment of the canvas. However, it may be necessary to use mild and diluted detergents, along with gentle scrubbing with a soft-bristle brush, for some soiled areas.
2. Rinse the canvas of any soap or detergent residue.
3. Clean the seals and latch area of dirt and debris.
4. Allow the canvas to completely dry before closing the top.

Care and maintenance:

- Do not spray insecticides or bug repellent directly on the canvas. This may damage the water-repellent treatment.
- For long-term storage, store in a cool dry location that is not exposed to direct sunlight.
- The SkyBunk is made with quality zippers. To prolong zipper life, do not “grind” zippers around corners. If needed pull the canvas, windows, or doors to help zippers glide smoothly. Keep zippers clean and dirt-free.
- The canvas on your SkyBunk has a special Hydra-Shield™ treatment that is watertight yet breathable. You should rarely, if ever need to retreat the canvas. If you do need to spot treat the canvas for water repellency, use a silicone-based repellent such as Camp Dry® by Kiwi®. Other treatments will clog the tiny holes in the canvas eliminating its breathability.
- Seams may also need occasional treatment with a canvas seam sealer.

Cleaning the external fiberglass surface:

- Use a small amount of mild detergent, suitable for fiberglass and automotive painted surfaces.
- When using a power sprayer, make sure to use a weak jet-stream of clean water.
- Gently scrub stubborn soiled areas with a soft, wet sponge. Rinse the sponge often to remove embedded dirt and sand particles.
- Rinse the surface thoroughly with clean water.
- Dry with a soft cloth to prevent water spots.
- Occasional treatments with an automotive wax may be used, as long as the wax compound is compatible with fiberglass surfaces.

Cleaning the inside top surface:

- Use clean, warm water, a mild detergent, and a soft cloth to gently wipe down the inside surface. Stains may need special attention and treatments. When using harsher cleaning products, always test a small area for surface compatibility.
- Rinse with a clean, soft cloth dampened with warm water.
- Allow the surface to completely dry before closing the top.

Safety Nets

CAUTION

Be certain that safety nets or bed rails do not interfere with an emergency evacuation of the motorhome.

Safety nets are not provided by TMC or the SkyBunk manufacturer. Determine if a safety net system is necessary based on your intended use and the age of the occupants. There are numerous safety net styles and designs commercially available. Talk with your dealer about suitable safety net systems and installation procedures.

When installing a safety net, make sure you follow the manufacturer’s installation instructions carefully. Be certain that the safety net can be stowed in a manner as not to interfere with the operation of the top. Also be sure that the safety net does not make contact with the soft sides of the SkyBunk. Damage to the fabric could occur.

This page is intentionally blank

Introduction

TMC Class B motorhomes are equipped with Rapid Camp+® multiplex wiring systems sourced from Firefly Integrations and BPro. A multiplex system uses low-voltage, digital signals to control the electrical and electro-mechanical devices within your motorhome via an intuitive, user-friendly touchscreen control panel. Control functions are model and floor plan specific, depending upon the standard and optional features available. In typical configurations, a multiplex system will allow the user to monitor and operate these features from the main touchscreen panel:

- Lighting and fan controls
- Climate (HVAC) controls
- Holding tank and LP level monitoring
- Water heater, water pump, and heat pads on/off
- Electrical system monitoring
- Battery energy monitoring
- Inverter settings and controls
- Generator on/off
- Shore power fault indicator
- Solar charging system monitoring and settings
- Remote smartphone or tablet control via app

Although each motorhome model and floor plan will have its unique system design and features, in its standard form, the multiplex wiring system consists of:



Typical Firefly Integrations multiplex main control panel. Features vary depending upon model and floor plan.



BPro RVDM50 Control/Display

- Centrally located multi-function control panel
- Power management module (PPM)
- Individual wireless room switch panels

Careful attention has been designed into the system to make operation simple and user friendly. On the main touchscreen panel, the function of each control button is clearly displayed, appropriately sized, and logically placed. Individual wireless switch panels may be conveniently located within the motorhome. Each control button on the wireless switch panels is evenly backlit by LED illumination to provide feedback to the operator of the status of each function.

Both manufacturers offer product manuals, helpful How-to guides, and videos from their websites. If you have questions about your multiplex system, a few moments visiting these sites may give you the answer you need. Both manufacturers also provide technical support services, usually accessible by email, for more in depth help.

<http://www.fireflyintegrations.com>

<https://teambmpro.com>

NOTE: A multiplex wiring system is defined as an RV-C (a standardized communications protocol) network consisting of a main control panel with one or more remote switch panels. When a switch (or control function icon) is pressed, a signal is sent to a controller, which sends 12-volt power to a device to activate it. The RV-C network communicates with motorhome components and automates their function.

Multiplex system information and images courtesy of BPro and Firefly Integrations.

Control Panels

There are two styles of touchscreen panels installed in TMC Class B motorhomes. The control panel of the Firefly system is a true touch-screen. Selecting menus, sub-menus, and control features is accomplished by lightly pressing on a screen icon or soft-switch. The control panel for the BMPPro multiplex system uses an LDC display screen to show the operator menus and control features. Selection is accomplished by pressing appropriate buttons around the periphery of the LCD display screen. Although styling and features vary, all control panels are designed to be intuitive and easy to use.

Below are illustrations of the Firefly Lyra touchscreen control panel and BMPPro's RVD50 Controller. Although the user interface is different, both systems allow similar RV systems management from a centrally-located, easy to use panel. Both systems allow for remote systems control via a Bluetooth-connected smartphone or tablet.



TMC Class B Camper Vans are equipped with either Firefly's Lyra touchscreen control panel or BMPPro's RVD50 Control/Display.

Control and monitoring features not included on the RVD50 LDC display panel can be accessed via the BMPPro RVMaster App for iOS or Android smartphones.

Wireless Switch Panels

Multiplex systems installed in TMC Class B motorhomes may use wireless switch panels, which are conveniently located to allow remote control many of the functions found on the main touchscreen panel. Control functions vary from switch panel to switch panel. Some may control room lights and fans, while others may control awnings, water heaters, or generators.

On the face of each switch panel are control icons that represent the function of the switch. Each control icon has a LED backlight to indicate whether the function is on or off. Depending on the control function, the switches may be momentary (press once for ON, press again for OFF), while other functions may require the user to press-and-hold for the function to operate correctly. Lights that are dimmable will have Up/Down arrows next to the icon. Press and hold these buttons to ramp the brightness up and down. Each time a button is pressed, the green operational LED will illuminate to indicate that the command has been sent to the system's controller.

The switch panels are powered by a single coin-cell battery (#2032). If, when pressing a switch panel button, the green LED does not illuminate, the battery will need to be replaced (see note).

You can check battery status for Firefly wireless switch panels by clicking on the settings button on the multiplex main touchscreen panel, then navigating to the Wireless Switches screen.



Typical Firefly wireless switch panel.



NOTE: To access the battery, pry the switch from the wall mounting cradle to expose the battery compartment on the rear of the switch and replace the #2032 coin-cell battery.

See page 86 for BMPPro remote switch information.

BMPPro Remote Switch Panel

Main Electrical Control Boards

A multiplex wiring control system will include a main electrical panel. Some systems refer this panel as the master node or some other terminology. The main electrical panel is the power distribution center for the motorhome. The panel receives signals sent from the main touchscreen and remote switch panels and performs the actions that have been requested by activating and deactivating the associated circuits.

The main panel will include low-voltage control connections to the individual electrical circuits that are controlled by the system. The main panel is then remotely connected to the user interface, or main touchscreen panel, where the user makes device control selections. In some multiplex systems, the connection from the main electrical panel to the user's touchscreen is by Bluetooth pairing, but it could also be a wired connection.



Firefly Integrations system control board



BMPRO MasterNode main system control board



Wiring illustration (above) of a typical Firefly multiplex system; consisting of main touchscreen control panel, wireless room switches, and main electrical control board.

Basic Multiplex Operation

NOTICE

Multiplex system manufacturers offer regular software and system updates, usually through an on-line link accessed through a Wi-Fi connection.

Contact TMC's Customer Care or refer to your multiplex system manufacturer's instruction manual for information pertaining to multiplex system updates.

NOTICE

During very cold or very hot weather conditions, the image on touchscreen control panels (radio, multiplex, and other liquid crystal display (LCD) panels) may appear unclear or react slowly. Once the interior temperature of the motorhome stabilizes, normal LCD panel display and operations will resume.

Complete multiplex system operational instructions are not included in this manual. The instructions that are included in this manual are designed to give you basic system operation so that you can begin to navigate and use the multiplex system installed in your Class B camper-van. For detailed multiplex system instructions, please refer to the manufacturer's instructional manuals and other electrical systems information available in your owner's packet, the multiplex manufacturer's website, or through your TMC Owners Resource on-line document service. There, you will find documents and instructional videos covering important operational and safety information pertaining to the multiplex system installed in your motorhome.

<https://www.thormotorcoach.com/owners/>

The multiplex system installed in your TMC motorhome is designed to be intuitive and easy to operate. Basic operation involves these steps:

1. Ensure DC power is ON to the motorhome; either from the auxiliary battery(ies) (by turning ON the master battery switch), or through a 120-volts AC source (shore power or generator, which provides DC to the motorhome via the converter or inverter).
2. With a power source activated, locate the main touchscreen panel. Some touchscreen panels will automatically 'turn on' or 'light up' when power is present, while other panels may require the user to press a button on the panel or touch the central display.
3. From the menu selections, navigate to the feature you want to control. Some panels will have menu and other selection buttons around a central display screen while

other systems will have menu icons and control features displayed on a touch-screen panel.

4. With the feature menu selected, simply operate the control for the desired effect. For example, turn on or off the lights, raise or lower the temperature, turn on or turn off the generator, or operate an awning.

NOTE: Some control functions require a simple press-and-release of finger pressure on a switch or control icon, while others may require a press-and-hold until the desired function completes an actuating cycle.

5. Return to the main menu by either pressing the HOME icon, or on some touchscreen panels, press a return arrow.

NOTE: Some multiplex functions have ignition lockouts or other safety-related pre-conditions that prevent operation until it is safe to operate the function. If a function is locked out, a screen message will either indicate a problem exists or provide a reminder to perform a safety check before proceeding with control operations.

Remote Control

The multiplex system installed in your motorhome allows for remote control via a smartphone or tablet app. Some systems allow for remote control via a Bluetooth pairing, while other systems may connect remotely via a Wi-Fi signal. It is highly recommended that owners take advantage of this useful feature, for it gives the user operational control of the motorhome's features in the palm of the user's hand.

Additional Multiplex Systems Information

Complete multiplex systems details and operational instructions are described in the manufacturer's owner's manuals and TMC's Multiplex Systems Guides available through your TMC Owners Resource on-line account:

www.thormotorcoach.com/owners

Multiplex systems how-to videos are linked through your TMC Owners Resource account and are also available on TMC's YouTube site:

www.youtube.com/user/ThorMotorCoach

Firefly Screen Navigation

Tap any icon from the Home Screen, to select the desired Sub-Menu. The main battery switch must be ON to power and operate the multiplex touchscreen controller.

NOTE: For complete Firefly Multiplex System operational instructions, refer to the Firefly instruction manual available through your TMC on-line Owners Resource account.



- 1 **HOME:** The Home Menu Screen is the main access area for all the multiplex system sub-menus. It also displays the air conditioner temperature settings, a clock, date, auxiliary battery condition, a shore power fault warning and access to a system search function.
- 2 **LIGHTING:** Menu controls lighting for the entire motorhome; light circuits on, off, or dimmed. Any lighting circuit setting made on the Lights Menu are linked to and turned ON or OFF by the Light Master Switch.
- 3 **ELECTRIC:** Menu displays auxiliary and chassis battery condition and Solar Charge Controller settings.
- 4 **CLIMATE:** Menu allows control of furnace and air conditioner (front and rear) temperature settings.
- 5 **DIAGNOSTICS:** Menu and sub-menus allows the monitoring of all electrical circuits and indicates electrical faults.
- 6 **SETTINGS:** Menu and sub-menus allow for customization of display screens, connection to the multiplex mobile app, and other system features.
- 7 **WATER SYSTEM:** Soft switches allow control of the water pump (ON/OFF) and Holding Tank Heaters (ON/OFF).
- 8 **HOLDING TANK MONITOR:** The display gives a visual indication of the percent from empty to full in 1/3 increments of the holding tanks and LP tank. NOTE: Cassette toilet is not monitored.
- 9 **FANS AND LIGHT MASTER:** Soft switches allow control of the ceiling fan and lighting master (depending on the Lighting Menu selection).
- 10 **AWNING:** Soft switches allow for the extension and retraction of the camp-side awning. If installed, soft switches also control awning and exterior lighting.

Firefly Phone App

Your Firefly Multiplex System can be remotely controlled via a smartphone app. The system uses either an Eclipse or Mira Vegatouch wireless interface module. These modules easily connect to any Android or iOS device to give total control to many electrical, electronic, and mechanical systems installed in your motorhome. All is need is to download the Eclipse or Mira Mobile App to your phone, then pair your phone to the interface module.

Vegatouch Mira: The Mira interface allows remote control of motorhome functions from roughly a 90-foot radius of the motorhome.

Vegatouch Eclipse: The Eclipse interface allows the same 90-foot radius control as the Mira, but also includes the option to access control functions from an Internet connection, therefore remote control can be accomplished virtually from anywhere.

NOTE: If your Firefly Multiplex Touchscreen is displaying the wrong wireless remote module, press and hold the Vegatouch icon for 7 seconds. Doing so will switch between Mira and Eclipse modules.

Vegatouch Mira and Eclipse Setup

NOTE: Make sure that Bluetooth is turned ON in your smartphone or tablet settings menu before proceeding with Vegatouch setup.

1. **Locate the Login Information.** The Login information Screen (illustrated below) can be located from the Firefly SETTINGS MENU (Figure 1).

Tap to enter Vega-touchscreen

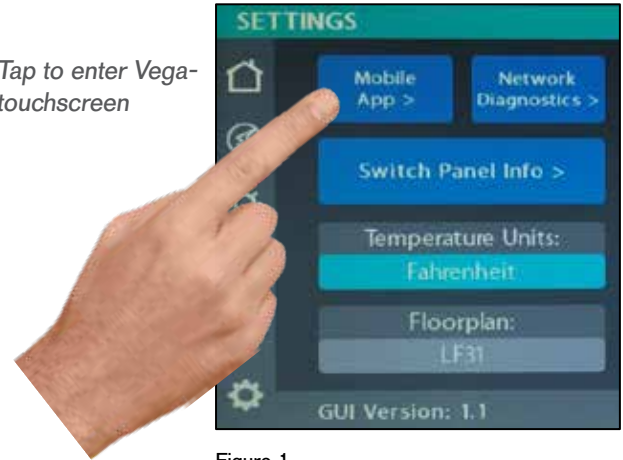

Figure 1



Illustration of the Mira or Eclipse Login Interface Screen

2. Download: Locate and Download the Vegatouch Mira/Eclipse App from the Google Play or App Store. Once download is complete, install the app and open it.

3. Setup:

- › Tap SCAN to find the Mira/Eclipse Module's Bluetooth signal. After scanning, any interface module in your Bluetooth range will appear on the screen (Fig. 1).
- › Tap the ID number that matches the one on your Vegatouch Module. Enter the Default PIN number (777777) (Fig. 2).
- › Then press AUTHENTICATE to connect to the Vegatouch module (Fig. 3).



Vegatouch Module

iOS Setup Tips:

Turn ON Bluetooth to allow Vegatouch Mira/Eclipse to connect to Accessories.

If you do not have Bluetooth turned ON in your iOS Settings, you will see this screen on your device: Do not click OK; you MUST click SETTINGS. Your Bluetooth Settings page will now appear and you should turn Bluetooth ON.



Figure 1



Figure 2



Figure 3



Location Services Required:

To enable Location Services on your Apple device:

1. Go to SETTINGS/PRIVACY/LOCATION Services.
2. Make sure that Location Services is ON.
3. Scroll down to find your app.
4. Tap the app and select "Always allow access to your location."

Android Setup Tips:

Allow Vegatouch Mira/Eclipse to access this device's location.

Mira will need to be allowed access to your location. Click ALLOW when you see this screen.

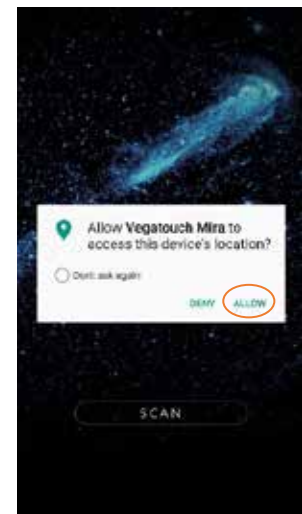

8

MULTIPLEX SYSTEM

To enable Location Services on your Android device:

1. Open your phone's Settings app.
2. Tap Location/App Permission
 - › If you don't see 'Location', tap SECURITY & LOCATION/LOCATION.
 - › If you have a work profile, tap ADVANCED/LOCATION.
3. Under 'Allowed all the time' and 'Allowed only while in use,' view the apps that can use your phone's location, tap it, then choose the location access for the app.
4. To change the App's permissions, tap it, then choose the location access for the app.

App Settings:

Access the App Settings page (on your phone) by tapping the triangle at the bottom of the screen, to expose the Settings Button. Tap the gear icon to go to the app's Settings page.

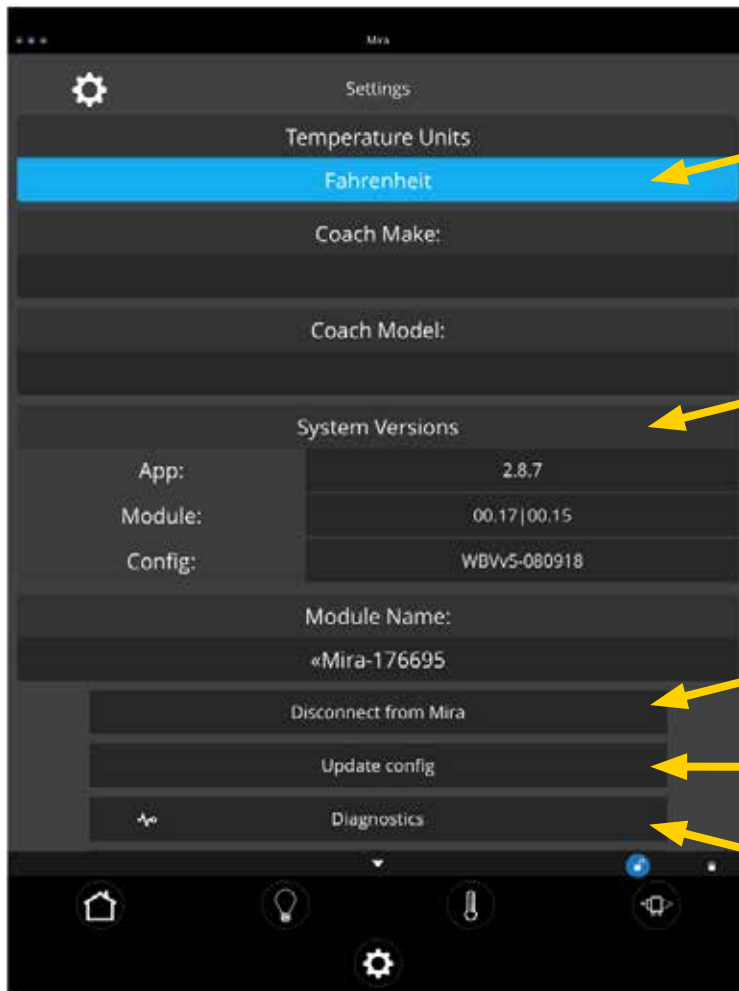

Tap the Temperature Units selection to choose between Fahrenheit and Celsius.

System Information and module Name.

Tap to disconnect your device from the Module.

Tapping Update Config will force a download of the config from the cloud.

Tap to enter the Diagnostic Tools Screen

Vegatouch Phone App Settings Screen

Firefly Diagnostic Tools

Remote Help:

If instructed by Firefly, on your Vegatouch Phone App, tap Enable Remote Help for advanced technical support. Once enabled, provide the Session ID to allow Firefly to remotely connect to your app (Internet connection required).

To disable Remote Help, simply tap the Session ID Number from the HOME PAGE of your app.

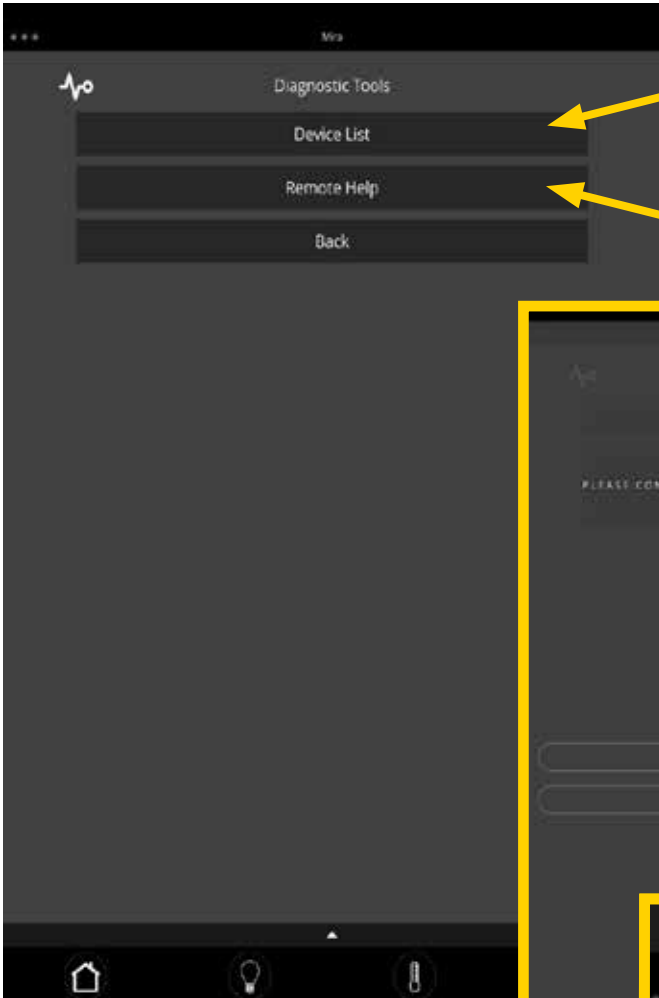

Tap to display a list of currently connected devices.

Remote Help is available by calling Firefly Integrations. Do not enable remote help without consultation from Firefly.

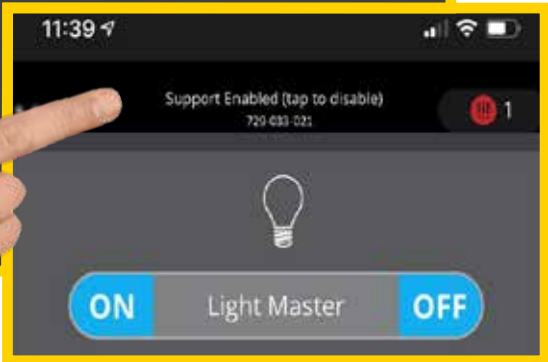
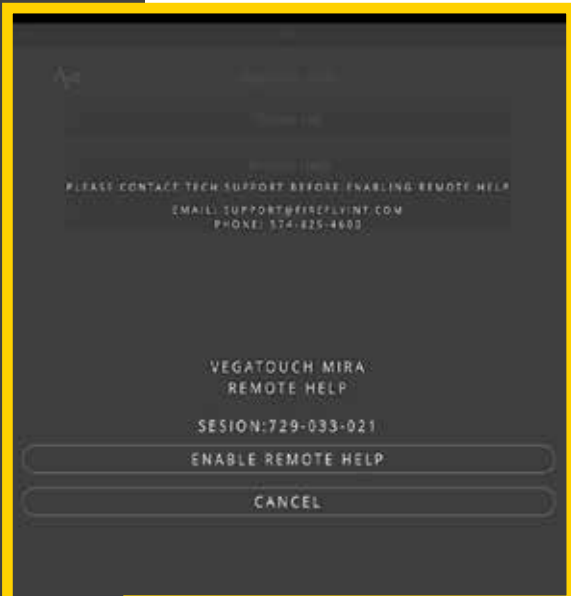

Tap on Session ID Number to disable Remote Help.

Description of BMPro RVDM50 Control/Display



The wall-mounted RVDM50 Control/Display gives you the ability to monitor and control several RV functions:

- Lights (up to 3 circuits)
- Awning
- Water Pump
- Air conditioner
- Tank Monitor in 1/3 increments
- Generator ON/OFF (if equipped)
- Device Paring (smartphone and wireless switches)

- 1 PAGE NAVIGATION BUTTON:** Move between function screens, e.g., from Tanks to Water Screen.
- 2 MENU NAVIGATION BUTTON:** Navigate between items within a page, e.g., in the Water Page move from Pump to Tank Heater.
- 3 ACTION BUTTONS:** The function for each of the action buttons changes depending on the selected menu item. These functions will be displayed on the screen, e.g., OK, EXT, RET, ON, OFF.
- 4**
- 5 REDUNDANCY BUTTONS:** Turn lights and water pump on or off. The climate button takes you to the Main Climate Page. Actual functions may differ from this illustration.

Display Navigation:

1. Use the Page Navigation Button (1) to move from screen page to screen page.
2. Use the Menu Navigation button (2) to move between menu items within a page.

Adjusting the Lights:

- A QUICK Press of light switches 1, 2, or 3 toggles between OFF and the previous stored brightness.
- A LONG Press of light switches 1, 2, or 3 sets the light brightness to 100 percent.

Rapid Camp+® System Diagram

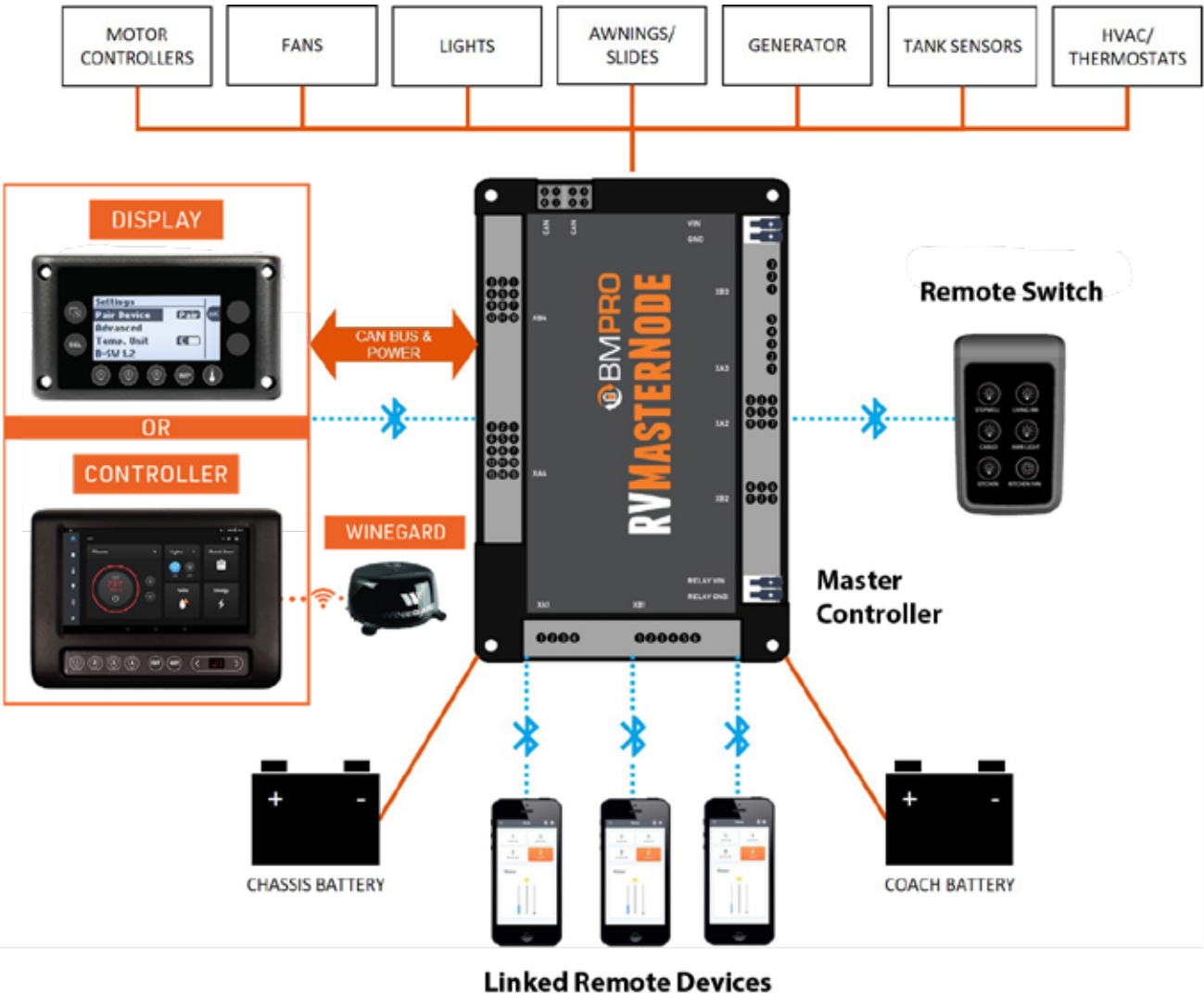

⚠ CAUTION

- Clean the housing of this product lightly with a dry or moist cotton cloth. Do not use alcohol, thinners, benzene or any other chemical cleaner.
- The Rapid Camp+ is a high precision electronic device. It contains no user-serviceable parts inside. Do not try to dismantle, modify, or repair it yourself. Disassembly, service, or repair by an unauthorized person will void the warranty.
- Product specifications are subject to change and improve without notice.



This illustration shows a typical Rapid Camp+ system layout. The Touchscreen Control Panel is Bluetooth linked to the Master Node, which in-turn controls the electrical devices of the motorhome.

Basic Operation:

- Use the Page Navigation Button  to move from page to page.
- Use the Menu Navigation Button  to move between menu items within a page.

Tanks

The Tanks display shows the levels of fresh, gray, and black water withing the corresponding tank. Levels are displayed as:

- Full
- 2/3 Full
- 1/3 Full
- Empty



Motor

The Motor Screen controls the awning. Press the corresponding ACTION Button to EXTEND or RETRACT the awning. Pressing the ACTION Button again while the awning is in motion will stop the awning at a desired position.

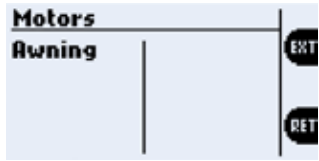

Climate

The Climate Screen controls the air-conditioner. Heating is controlled by a separate Furnace/Water Heater controller.

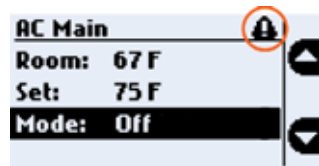

Room: The ambient room temperature.

Set: User-controlled temperature setting.

Range: 33° F - 90° F (1° C - 32° C)

Modes: Off/Fan/Cool/Auto-cool

Fan: Settings for High/Low

NOTE: A Warning Triangle in the upper right of the display screen indicates a fault with one of the climate outputs or the temperature sensor (if installed). A sensor fault is also indicated by an absence of a room temperature indication, e.g., --F.

Water

From the Water Screen, the water pump and other water-related features can be turned ON or OFF.

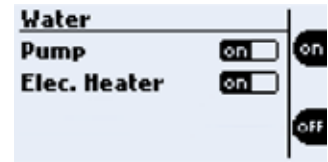

Energy (if equipped)

ON: Press and hold the ON action button, until the generator turns on.

OFF: Press and hold the OFF action button, until the generator turns off.



NOTE: A generator warning will appear if the generator fault LED is actively blinking.

Settings

Pair Device: Press OK to pair to a device.

Advanced: Press OK to go to the Advanced menu.

Temp. Unit: Toggle between Fahrenheit and Celsius.

D-SW: Indicates the software version on the Display.

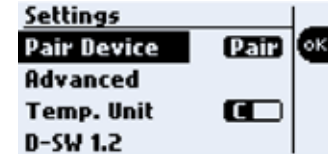

Advanced

Forget All Dv: Unpair ALL Bluetooth Devices.

Pair Switch: Pair Bluetooth Switches.

Forget All Sw: Unpair all Bluetooth Switches.

SW: Node software version.



The RVMaster Smartphone App

NOTE: Available features on the App may vary depending on your motorhome's model and available features.

The RVMaster App is software that communicates control signals to the RVMaster Node. The RVMaster App can be installed onto your personal smartphone or tablet, allowing either Bluetooth-paired control of the RVMaster Node or control via Wi-Fi. When installed and paired to the RVMaster Node, the RVMaster smartphone app allows access to more features of the BMPro multiplex system that otherwise may not be available through the RVD50 controller.

Download the RVMaster app and enjoy the freedom to monitor and operate your motorhome's on-board features and accessories, on-the-move, from your own smartphone or tablet.

Compatible Devices:

The RVMaster App is compatible with Android 8.0 or later and iOS 11 or later. Depending on your device, point your QR Code reader to one of the codes below to download and install the RVMaster App.

NOTE: Available features on the App may vary depending on your RV model. Below are QR code links to the RVMaster App downloads.



Connecting to the Internet:

The Controller has Wi-Fi capabilities to connect to the Internet and download the latest app updates.

Updating the Controller:

To automatically receive the latest updates for the RVMaster App, connect the Controller to the Internet and log in to your Google account. You can also get the latest updates direct from the Google Play Store. Search for RVMaster in the Google Play Store and press Update.

NOTE: For more information, see the BMPro Operational Guide available through your TMC Owners Resource account.

Pairing to the RVMaster Node:

Pairing your smartphone to the RVMaster Node is easily accomplished. The RVMaster Node can be paired to a total of three phones or tablets (see diagram on page 83).

1. Launch the App on your phone or tablet and choose the device installed in your motorhome.



2. Press the Page Navigation Button to navigate to the Settings page.
3. When 'Pair Device' is highlighted, press the OK function button and your smartphone or tablet will begin pairing to the RVMaster Node.



4. If pairing is successful, you will see the Bluetooth icon displayed on the App Home Screen of your smartphone.

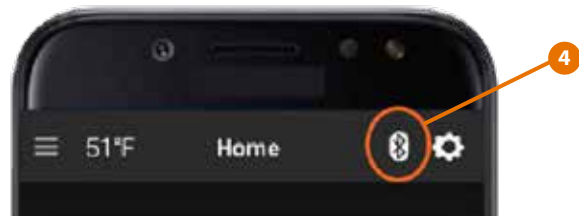

Pairing a Wireless Switch to the RVMaster Node

You may find that a wireless wall switch becomes ineffective in controlling the function it is designed to do. This may happen if the internal battery requires replacing or for some other reason that pairing to the RVMaster Node has been lost.

1. Using the Page Navigation button, navigate to the SETTINGS menu.
2. Using the Menu Navigation button, navigate to the ADVANCED selection.
3. Within the ADVANCED menu, again use the Menu Navigation button to navigate to the PAIR SWITCH selection.
4. Press the ACTION Button next to OK to put the RVMaster Node into SWITCH PAIRING mode.
5. While in PAIRING mode, PRESS any two buttons at the same time on the wireless switch you want to pair.



Configuring the Motorhome Using a Smartphone

You may find that certain functions that were once available are no longer functional from your smartphone. This may be caused by the RVMaster Node or the RVMaster App being inadvertently re-set to a different model or floor plan than your motorhome. You will need to confirm that the RVMaster Node and your RVMaster App are set to the correct model and floor plan of your motorhome.

1. To begin, you will need to know the model, floor plan, and serial number designation of your Class B motorhome. Example: BT18G-25 (BT is the two-digit code for TMC Scope; 18G for floor plan; 25 is the model year).
The TMC Serial Number for your motorhome is located on a label affixed to the driver's side door jamb.
2. Launch the RVMaster App on your smartphone.
3. Press the SETTINGS button to go to the Settings page
4. Press the GENERAL Settings bar 5-times to go to the RV Configuration page.

5. From the RV Configuration page, select your vendor (Thor Motor Coach).
6. Select the model of your motorhome from the listed models.
7. Press NEXT.
8. Select the Model Year of your motorhome.
9. Press NEXT.
10. Select the Floor plan of your motorhome.
11. Press NEXT.
12. Select any optional factory-installed features of your motorhome.
13. Press NEXT.
14. Type the motorhome's Serial Number. NOTE: TMC serial numbers are usually 14 characters long and begin with the two-digit model code of your motorhome.
15. Press CONFIRM.
16. The RVMaster App will restart and the new configuration will be displayed.

Faults and Warnings on the RVMD50 Display

The Display will show warnings of certain issues are detected.

Gas Heater:

A warning will appear if the gas heater fails to ignite after three attempts.

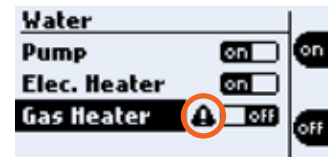

AC Main:

A warning will appear if there is a fault with one of the climate outputs or the temperature sensor. A sensor fault is also indicated by no room temperature value being displayed, eg. --F.

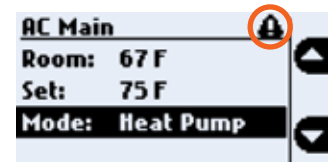

Energy:

A warning will appear if the generator fault LED is actively blinking.

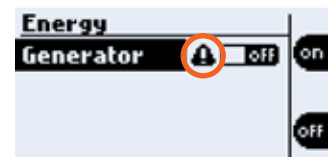

BMPRO Cloud

CAUTION

Keep your password in a safe place and only share details with others if you want them to access and control your motorhome!

Cloud control allows you to remotely connect, monitor and control your RV from your smart device.

Connecting to the BMPRO Cloud:

To connect to the BMPRO Cloud for the first time:

1. Connect your Controller to the Internet via Wi-Fi.
2. Launch the RVMaster App.
3. From the App Home Screen, press the Settings  icon.
4. Press Remote Connection.
5. Press Create account.

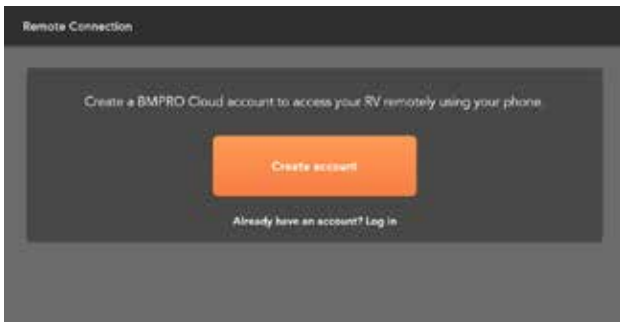

6. Enter your full name, email address and a password of your choice.
7. Press Create account.

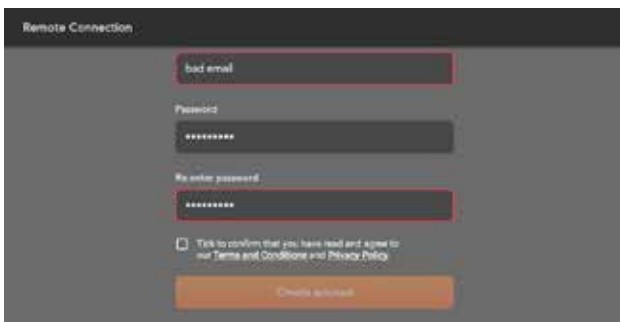

8. An email will be sent to your account to verify your email address. Click on the link provided in the email to complete verification.
9. Now connect your smart device using your BMPRO account details to get started.

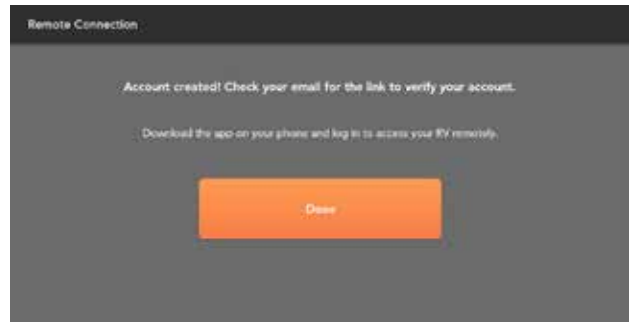

Account Not Verified:

If the email address was not verified, a message will appear.

Press RESEND VERIFICATION EMAIL to complete the email verification process.

Forgot Your Password:

If you have forgotten your Cloud account password, press Forgot your password in the login page, enter your email address and press SEND EMAIL.



Cloud Control

To control the RV from cloud:

1. Launch the RVMaster App on your smart device.
2. Press Log in to BMPRO Cloud, or in General Settings, press Remote Connection.

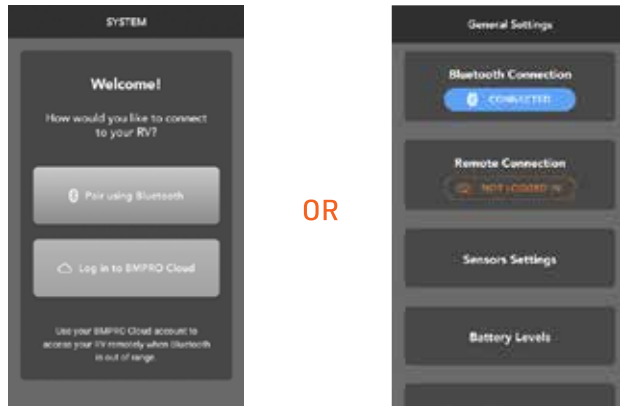

OR

3. Enter your email address and password.
4. Press Log in.

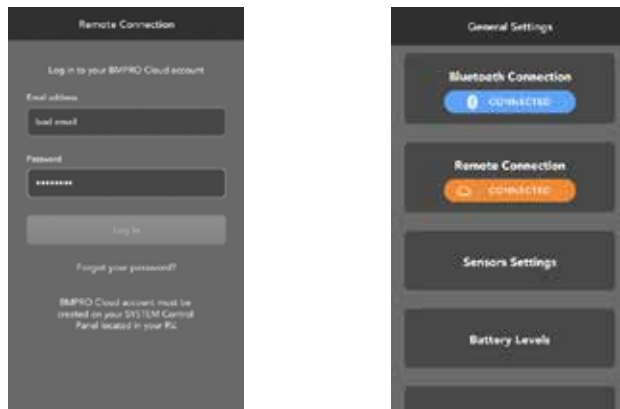

SUCCESS!

Use cloud control to remotely monitor and control features in your RV.

For your safety and for the prevention of unintentional damage, the leveling, motor controls and the water pump ON switch can not be controlled from the cloud.

Multiplex systems information courtesy of Firefly Integrations and BMPRO USA.

Remote Switch (Master Switch)

Your motorhome may have one or several wall-mounted remote switches installed, typically in the bath and bedroom or bunk areas. The RVMasterSwitch is an optional wall switch available in three types of configurations to suite your motorhome's configuration. The RVMasterSwitch communicates by Bluetooth to the RVMasterNode to provide convenient control of electrical features and accessories.

Any RVMasterSwitch installed in your motorhome will have been paired to the RVMasterNode at the factory and is ready to use immediately.

The RVMasterSwitch is powered by a standard, 3V Lithium Cell coin battery (CR2032). You can check if the battery needs replacing from the RVMaster App General Settings.

Open the BLE Wall Switches settings, then press any button on the switch whose battery you are checking. The RVMaster App will refresh with the switch battery status changes (installation of a new battery, for example).

To replace the battery:

1. Unclip the RVMasterSwitch button pad as shown in the illustration below.
2. Using a flathead screwdriver or similar tool, pry open the RVMasterSwitch button pad and remove the battery from the battery holder.
3. Insert the new battery in the battery holder with the positive side facing up.
4. Snap the switch pad closed.
5. Check the battery monitor to confirm the battery status.



Winegard 4G 2.0 Wi-Fi Extender

To set-up Winegard:

1. From the App home screen, press the Settings icon 
2. Select Winegard Settings

Logging into the Winegard Network

1. Press the search button to search for the available networks.
2. Select the desired network and enter the password or enter the network name and password. If your network is not seen, make sure the Winegard is turned on and scan again.
3. After the network name and password are entered correctly, press Join.



Internet Preferences:

You can select from the following options:

- 4G: Connect to a 4G network. SIM card required.
- WiFi: Connect to an external WiFi network.
- Internet Off: No Internet source selected.



Winegard Status

The current status of the Winegard is displayed on the Winegard tile in the General Settings area.

- **SETUP:** This is seen when no Winegard network has been connected previously. Press the tile to connect to a Winegard network.
- **UNAVAILABLE:** This means that the Winegard network is not available and may be seen during a transition from one mode to another. If Unavailable is displayed for a long time, check that the Winegard module is ON.
- **FETCHING INFO, CONFIGURING:** This may be seen during a transition from one mode to another, e.g. changing from WiFi to 4G.
- **4G:** This is seen when the Winegard is set to 4G. The status of the network is also displayed, e.g. Connected to 4G/LTE "NetworkName Data Plan."
- **WiFi:** This is seen when the Winegard is set to WiFi. The status of the network is also displayed, e.g. Connected to WiFi "NetworkName."
- **Internet OFF:** This is seen when the Winegard is set to WiFi. The status of the network is also displayed Internet is off.

WiFi Properties:

To log in to a WiFi network:

1. Press the Search button for a list of available networks and select your desired network.
2. If your network is not seen, make sure the Winegard is turned on and scan again. After the network name and password are entered correctly, press Join.

Save and/or forget WiFi Network:

After the WiFi credentials are entered, the WiFi network will be saved.

- Press Join to connect last saved network.
- Press X to delete the saved network.

This page is intentionally blank

Section 9: Electrical System

12 Volt Power System Introduction

⚠ WARNING

Whether a device or appliance operates on 120-volts AC or 12-volts DC, great care must be observed while using any electrical device and working with electrical wires and connections. Although all electrical circuits of your motorhome are protected by either fuses or circuit breakers, the electrical system has the potential of delivering dangerous electrical shock or the possibility of fatal electrocution. A qualified electrical technician should perform all maintenance and repairs to the wiring, devices, or components of the electrical system.

NOTICE

During very cold or very hot weather conditions, the image on touchscreen control panels (radio, multiplex, and other liquid crystal display (LCD) panels may appear unclear or react slowly. Once the interior temperature of the motorhome stabilizes, normal LCD panel display and operations will resume.

Your motorhome's electrical system is designed to provide safe, reliable energy to power the mobile features that enhance the RV'ing experience. The electrical system is a blend of two distinct electrical platforms, consisting of a 120-volt alternating current (VAC) system, and a 12-volt direct current (VDC) system. The 12-volt DC system is further segregated into the coach and the vehicle segments. Both the AC and DC power systems are required for your motorhome to function as intended.

Most of the electrical components of your motorhome are designed to operate on 12-volts DC. This includes lights, furnace and water heater control, water pump, powered ventilation fans, awnings, and some appliances. While other features, like the microwave oven, air-conditioner, TVs, and DVD players operate on 120-volts AC. Provided with your motorhome are power outlets for both 120-volts AC and 12-volts DC; so that you can conveniently power portable appliances you bring along while traveling.

NOTE: Due to model variations, options, and continuous production changes offered by TMC, wiring diagrams are not included in this manual. Any specific questions you may have regarding the electrical system of your motorhome should be directed to your Dealer or to TMC's Customer Care.

Power for the 12-volt DC electrical devices installed in your motorhome is supplied either by the on-board battery(ies) or by the converter when connected to shore power or when the generator is operating.

There are several devices of the electrical system that are designed to control 12-volt power to and from the motorhome's auxiliary (coach) and chassis batteries. Battery power management is important in order to:

- Turn the 12-volt electrical power ON and OFF
- Charge the auxiliary and chassis batteries
- Manage battery power output
- Monitor battery charge condition
- Control 12-volt devices

Following, is a brief description of the electrical devices used to control the 12-volt power system of your motorhome.

Master Battery Switch

⚠ CAUTION

Turning the Master Battery Switch OFF does not totally isolate the battery from the entire 12-volt electrical system. Some devices, such as the solar charge controller, are connected directly to the battery. Use caution when performing maintenance on the 12-volt system of your motorhome.

NOTICE

When traveling, the master battery switch must be turned ON to operate the dash radio and backup camera system (if equipped).

The Master Battery Switch is typically located just inside the motorhome's main entrance. It is used to connect power from the auxiliary battery(ies) to the motorhome's 12-volt DC fuse panel, hereby providing power to the motorhome's interior lighting, refrigerator, and other 12-volt DC devices.



Master battery switch

Using the master battery switch:

It is good practice to turn the master battery switch ON when first entering the motorhome and leave the switch ON whenever the motorhome is occupied, whether parked or traveling.

- This will energize the 12-volt electrical system, so that interior lights, appliance control circuits, and other 12-volt devices can be used.
- With a Re(Li)able Lithium Battery System installed, the master battery switch turns ON and OFF the system's inverter; making 120-volts AC sourced from the battery(ies) available.
- This provides charging voltage to the auxiliary battery(ies) via the vehicle's alternator (when traveling) or by the converter when connected to shore power or using the on-board generator (if equipped).
- This will provide power to the dash radio, which is powered by the auxiliary battery(ies). Therefore, keeping the master battery switch ON while the motorhome is in motion, allows the use of the dash radio and driving cameras, which in most installations, use the dash radio display for rear-view and side view camera monitoring.
- When leaving the motorhome unattended for a few hours or more and not connected to shore power, turn the master battery switch OFF to conserve battery power, unless there is a need to keep an appliance, like the refrigerator, operating.
- When connected to 120-volt shore power or the on-board generator is being used (if equipped), the 12-volt system is powered through the converter, therefore, the master battery switch is not controlling 12-volt system power. However, when connected to shore power or operating the on-board generator, charging voltage is provided to the auxiliary battery(ies) whenever the master battery switch is ON.

NOTES:

- *The Solar Charging System Controller is powered directly from the auxiliary battery(ies), therefore, it is ON regardless of the position of the Master Battery Switch.*
- *For TMC Class B Motorhomes equipped with a Re(Li)able Lithium Battery System, connecting to shore power will provide charging energy to the auxiliary battery(ies) via the Inverter/Charger, regardless of the position of the master battery switch. Turning the master battery switch ON and OFF controls the Inverter section only.*

Auxiliary Battery(ies) (Lead-Acid)

WARNING

- **Do not store items in the battery compartment or near the battery(ies) that might come in contact with the battery terminals. This could cause an electrical short circuit, drain the battery, cause a spark, or ignite combustible materials.**
- **Keep sparks, cigarettes, and flames away from the batteries as the hydrogen gas they create may ignite.**
- **Do not connect a booster battery or other power source that outputs more than 14.2 volts DC to the motorhome batteries.**
- **Use adequate ventilation when charging or using batteries in an enclosed space.**
- **Remove metal jewelry and always wear eye protection when working around batteries.**
- **Do not allow battery electrolyte (acid) to come in contact with skin, eyes, fabric or painted surfaces. Electrolyte is a sulfuric acid solution that could cause serious personal injury or property damage.**
- **If your hands, eyes, clothes, or the painted surface of your motorhome are exposed to electrolyte, flush the exposed area thoroughly with water.**
- **If electrolyte gets in your eyes, immediately flush them thoroughly with water and get prompt medical attention.**

Unless your motorhome is equipped with the optional Re(Li)able Lithium Battery Power System, your motorhome is supplied with lead-acid, deep-cycle type storage battery(ies), similar to the batteries found in recreational boats and golf carts. Deep cycle batteries are designed to be less susceptible to internal damage when operated in cycles of near depletion (discharge) and full recharge. Depending upon the features installed, the motorhome may be supplied with more than one auxiliary battery. Auxiliary batteries are typically located underneath the motorhome, secured and protected by brackets.

NOTES:

- *Use the multiplex display panel to check the condition of the auxiliary battery(ies). A fully charged lead-acid battery will read 12.7 volts DC. A lead-acid battery is considered discharged at 11.8 volts DC by electronic standards.*
- *When voltage drops below these levels, permanent damage may occur. Due to their large energy storage capacity and depending on the rate of depletion, it may take up to 24 hours for a lead-acid battery to fully recharge.*

Emergency (Auxiliary) Start Switch

NOTICE

Turn off all 12-volt DC devices before using the emergency start feature. This will help ensure that all available energy stored in the auxiliary battery(ies) can be used for vehicle starting.

Your motorhome may be equipped with an Emergency (auxiliary or AUX) start switch. Located in the vehicle's cockpit, near the drivers seating area, this switch connects the auxiliary battery(ies) to the vehicle's starting circuit to provide additional starting power.

This feature is used for situations when the chassis battery is too depleted to start the vehicle on its own. Connecting the auxiliary battery(ies) to the engine starting circuit may provide the needed energy to start the motorhome's engine. When the Emergency Start Switch is released, the auxiliary battery(ies) is disconnected from the engine starting circuit.

The Emergency Start Switch is available on ProMaster and Transit-based Class B motorhomes equipped with either standard AGM batteries or a Re(Li)able Lithium Battery power system and select Sprinter-based Class B motorhomes.

To operate:

1. Ensure the master battery switch is ON.
2. Depress and HOLD the 'EMER START' switch, located on the front driver's dash.
3. Use the ignition switch (key or start button) to start chassis engine.
4. Release the 'EMER START' switch after the engine has started.

NOTE: When using the Emergency Start feature, do not hold the ignition key in the start position for more than 30 seconds.

EMERGENCY STARTING TIP: If your vehicle battery is too depleted to start the engine, and the auxiliary battery(ies) is also too depleted, try operating the generator (if equipped) for a short period (with the master battery switch ON). This might provide enough charging energy to allow the vehicle to be started via the Emergency Start feature.

Chassis Alternator

Applies to Class B motorhomes equipped with a standard generator:

The 12-volts DC chassis alternator supplies power to the automotive systems as well as charging energy to the auxiliary batteries while the motorhome's engine is running.

When driving, if the alternator is not keeping pace with the draw on your motorhome's electrical system, it means it is working in a negative mode; more power is being used than the alternator is capable of supplying. If you draw too much power from your batteries, there may not be enough power left to start the motorhome or run the 12-volts DC appliances when you stop for a break or for the night.

The alternator will charge at a higher rate right after the motorhome has been started, replacing the power used to start the vehicle, but the charging should quickly drop back to 'normal' and hold its own even when you turn on lights or appliances.

If the alternator shows a discharge while the vehicle's engine is running, turn OFF appliances and lights to see if a charge comes on or if the alternator indicates 'neutral.' Then apply a load (turn ON a 12-volt DC appliance) on the system to see if a discharge returns. If a discharge persists, your alternator may not be working correctly; contact your dealer.

NOTE: If your motorhome is equipped with the optional Re(Li)able Battery Power System, there is an additional alternator installed on your vehicle that is specifically designed to charge the lithium-ion battery system.

Battery Access

⚠ CAUTION

Due to the mounting position of the auxiliary batteries, they may be subject to damage due to road hazards or other travel-related issues.

Regularly inspect the batteries for damage. Be extremely cautious of leaking batteries and loose or damaged electrical connections.

Do not use the 12-volt battery system if any battery damage is detected and until proper repairs are performed.

The auxiliary batteries are located underneath the vehicle, secured by mounting brackets. The vehicle must be raised to access the batteries. Always secure a raised vehicle with jack stands or other devices. Refer to the vehicle manufacturer's owner's manual for proper jacking procedures.

For long battery life, it is important to keep your motorhome batteries fully charged as much as possible. Turn OFF lights and other 12-volts DC components when they are not being used. Connect the motorhome to a 120/220 volts AC power source (shore power) whenever possible.

Battery Charging

WARNING

NEVER SIMULTANEOUSLY CHARGE A BATTERY FROM SHORE POWER AND THE ENGINE ALTERNATOR:

Excessive charging energy will result in battery damage.

It is important to keep the auxiliary battery(ies) in a condition of full or near-full charge. Doing so will ensure you will have enough stored 12-volt DC energy when needed. Battery charging is accomplished by:

- Automatic charging through the converter (shore power or generator);
- With the vehicle engine running, auxiliary battery(ies) are charged via the chassis alternator (when master battery switch is ON);
- Auxiliary battery charging via solar charging system (equipped as standard, optional, or customer installed).

Take time to turn off all lights or other 12-volt accessories when not in use. Connect the motorhome to a 120-volt AC external source or run the generator whenever possible. Doing so will keep the auxiliary batteries charged.

The auxiliary batteries are a deep-cycle type and are capable of being deeply discharged and rebound to full capacity when recharged. Due to their large energy storage capacity, the auxiliary battery(ies) may take up to 24 hours to completely recharge.

If for any reason, you recharge a auxiliary battery with a charger or power source other than what was supplied as part of the motorhome's original electrical system, make sure to follow all battery maintenance and safety instructions from the battery and battery charger manufacturers.

Charging by the Vehicle's Alternator

Applies to Class B motorhomes equipped with a standard generator:

The motorhome's electrical system is wired so that when the vehicle's engine is running, and the chassis alternator is properly operating, charging voltage is supplied to both the

chassis and auxiliary battery(ies). The master battery switch must be ON in order for the auxiliary battery to be charged by the chassis alternator (see Chassis Alternator and Battery Isolation Relay Sections).

Charging by the Converter

Applies to Class B motorhomes equipped with a standard generator:

The Converter is a 12-volt power supply, which operates on 120-volts AC (see Converter section) and is designed to power the 12-volt system when the motorhome is connected to shore power or when the generator is running. The Converter also provides charging energy for the auxiliary (coach) battery(ies).

If the battery condition is below its full charge, the charger will begin recharging the auxiliary battery at a rate that reflects the level of discharge. When the battery is fully charged, the charger drops its charging level back to a maintenance or trickle level to keep the battery fully charged.

Charging by Solar Energy

Applies to all Class B motorhomes:

CAUTION

Battery type selection on the controller determines charging parameters that best suit the battery type. Incorrect battery type selection settings may damage the battery.

NOTICE

TMC-installed solar controllers are always wired on the "hot" side of the master battery switch, meaning solar charging is active with or without the battery switch being turned ON.

Your Thor Motor Coach motorhome may be factory equipped with a solar battery charging system. Consisting of a solar charge controller, along with a roof-mounted solar panel(s). This system is designed to provide a readily available battery charging method for the auxiliary (house) battery(ies).

The solar charging system seamlessly integrates with your motorhomes 12-volt DC power system. The auxiliary batteries are automatically charged when the solar charge controller is ON. The solar charge controller provides monitoring of battery condition, monitoring of the charge energy being supplied by the solar panel(s), and regulation of the charging energy.

TMC installs two basic types of solar charge controllers:

- Stand-alone, PWM (pulse width modulated) with a 10 amp input rating. Installed in motorhomes without a multiplex wiring system.
- RV-C compatible MPPT (Maximum Power Point Tracking), with either a 10 amp or 30 amp input rating. Installed in motorhomes with a multiplex wiring system.

Where the stand-alone controller uses a built-in LCD display and front-panel switches to monitor and make system selections, the RV-C compatible controller interfaces directly with the motorhome's multiplex system, allowing monitoring and settings functions through the multiplex system's touchscreen display.

Both controller types feature charging parameters that can be selected for flooded, GEL, AGM, and lithium-ion batteries that contain an internal battery management system.

Basic Solar Charging System Description:

Solar controllers offer automatic, multi-stage charging parameters.

1. **Bulk Stage:** This algorithm uses 100 percent of available solar power to recharge the battery and provides the maximum current available based on maximum input current settings. In this stage, the battery has not yet reached its maximum (constant) voltage rating (typically 12 volts).
2. **Absorption Stage:** When the battery reaches its constant voltage (typically 12 volts), the controller will start to reduce input current, while maintaining the battery at its constant voltage level.
3. **Float Stage:** After the Absorption Stage, the controller reduces the current even further so that the battery voltage can reach and be maintained at a minimum charging energy level. Some battery chargers refer this stage as a 'Trickle Charge,' where the controller is allowing just enough current to maintain the battery's charge.
4. **Equalization Stage:** This stage is carried out on a typical 30-day cycle (by default). When enabled, Equalization intentionally overcharges the battery for a controlled time-period. Certain types of batteries benefit from a periodic equalization charge, which can 'stir' the electrolyte, thus creating a more uniform chemical reaction within the cells of the battery.

The maximum input current rating of the solar controller is 10 amps (energy supplied by the solar panel(s)). The typical factory-installed solar panel is rated for 100 watts (peak), with some solar panels having a rating of 200 watts (peak power). The output charge voltage is up to 14.4 volts DC.

Solar panel(s) installed on your motorhome may vary from these specifications; refer to your Owner's Packet for details.

Maintenance and operational instructions from the solar controller and solar panel manufacturer are included with your owner's packet and also available on-line through the TMC Owners Resource Information Service.

NOTES:

- *The factory-installed solar charging system is designed and programmed to work with the factory-installed battery system, whether the batteries are lead-acid, AGM or lithium. If you replace factory-installed batteries with another type, be sure to reprogram the controller so that the charging operation is compatible with the batteries.*
- *The solar charge controller and its solar panels are not designed to supply power directly to your electrical appliances and/or components installed on your motorhome. Its output is connected directly to the auxiliary battery (using an appropriately sized fuse), not to the 12-volt fuse panel.*
- *The peak power of solar panels comes from direct exposure to solar radiation. The useful power of solar panels depends on atmospheric conditions.*
- *The solar charger is powered directly from the auxiliary battery:*
 - › *Deactivating the main battery switch does not deactivate the solar charge controller.*
 - › *However, the main battery switch must be ON to monitor the RV-C solar controller (by activating the multiplex system touchscreen display).*

Solar Charging, 10 amp Controller

When installed, a 10 amp solar charging system includes 1 - 10 amp solar controller and 1 - 200 watt solar panel (190 watt with optional SkyBunk). This factory-installation is wired with 10 gauge wire from the solar panel to the solar controller and to the auxiliary battery. Due to controller capacity, DO NOT add additional solar panels to this system.

NOTE: For operating and other important details regarding your solar panel and solar charge controller installed in your motorhome, refer to the manufacturer's owner's manuals included with TMC Owner's Packet.



Go Power PWM 10 Amp Solar Charge Controller

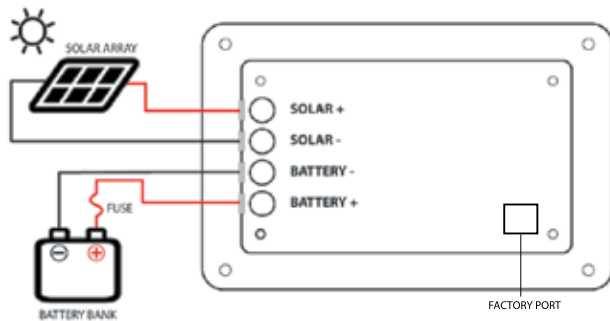

Typical solar charge controller wiring diagram.

Integrated Solar Charging Systems

Applies to Solar Charging Systems with Multiplex Integration

Your TMC motorhome may be factory-equipped with a solar charging system that is remotely controlled and monitored by the multiplex touchscreen panel. The solar charging system seamlessly integrates with your motorhome's multiplex control system, automatically providing an additional charging method for the motorhome's on-board house (auxiliary) battery(ies).

The auxiliary batteries continuously receive charging energy from the solar panel(s), regardless of whether the master battery switch is ON or OFF, unless the battery(ies) are disconnected at the terminals. Charging and battery condition is monitored on the multiplex touchscreen's solar menu. The remote solar charge controller senses the charging needs of the battery(ies), regulates the energy from the roof-mounted solar panel(s) to the battery(ies) (determined by type and charging profile of the auxiliary batteries installed), and sends system monitoring information to the multiplex touchscreen.

Additionally, and via the multiplex touchscreen, users can select pre-set and custom operating parameters for the solar charging system.

When the controller senses that the auxiliary battery(ies) require charging, the controller cycles through multiple stages of internally programmed charging parameters. This multi-stage process is designed to rapidly re-charge the batteries, while protecting the batteries from damage due to over-charging and over-heating.

Depending on the model, the maximum input current rating of the remote solar controller is 10 or 30-amps, which, for safety reasons, is designed to be a bit higher than the maximum (peak) amperage that the installed solar panel(s) can provide. The typical factory-installed solar panel is rated for 100 watts (peak), with some solar panels having a rating of 190 and 200 watts (peak power). Solar panel(s) installed on your motorhome may vary from these specifications; refer to your Owner's Packet for details.

The solar charge controller and associated solar panels are not designed to directly power the appliances and/or electric components installed in your motorhome. All 12-volt systems and components are either powered directly from the auxiliary batteries or by the converter, which receives input power from either the on-board generator or an external shore power source.

Operational and maintenance instructions from the manufacturer of both the solar controller and the solar panels are available on-line, through the TMC Owners Resource document service.



Integrated Solar Control. Illustration of Firefly touchscreen panel. The solar charging screen on your multiplex system may vary from this illustration. With the Firefly system, solar control set-up is accessed either by a menu tab (configuration) or a set-up button.

Solar Panels

⚠ CAUTION

Due to the solar panel mounting position, which is usually between the roof-rack rails, be extremely cautious when carrying cargo on the roof rack. Never place items directly on top of the solar panel. Any amount of cargo weight that is in direct contact with the solar panel could easily and permanently damage the solar panel.

NOTICE

When installing a roof-mounted solar panel(s), ensure they are securely attached to mounting brackets and to structural components of the motorhome's roof. All mounting points and wiring ports **MUST** be well sealed from moisture intrusion.

Your motorhome may be equipped with a 100 watt-to-200 watt solar panel as a standard factory-installed feature. When installed, a solar panel and associated power controller becomes part of the auxiliary (coach) battery charging system.

The wattage rating of your solar panel was derived by a standard test method that all solar panel manufacturers use. This rating represents the solar panel's peak output under ideal conditions of sunlight intensity, direction, cleanliness of the surface and temperature of the panel. There are many atmospheric factors and physical conditions that will affect the output of your solar panel. On average, however, you should expect the output of your solar panel to be approximately 75-80 percent of its peak rating.



Typical solar panel installation

Auxiliary Solar Panel Port

⚠ CAUTION

If additional solar panels are desired, always consider the input amperage limit of the solar controller. To prevent possible controller or charging system damage, **DO NOT** exceed the maximum limit of 200 watts of total solar panel energy with any single or multiple solar panel array.

When connecting an auxiliary solar panel to the auxiliary solar panel port, always observe the polarity of an auxiliary solar panel and be sure the panel connector matches the polarity of the solar panel port.

As a convenient means of increasing solar charging capacity, an auxiliary solar panel port is provided. Typically located along the left side of the motorhome, a user-supplied portable solar panel can be plugged into the auxiliary solar panel port to augment the roof-mounted solar panel's energy output. However, the solar controller is limited to 10 amps maximum charging current output.

ALWAYS OBSERVE THE POLARITY OF AN AUXILIARY SOLAR PANEL WHEN PLUGGING INTO THE AUXILIARY SOLAR PANEL PORT.

Auxiliary solar panel port.
Typically located on the driver's side of the motorhome. NOTE polarity of the jack:

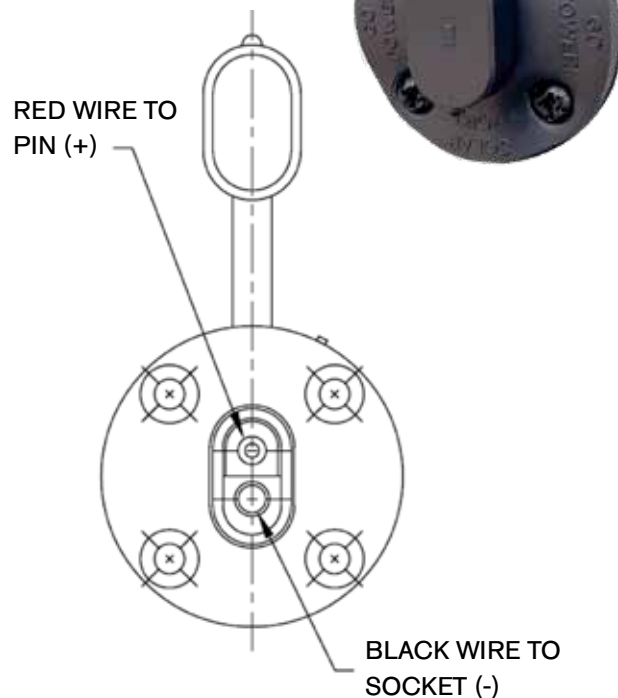

Battery Maintenance: Lead Acid Type

WARNING

- **Do not allow battery electrolyte (acid) to come into contact with skin, eyes, fabric or painted surfaces. Electrolyte is a sulfuric acid solution that could cause serious personal injury or property damage.**
- **If your hands, eyes, clothes, or the painted surface of your motorhome are exposed to electrolyte, flush the exposed area thoroughly with water.**
- **If electrolyte gets in your eyes, immediately flush them thoroughly with water and get prompt medical attention.**
- **Keep sparks, cigarettes, and flames away from the batteries as the hydrogen gas they create may explode.**
- **Do not connect a booster battery or other power source that outputs more than 14.2-volts DC to the motorhome batteries.**
- **Use adequate ventilation when charging or using batteries in an enclosed space.**
- **Remove metal jewelry and always wear eye protection when working around batteries.**
- **DO NOT SHORT ACROSS THE BATTERY TERMINALS. The spark could ignite the gases. Do not wear metal jewelry, such as rings, watches, or metal wrist bands when working on a battery.**
- **Before doing ANY work on electrical system, disconnect battery cable and the 120-volt power cord. Do not reconnect the cables until all work has been completed. This will avoid the possibility of shorting or causing damage to electrical components or shock to the servicing person.**
- **Battery electrolyte is a corrosive, poisonous, sulfuric acid. Avoid contact with skin, eyes, clothing, or any painted surface.**

WARNING

ALWAYS WEAR SPLASH PROOF SAFETY GLASSES OR FACE SHIELD AND USE ACID-PROOF RUBBER GLOVES WHEN HANDLING AND WORKING WITH LEAD-ACID BATTERIES.

Proper battery maintenance is important in order to ensure the battery retains its power delivery capacity while prolonging its useful life. Listed here are a few instructions for maintaining and servicing batteries. These instructions apply only to batteries which are NOT maintenance-free, or sealed batteries. The auxiliary batteries supplied with your motorhome may not be the sealed type, however, the chassis battery may be a maintenance-free, sealed type battery. Do not open or break seals on maintenance-free batteries.

1. Keep the battery mounted securely. Routinely check the battery terminals for loose battery clamps. Tighten when necessary.
2. Keep battery hold downs and trays clean and free of debris and corrosion.
3. Check the electrolyte level of the auxiliary batteries at regular intervals. Keep each cell filled to just above the plates with DISTILLED water only. Once the plates have dried out, they cannot be reactivated, and the capacity of the battery is reduced in direct proportion to the area of plate surface that has become dry. This kind of damage can occur quickly. If the fluid level is low, simply add distilled water.
4. Be cautious when removing battery fill caps. Pry off caps carefully. Forcing caps off can cause the electrolyte solution to splash. Electrolyte solution can burn, and even small amounts can damage eyes and skin. Always use proper personal protective equipment when working with batteries.
5. Keep the battery terminals clean. Corroded terminals make poor electrical contact and will prevent normal operation of the 12-volt system. Battery terminal corrosion occurs when the battery has been standing in a discharged condition over a long period of time, or when the battery has been operated continually in a state of partial discharge. Use a baking soda solution to neutralize the corrosion on the battery terminals and cable clamps. Do not allow the soda solution to enter the battery. Make sure the vent caps are secure. Flush with water. Thoroughly dry all cables clamps and terminals, reinstall, and use a battery terminal protecting spray or compound, available at automotive parts or auto service centers.
6. Check the outside condition of the battery. Look for cracks in the case or vent plugs. If the case is cracked, the battery must be replaced. If the vent plugs are cracked, they must be replaced.
7. Keep the battery in a full-charged condition. This will help prolong its useful life and help maintain its charge-holding capacity.
8. Watch for overcharging. Three indications of overcharging are:
 - a. Active material on the vent cap (heavy deposit of black lead-like material on the underside of the vent cap);
 - b. Excessive use of water or water escaping at vent caps;
 - c. Abnormal voltage regulator output.
9. When removing a battery, disconnect the ground battery clamp first. When installing a battery, always connect the grounded battery clamp last.

10. When replacing batteries, make sure the new battery is the same type and rating of the battery that was originally equipped with your motorhome. If in doubt, consult your RV dealer for advice on battery replacement.

NOTES:

- Only use distilled water when filling battery cavities. Be careful not to overfill battery cavities and never move or travel with a battery that is uncapped.
- Use a battery terminal conditioning spray (available at auto parts stores) to prevent battery terminal corrosion.

Battery Storage (Lead Acid or AGM)

To prevent auxiliary battery discharge when the motorhome is placed in long-term storage and NOT connected to trickle-charging through the shoreline power cord, turn OFF the main battery switch and disconnect the negative battery cable at the battery terminal.

However, while in storage, it is recommended to trickle-charge the battery(ies) through the shore power cord. The main battery switch needs to be ON and do not disconnect the battery terminals. This will allow the converter, or inverter (if so equipped), or solar charging system (if so equipped) to trickle charge the auxiliary battery(ies).

Battery Replacement

WARNING

TO PREVENT HAZARDS FROM DANGEROUS BATTERY GASES:

If replacing or adding additional batteries to the 12-volt electrical system, ensure batteries are always located in a well-ventilated area and separated from the living space of the motorhome.

Always add or replace batteries with the same type that was originally equipped with your motorhome. Never mix AGM/AGS batteries with Lithium-Ion batteries.

When replacing batteries, make sure the new battery is the same type and rating of the battery that was originally equipped with your motorhome. If in doubt, consult your selling dealer or a qualified RV technician for assistance. Always re-connect the battery cables in the original factory-installed positions.

- Do not replace a deep cycle battery with a starting battery. Only use deep cycle batteries for your motorhome's auxiliary application.

- Do not replace your chassis or starting battery with a deep cycle battery. A starting battery is designed to deliver higher instant amperage, needed to start the vehicle's engine.
- Check to be sure the replacement battery will fit the battery tray of your motorhome. Group 24 batteries are physically smaller than Group 27 batteries.

Inverter (Non-Lithium Battery Systems)

CAUTION

The standard inverter installed in your motorhome is not rated to supply the electrical energy for the roof air-conditioner. Use shore power or generated power (from the generator) to power the roof air-conditioner.

CAUTION

Inverters are rated in wattage, which is the maximum electrical energy they can deliver. Do not attempt to operate higher electrical loads than the inverter is designed to supply.

The factory installed inverter is a device that converts 12-volts DC, supplied by the auxiliary battery(ies), to usable 120-volts AC. It provides continuous AC power to appliances, entertainment devices, and select circuits. Use the inverter to power small 120-volt AC appliances when shore power is not available and when operating the generator is not permitted or feasible.

A remote panel may be installed that duplicates the ON/OFF power switch and other functions located on the front panel of the main unit. In addition to the power switch, the remote panel features a green power status LED. The inverter should be turned OFF when the motorhome is in storage.

Although wiring varies from model to model, in general terms, the inverted-powered outlets are those that feed power to the TV and a few essential AC power outlets.

All inverters have a wattage rating that will indicate the maximum load (or electrical power) the inverter can supply. For example, an 1,000 watt inverter will be able to provide approximately 8.5 amps of current (amperage). Sometimes, the wattage capacity is stated in kilowatts (kW). For example, 1,000 watts becomes 1.0 kW. Depending on the model and floor plan, TMC typically installs inverters with power ratings of 1,000 watts in Class B motorhomes.

Since the inverter is drawing power from the auxiliary battery(ies), the condition and storage capacity of the batteries determines how long the inverter can supply power to your 120-volt AC devices. Keep in mind that while traveling, a charging voltage to the batteries from the vehicle's alternator is available, as long as the master battery switch is ON. Maintaining a charging voltage to the auxiliary battery(ies) will prolong the energy available from the battery(ies) to the inverter.

Battery voltage is also important for proper inverter operation. Most inverters have an automatic shut-off feature that turns the inverter off in the event that the incoming voltage of the supply battery(ies) drops out of range; usually below 10 volts DC or above 16 volts DC.

For details regarding the inverter supplied to your motorhome, its features and functions, please refer to the manufacturer's operational guide included with your Thor Motor Coach Owner's Packet, available through the TMC Owners Resource service, or directly from the inverter manufacturer's website.

Inspection and Maintenance

Most inverter installations include a separate circuit breaker installed near the auxiliary battery(ies). This circuit breaker protects the inverter from overloads (attempting to draw more power from the inverter than it is designed to supply). If the inverter is not working, check to determine if this circuit breaker is 'tripped' (device with a blue reset button). If so, re-set it and reduce power consumption through the inverter.

Also check the fuse located on the inverter. Inverters are typically installed behind a panel or bed pedestal near the Power Load Center (fuse and circuit breaker panel). There are no consumer serviceable parts inside the inverter case and the manufacturer's warranty will be void if the case has been opened. The inverter's cooling fins and the cooling fan must be kept clear of any obstructions. If you have further concerns, contact your dealer.

NOTES:

- *The condition of the auxiliary battery should be monitored when using the inverter. During some load conditions, it is possible to completely deplete the stored energy of the battery(ies).*
- *Calculating the total power consumption (in watts) is very important for proper inverter use. DO NOT exceed the power output rating of your inverter.*
- *Inverters will safely operate most AC loads within their power rating. However, some appliances and equipment may not operate correctly with the mod-*

ified sine wave of inverted power and actually be damaged if operated by an inverter. It is especially important to check all medical devices to determine if they can operate safely with inverted power.

- *Inverters that are factory supplied with the optional Re(Li)able Battery Power System have a higher output wattage rating as compared to the standard inverter. This higher wattage unit is capable of supplying enough energy to operate the coach air-conditioner and other 120-volt AC appliances.*
- *Electrical diagrams for your motorhome will indicate inverted circuits and are available through the on-line Owners Resource service.*



Typical 100 Amp Inverter Circuit Breaker located on a frame member underneath the vehicle, near the battery trays.



NOTE: An extended yellow lever indicates a tripped circuit breaker. Locate and correct the overload, then move the lever back into the housing. The blue button is a circuit breaker test device. Pressing the blue button will disconnect the inverter from the battery(ies).

Re(Li)able® Battery Power Systems

DANGER

WHEN REPLACING AND TRANSPORTING BATTERIES, MAKE SURE THAT:

- The battery remains in its original housing or container.
- The battery remains in an upright position.
- Soft straps are used to avoid damage.
- Avoid being underneath the battery during removal and replacement.
- Only lift the battery by its handles.
- Always handle the battery with care.

WARNING

Read and follow all manufacturer's safety precautions and operational instructions for the Li-ion battery power system; including the battery pack, system control panel, inverter/charger, and auto-start module.

Ensure all users are fully familiar with the battery power system's operation and safety instructions.

Severe injury, fire, or system damage could occur.

WARNING

The battery(ies) contains hazardous materials that are contained safely during normal use. Do not crush, open, or drop the battery. Do not touch or ingest any of the released material or inhale released gases when accidental leakage of the battery occurs.

Should skin contact, eye contact, or inhalation occur, perform the necessary first aid measures immediately. Refer to the Material Safety Data Sheet for Mastervolt Lithium-ion batteries, which is available on the web: www.Mastervolt.com.

WARNING

Simultaneous contact of the positive terminal and negative terminal with a metal object will cause a short-circuit of the battery. Short-circuit may result in fire, explosion, electric shock, or release of toxic gas.

Use insulated tools only and keep metal objects away from the battery. Do not wear watches, bracelets, necklaces, or other metal objects when working on the battery. In case of fire, take necessary firefighting measures immediately. Refer to the Material Safety Data Sheet for Mastervolt Lithium-ion batteries, which is available on the website: www.Mastervolt.com.

WARNING

The battery area/compartments for the system's Li-ion battery(ies) is designed for the use of non-vented batteries only.

Do not place a battery that requires venting into this area/compartments. Vented batteries can release poisonous and flammable gases.

Can lead to a fire or explosion and result in death or severe injury.

WARNING

Short circuits, too deep discharges, and too high charge currents will damage the battery and may result in fire, explosion, electric shock, or release of toxic gas. Always install an external safety relay!

NEVER CHARGE A BATTERY:

- When the safety relay(s) have tripped.
- After it was discharged below the Discharge Cut-off Voltage.
- When the battery is damaged.
- When the battery was overcharged.
- If in doubt, contact the manufacturer, Mastervolt: www.Mastervolt.com.

WARNING

NEVER SIMULTANEOUSLY CHARGE A BATTERY FROM SHORE POWER AND THE ENGINE ALTERNATOR:

EXCESSIVE CHARGING ENERGY WILL RESULT IN BATTERY DAMAGE.

WARNING

Never open the connector lid on top of the battery. Doing so may cause damage to the printed circuit board.

CAUTION

Due to the mounting position of the auxiliary batteries, they may be subject to damage due to road hazards or other travel-related issues.

Regularly inspect the batteries for damage. Be extremely cautious of leaking batteries and loose or damaged electrical connections.

Do not use the 12-volt battery system if any battery damage is detected and until proper repairs are performed.

NOTICE

- **The voltage range (12.0-14.6V or 24.0-29.2V is larger than you may expect from other battery types, such as lead-acid batteries. Be aware that these voltages could exceed the permitted voltages of the connected electrical devices (load(s)).**
- **The components of the Re(Li)able Battery Power System are designed and manufactured with high quality materials and components, which can be recycled and reused. Follow local safe disposal practices—never dispose battery system components with normal household waste. Always dispose components through an authorized waste management facility.**
- **Power for the inverter/charger is remotely switched through the rotary master battery switch. Turn ON the master battery switch to operate the Li-ion battery system.**
- **If the inverter does not provide AC power with the master battery switch ON, check the power switch on the bottom of the inverter/charger; it should be kept in the OFF (0) position.**

Introduction

Lithium-ion battery power systems are available as either standard or optional equipment on select TMC Class B motorhomes. When installed, this power system replaces the traditional on-board generator, converter, and AGM batteries; providing a clean and reliable off-the-grid energy source for all 12-volt DC and 120-volt AC electrical devices of the motorhome.

The lithium-ion battery pack delivers twice the power at 1/3rd the volume and 1/6th the weight as compared to standard lead acid batteries. The battery packs are designed for long life, outlasting traditional batteries by up to 5 times.

The Battery Power System Components:

- **Lithium Iron Phosphate (LiFePO₄) battery pack(s)**
Depending on the installed system, individual lithium-ion battery pack ratings are 12-volt, 100 Amp hour (Ah); or 12-volt, 460 Ah capacities. TMC's Re(Li)able Battery Power Systems can consist of single or multiple battery packs.
- **High-capacity Inverter/Charger**
All TMC Re(Li)able Battery Power Systems use Mastervolt's CombiMaster high-capacity inverter/charger, rated at 3,000 watts output, and delivering a true sine-wave, 120-volts AC. When plugged into a 30-amp shore power source, automatic battery charging is provided through this inverter/charger.
- **System Control Panel and Monitoring**
Depending on the installed battery system, battery power monitoring and control for battery charging and inverter output is provided by an easy-to-use battery monitor and smart-controller.
- **High-output Alternator**
While operating the vehicle, battery system charging is provided by a second, high-output alternator. The installed alternator's output is rated for 170 Amps.
- **Auto-start Charging Module (optional with select systems only)**
Select systems include a programmable auto-start feature, which when activated and low system voltage is detected, will automatically start the vehicle's engine when parked, thus providing off-grid charging energy to the system batteries via the secondary alternator.
- **Solar Charging System**
All Class B Re(Li)able Battery Power Systems include a solar charging system, consisting of a 200 watt solar

Re(Li)able Lithium Battery Power Systems								
System Designation	System Energy (Watt-hr)	System Capacity (Amp-hr)	Battery Brand	Battery Quantity	Inverter Capacity (Watts)	Autostart	Available on TMC Brand	Standard/Option
Re(Li)able V1 Energy	6,000	460	Mastervolt	1	3,000	N/A	Sanctuary/Tranquility	S
							Eddie Bauer	S
Re(Li)able V2 Energy	5,120	400	ReLion	4	3,000	Yes	Palladium/Talavera	S
							Sequence/Tellaro	O

TMC reserves the right to make changes to standard and optional features and specifications, battery suppliers, battery type, battery power system ratings, or any battery system specifications, or battery system component or components without prior notification or obligations to provide similar features, systems, or components to previously built or sold vehicles or future vehicles built and sold by TMC.

panel and integrated system controller that monitors system voltage and provides optimum battery charging depending on weather conditions. Also included is an electrical port to connect an additional portable solar array (user provided).

A Lithium Battery Power System Matched to Your Power Needs

TMC offers Re(Li)able Battery Power Systems in two amp-hour-rated sizes. Available systems are dependent upon standard and options for the TMC Class B brand and floor plan.

- **Re(Li)able V1 Energy: 460 Amp Hour System**
Standard on select models: A 6,000 Watt-hour (Wh), 460 Amp-hour (Ah), single lithium battery pack (LiFePO₄), including a 3,000 Watt inverter/charger, and 170 Amp charging alternator.
- **Re(Li)able V2 Energy: 400 Amp Hour System**
Standard and optional on select models: A 5,120 Watt-hour (Wh), 400 Amp-hour (Ah) lithium battery system, consisting of 4-100 Ah LiFePO₄ batteries with a 3,000 Watt inverter/charger and 170 Amp charging alternator.

Safety Guidelines

- Read the manufacturer's manuals before using the battery power system and keep the manuals for future reference.
- Do not use the battery or battery system for purposes other than the intention for which it is installed.
- Maintenance or work on any part of the battery system should only be carried out by a qualified technician.
- Non-compliance with operating instructions, non-qualified repairs, or repairs made with other than original parts, or repairs made without authorization may void manufacturer's warranty.
- Higher-powered Re(Li)able battery systems use safety relays to give the battery system an extra layer of operational safety. Never bypass or in other ways disable the battery power system's safety relays or other safety-related components.
- Installation using Mastervolt battery pack(s) requires programming of events in a MasterBus network. The installer must be familiar with the programming of such events.
- System installations, connections, and safety features must be performed according to the locally applicable regulations and industry standards.

- Use electrical cables and connection devices that are appropriately sized and rated for the intended power requirements.
- Never use the battery in situations where there is danger of fire or explosions due to the presence of flammable gas, liquids, or potentially flammable materials.
- Only use batteries in a well-ventilated area and protect the connector hatch from moisture and dust. Do not obstruct the ventilation openings on any system device, including battery(ies), inverters, chargers, switches, and control devices.
- Never short the battery terminals! Excessive heat, fire, and risk of explosion exists.
- Switch off all charging systems and disconnect the batteries from the electrical installation during maintenance and/or repair activities.
- Never charge an extremely cold lithium-ion battery; the battery can be severely damaged by high charging current when its internal temperature is below the manufacturer's recommended low temperature operating limit. See manufacturer's recommendations for cold temperature operation.

ALWAYS FOLLOW THE MANUFACTURER'S INSTRUCTIONS FOR BATTERY INSTALLATION, PREPARATION, OPERATION, AND DISPOSAL.

Basic System Operation

TMC Re(Li)able battery power systems are designed to be easy to use and as trouble-free. However, for optimal performance, it does require users to have a good understanding of system capabilities, safe usage, maintenance, and proper storage.

Below are basic instructions on how to operate the system. More advanced instructions are contained in following sections of this manual.

- When entering the motorhome, turn ON the rotary master battery switch. Doing so powers the 12-volt system, along with the inverter/charger (allowing use of 120-volt AC devices). The master battery switch must also be ON in order to power the dash radio and back-up monitor and power the combination LP/CO detector.
- When parked and connected to shore power, the master battery switch also must be ON in order to allow full operation of all electrical functions of the motorhome. However, the charger section of the inverter/charger is always active when connected to shore power, regardless of the state (ON/OFF) of the master battery switch. See "The Master Battery Switch" on page 89.

- When not connected to shore power, the lithium battery power system provides power for all electrical devices, both 12-volt DC and 120-volt AC.
- Use the multiplex control panel to monitor and control the electrical systems of the motorhome.
- Turn OFF the master battery power switch whenever leaving the motorhome for an extended time-period. Doing so will prevent unnecessary battery drain. However, your motorhome may be equipped with an electric-only refrigerator (12-volt DC, compressor-type). If you need to keep the refrigerator running while parked and NOT connected to shore power, keep the master battery switch ON, while ensuring other 12-volt DC and 120-volt AC devices remain OFF.
- **CAUTION:** Never sleep in the motorhome with the master battery switch OFF, for this would make the LP/CO detector non-operational. However, the smoke detector is powered by its own internal battery.
- Use the battery monitor to monitor the charge condition of the auxiliary battery(ies).
- Use the battery system controllers (SmartRemote or EasyView 5) to manage the Mastervolt inverter/charger and system battery(ies).
- It is good practice to keep the solar charge controller ON, providing solar charging to the auxiliary battery(ies).
- When the battery(ies) become low (less than 20% remaining charge), re-charge them by using either method available:
 - › Shore power via the inverter/charger (the most preferred method). Charging is automatic with this method.
 - › Start the vehicle's engine and use the auxiliary charging alternator (a good method, but depending on the total battery capacity of the system (amp-hours), this could take several hours to charge the batteries).
 - › Use the solar charging system; an environmentally friendly method, but a long charging process due to the limitations of the solar charge controller and solar panel electrical generating capacity. W

NOTES: RV roof air-conditioners typically draw 1,200-1,500 watts. The Re(Li)able battery power system is designed to operate the roof air-conditioner via the inverter/charger. However, operational times will vary due to the capacity of the battery system installed and other environmental factors.

For complete information regarding the operational and maintenance procedures of the Re(Li)able Lithium Battery System and its components, please read information available from the component manufacturers websites and on-line through your TMC Owners Resource account:

Re(Li)able® V2, 400 Amp-Hour System

NOTE: The master battery switch must be ON to operate the electrical devices of your motorhome. This includes whether electrical power is being supplied by the lithium-ion battery system or by a shore power source.

Power Sources

Shore Power

When shore power is available, 120-volt AC electrical devices are powered by the external AC source. Incoming AC is passed through the system's inverter/charger, via an internal transfer switch; then out to an on-board fuse/breaker panel, in which the electrical devices of the motorhome are connected. 12-volt DC powered devices, such as internal lights, awnings, and electronic device charging stations are powered by the system's 12-volt batteries. At the same time 12-volt electrical power is being discharged from the battery(ies), the battery(ies) are receiving recharging energy from the

charger section of the inverter/charger. The on-board solar charging system will also supply restorative energy to the batteries whenever the solar controller is ON and weather conditions permit the solar panels to generate electricity.

If the AC load demand is high, the circuits in the inverter/charger automatically reduce the power going to charge the batteries, therefore making more energy available for the motorhome's AC powered devices (up to the full amperage of the incoming source).

If the AC load is still above the potential of the incoming AC source, the inverter/charger will automatically augment the AC supply by providing additional AC power from the system's batteries via the inverter.

NOTE: The 120-volt AC load of the motorhome's electrical devices should never exceed 40 amps. Exceeding 40 amps could damage the inverter/charger.

Off-the-grid Power

When shore power is not available, power for both the AC and DC electrical devices of the motorhome is supplied by the on-board lithium batteries. 12-volt DC power is supplied directly by the auxiliary batteries and 120-volt AC power is supplied by the inverter, which draws its power from the 12-volt system batteries.

While operating the electrical devices of the motorhome strictly by the battery power system, being mindful of electrical loads and power demands is very important. Load shedding, as described in the next section, is employed when high-energy demand appliances are used. However, due to the limited availability of power from the on-board batteries (400 Ah maximum from fully-charged batteries), one should always be conservative with power use whenever shore power is not available.

NOTE: When operating off-the-grid, always take advantage of the on-board solar charging system, which uses solar power to replace battery power consumption (see solar charging section, page 92).

Load Shedding:

Due to the high AC power demand whenever the microwave oven and the air-conditioning unit are simultaneously used, a load shedding circuit is employed which temporarily cuts power to the air-conditioning unit while the microwave oven is in use. Power is automatically restored to the air-conditioner two minutes after the microwave oven is off. This 2-minute delay is necessary to give time for the air-conditioner's compressor pressure to drop to a pre-determined re-starting level.

NOTE: Load shedding is active whether power is being drawn from an external source (shore power) or from the on-board batteries.

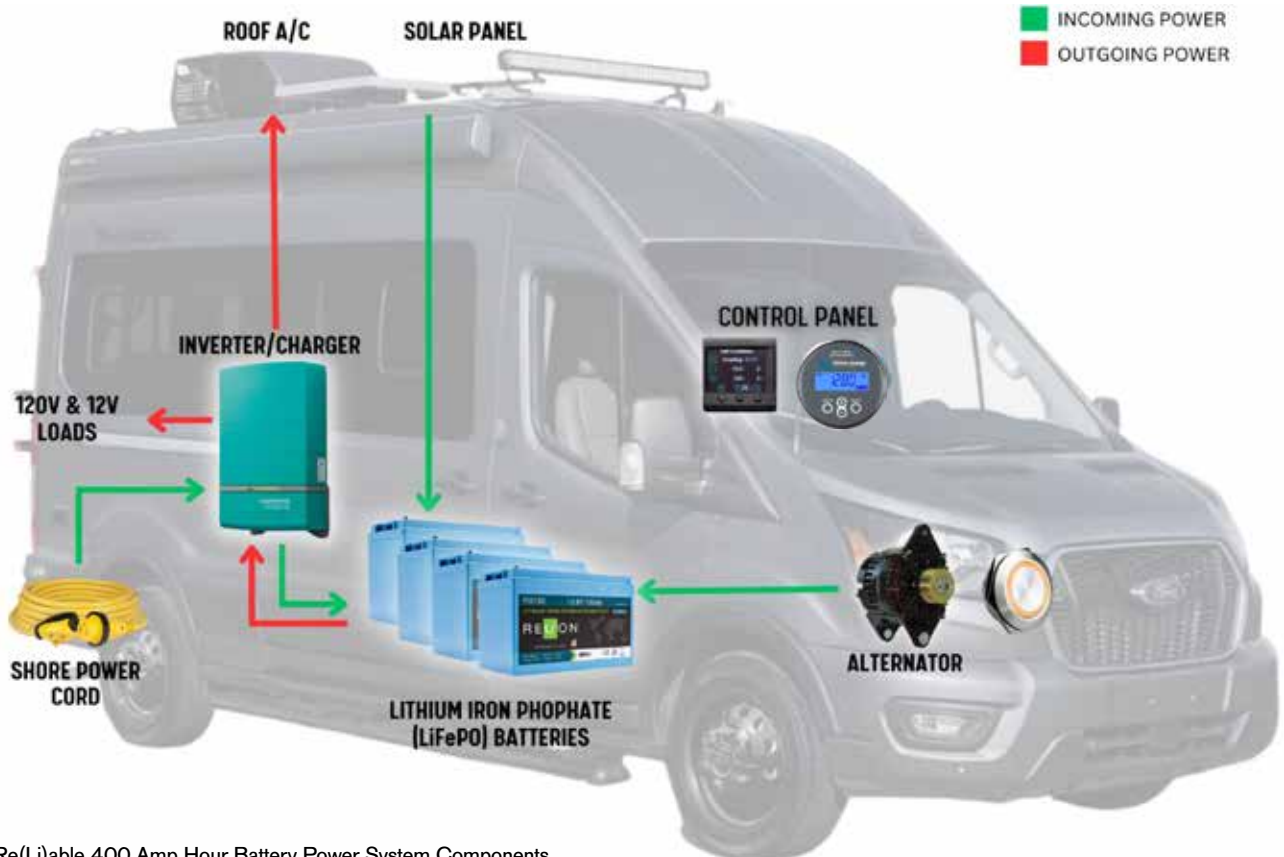

Re(Li)able 400 Amp Hour Battery Power System Components

System Monitoring:

The 200 Ah battery power system includes two devices that provide power monitoring:







- Mastervolt Smart Remote: monitors incoming and outgoing power from the inverter/charger.
- Victron Battery Monitor; monitors the charge and discharge condition of the on-board batteries.



Mastervolt SmartRemote Inverter Monitor and Remote Controller

Operating the Mastervolt Smart Remote Monitor

- Pressing P1 (first button on left) turns the inverter ON/OFF.
- Pressing P2 or P3 reveals sub menus, where adjustments to power sharing and other parameters are made.
- The readout shows the following conditions:

-  Inverter State of Operation:
Inverting/Charging/Standby
-  Battery Voltage or Charging Current
-  Output Power (AC OUT)
-  Shore Power (AC IN)
-  Energy Left in Battery (State of Charge)
-  Time Remaining During Discharge

Display Icons and Meaning

Victron BMV-712 Smart Battery Monitor

See pages 106-109 for additional battery monitor information

The battery monitor displays these important parameters:

- State of charge
- Battery voltage
- Battery current
- Power
- Aux input reading (additional features, such as midpoint voltage or battery temperature)



Victron Energy Battery Monitor

Battery Charging

Shore Power

When parked and connected to shore power, system battery charging is accomplished by the system's inverter/charger. The inverter/charger automatically keeps the battery(ies) in a state of charge by sensing and regulating the charging needs of the battery pack.

Battery charging is augmented by the on-board solar panel and solar charge controller. Solar charging is available whenever the solar controller is ON, independent of the system's inverter/charger and vehicle's alternator output.

IMPORTANT! NEVER SIMULTANEOUSLY CHARGE LITHIUM-ION BATTERIES WITH BOTH SHORE POWER AND THE ENGINE ALTERNATOR. OVERCHARGING CURRENT CAN CAUSE SEVERE BATTERY DAMAGE.

NOTE: The charger section of the inverter/charger is ON whenever connected to a 120 VAC shore power source, providing controlled charging energy to the system's lithium battery(ies).

Stop charge event

When the battery gets too close to the allowed operating specifications, the Stop Charge event forces the Mastervolt charger to switch to the float stage, in which a lower charge voltage is used (or switch off in case of parallel connection). The event will be active for 10 minutes.

Battery Charging While the Vehicle is in Motion

Whenever the vehicle's engine is operating, battery charging for all Re(Li)able lithium battery systems is being provided by a high-output auxiliary alternator, specifically designed to charge the lithium batteries. Charging energy is regulated by a voltage regulator so that excessive battery heat and potential over-charging is prevented. TMC's lithium power systems use the vehicle's engine and the auxiliary alternator as an auto-charging system, while the vehicle is parked and not connected to shore power.

Battery Charging with Solar Energy

Your TMC motorhome is factory-equipped with a solar charging system, which includes a charge controller (stand-alone or remote), a roof-mounted solar panel, and an auxiliary port, which allows the connection of additional portable solar panels (user supplied). This system is designed to provide an alternate battery charging method for your auxiliary lithium battery(ies).

The solar charging system seamlessly integrates with your motorhome's 12-volt DC power system. The auxiliary batteries automatically receive charging energy from the solar panel(s) when the solar charge controller is ON. The solar charge controller provides monitoring of battery condition, monitoring of the charge energy being supplied by the solar panel(s), and regulation of the charging energy; determined by type and charging profile of the auxiliary batteries installed.

When the controller senses that the auxiliary battery(ies) require charging, the controller cycles through multiple stages of charging energy. This multi-stage process is designed to rapidly re-charge the batteries, while protecting the batteries from damage due to over-charging and over-heating.

The maximum current rating of the solar controller installed in TMC Class B motorhomes is 10 amps (incoming energy supplied by the solar panel(s)). The typical factory-installed solar panel for TMC Class B motorhomes is 200 watts (peak power), depending on available roof space. Solar panel(s) installed on your motorhome may vary from these specifications; refer to your Owner's Packet for details. See page 92 for additional solar charging information.

NOTES:

- *Up to 10 amps of charging energy is available through the solar charging system. The solar charging system is designed to augment vehicle and shore power battery charging, whether the vehicle is in motion or parked.*
- *A TMC installed solar charging system is designed and wired to only charge the auxiliary battery(ies). Energy from the solar panel does not directly power 12-volt DC appliances or devices.*
- *Take advantage of adding an additional portable solar panel through the auxiliary solar panel port, typically located along the left side of the motorhome. However, do not exceed the input requirements and limits of the solar charge controller.*
- *Your familiarity and use of the system and the electrical devices of your motorhome will be the best gauge of how long your battery power system will last before requiring a recharge. Using the on-board solar charger whenever possible will add power back to the batteries, prolonging battery power use.*
- *If the battery(ies) have discharged too far, they may enter a 'shut-down' or 'sleep' mode. If the batteries do not seem to be accepting a charge, press and hold the Emergency Start Switch for several seconds. Doing so provides voltage to the charging alternator's voltage regulator so that the alternator will begin to provide charging energy to the batteries.*
- *Another method of 'waking up' batteries that have discharged too far is to connect to shore power. This will turn-on the battery charger, providing charging energy to the batteries.*

Battery Storage

Storage Conditions:

The manufacturer recommends storing LiFePO4 batteries at a 50% State of Charge (SOC). If batteries are stored for long periods of time, cycle the batteries (discharge/re-charge) at least once every 6 months.

Storage Temperature:

LiFePO4 batteries can be stored between 23° F to 95° F (-5° C to 35° C). For storage longer than 3 months, the recommended temperature range is 32° F to 77° F (0° C to 25° C).

NOTE: To date, the 400 Ah system is only available from TMC as standard equipment in Ford Transit van-based Class B motorhomes and optional equipment in Ram 3500 van-based Class B motorhomes.

Victron Energy Battery Monitor

⚠ CAUTION

Lithium batteries can be irreparably damaged due to very deep discharge or overcharge. Damage due to deep discharge can occur if small loads slowly discharge the battery when the system is not in use.

The battery monitor draws < 12mA from the battery. The positive supply must therefore be interrupted (disconnected) if a system with Li-ion batteries is left unattended during a period long enough for the battery monitor's power consumption to completely discharge the battery.

In case of any doubt about the possible residual current draw, isolate the battery by turning OFF the master battery switch, by pulling the battery fuse(s) and circuit breakers, or by disconnecting the battery positive terminal connections when the system is not in use.

The battery monitor included with lithium-ion battery systems installed in TMC's Ford Transit-based Class B motorhomes is supplied by Victron Energy, model BMV-712-Smart. This monitor is Bluetooth enabled, meaning that when the VictronConnect App is installed on your smartphone, battery monitoring, settings adjustments, along with other features, are viewable and controllable via your smartphone. Following, is a brief description of this battery monitor, its function and operation.

The main function of the battery monitor is to indicate the state of charge (SOC) of the auxiliary battery, indicate how much charge the battery contains, and to prevent an unexpected total discharge. The battery monitor continuously measures the current flow in and out of the battery, giving the operator a good indication of the discharge rate and the charging rate of the battery at any given time and given the electrical load (lights, appliances, etc.) on the battery.

The effective capacity of a battery depends on the rate of discharge, its internal resistance and chemistry, and, to a lesser extent, the ambient temperature. Due to inherent factors of the battery's composition, at any given level of State of Charge (SOC), it takes more charging energy going into a battery than the available discharge energy, meaning the charge efficiency is less than 100%. The battery monitor takes all these factors into consideration when calculating the state of charge.

NOTE: Most lithium-ion batteries contain internal protection that 'turns off' the battery whenever it reaches a certain low energy condition, protecting the battery from irreversible damage. Refer to battery manufacturer's information manual available through your TMC Owners Resource account.

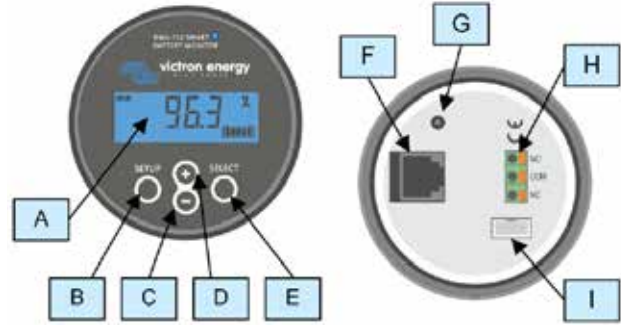

Battery Monitor Display and Connections	
A	Main Display
B	Setup Button
C	Down Button
D	Up Button
E	Select Button
F	RJ12 Connector
G	Buzzer
H	Programmable Relay Connection
I	VE Direct Connection

VictronConnect App.

The VictronConnect App. can be used to monitor and configure the battery monitor. Note that configuring the battery monitor using the VictronConnect App. is easier than configuring using the battery monitor head unit.

The VictronConnect App. can connect to the battery monitor via:

- Bluetooth
- USB, using the optional VE.Direct to USB interface
- Remotely via a GX device and the VRM portal

The VictronConnect App. is available for the following platforms:

- Android.
- Apple iOS (Note that USB is not supported, it is only possible to connect via Bluetooth).
- MacOs.
- Windows (Note that Bluetooth is not supported, it is only possible to connect via USB).

The VictronConnect App. can be downloaded from app stores or from the VictronConnect product page.

How to connect with the VictronConnect App. to the battery monitor:

- Open the VictronConnect App.
- Ensure that the battery monitor is powered.
- Look for the battery monitor to appear in the device list in the "Local" or the "VRM" tab.
- Click on the battery monitor.
- In case of a connection via Bluetooth; enter the default PIN code: 000000. After entering the default PIN code, the VictronConnect App. will ask you to change the PIN code. This is to prevent unauthorized connections in the future. This can be done in the product info tab; see 'Changing PIN Code' section of the manufacturer's owner's manual.

-  To view and/or change battery monitor settings, navigate to the settings page by clicking on the cog icon at the top right of the home screen.

Available Information From the BMV-712-Smart Monitor

State of charge:

This is the actual state of charge of the battery in a percentage and is compensated for the charge efficiency of the battery. The state of charge is the best indication of the amount of energy contained in the battery at any given time. A fully charged battery will be indicated by a value of 100.0%. A fully discharged battery will be indicated by a value of 0.0%.

Please note that if the 'State of Charge' is indicated by three dashes: "---" this means that the battery monitor is in an unsynchronized state. This mainly occurs when the battery monitor has just been installed or after the battery monitor has been left unpowered and is powered up again. For more information, see the 'Synchronizing the battery monitor,' section of the manufacturer's owner's manual.

Voltage:

This is the terminal voltage of the battery.

Current:

This is the actual current flowing in or out of the battery. A negative current indicates that current is taken from the battery. This is the current needed for DC loads. A positive current means that current is going into the battery. This is current coming from charge sources. Keep in mind that the battery monitor will always indicate the total battery current, being the current traveling into the battery minus the current traveling out of the battery.

Power:

The power drawn from or received by the battery.

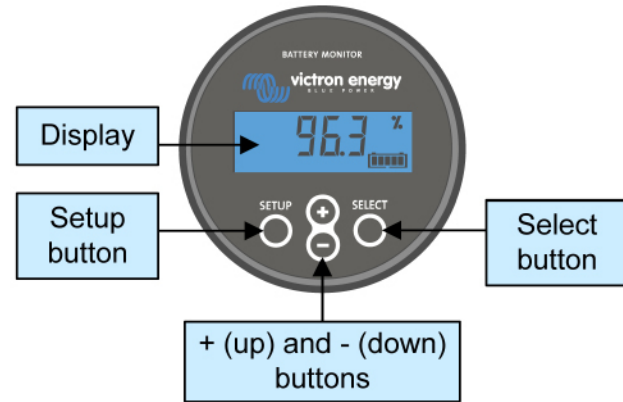

To access the settings menu and change settings:

1. Start in the main menu.



2. Press SETUP for two seconds to enter the settings menu.



3. The first settings item 01-Battery capacity will be shown.



4. Use the + and - buttons to go to the desired setting item.



5. Press SELECT to access the settings item.



6. Use SELECT and the + and - buttons to customize the setting.



7. Press SETUP to return to the settings menu.



8. Go to the next setting using the + or - buttons.



9. After all settings have been made, press SETUP to return from the settings menu to normal mode.



Consumed Ah:

The battery monitor keeps track of the Amp-hours removed (discharged) from the battery, compensated for charge efficiency.

Example: If a current of 12 A is drawn from a fully charged battery for a period of 3 hours, the readout will show -36.0 Ah ($-12 \times 3 = -36$).

Please note that if the 'Consumed Ah' reading indicates three dashes: "---" this means that the battery monitor is in an unsynchronized state. This mainly occurs when the battery monitor has just been installed or after the battery monitor has been left unpowered and is powered up again. For more information, see the 'Synchronizing the Battery Monitor,' section of the manufacturer's owner's manual.

Time remaining:

The battery monitor estimates how long the battery can support the present load. This is the 'time-to-go' readout and is the actual time left until the battery is discharged to the set 'discharge floor.' The discharge floor is by default set at 50%. For the discharge floor setting see the 'Discharge Floor' section of the manufacturer's owner's manual. If the load is fluctuating heavily, it is best not to rely on this reading too much, as it is a momentary readout and should be used as a guideline only. Use the 'State of Charge' readout for accurate battery monitoring.

If the 'Time remaining' indicates three dashes: "---" this means that the battery monitor is in an unsynchronized state. This occurs when the battery monitor has just been installed or after it has been left unpowered and is powered up again. For more information, see the 'Synchronizing the battery monitor,' section of the manufacturer's owner's manual.

Input:

This is the state of the auxiliary input. Depending on how the battery monitor has been set up, you will see one of these options:

- **Starter battery voltage:** This shows the voltage of a second battery.
- **Battery temperature:** This shows the battery temperature of the lithium battery(ies) when the optional temperature sensor is used.
- **Midpoint voltage deviation:** This shows the deviation in a percentage of the main voltage of the battery bank top section compared to the voltage of the bottom section. For more information on this feature see the 'Midpoint Voltage Monitoring' section of the manufacturer's owner's manual.

NOTE: For additional information on the BMV-712 Smart Battery Monitor, visit the manufacturer's website or view the owner's manual from your TMC Owners Resource account.

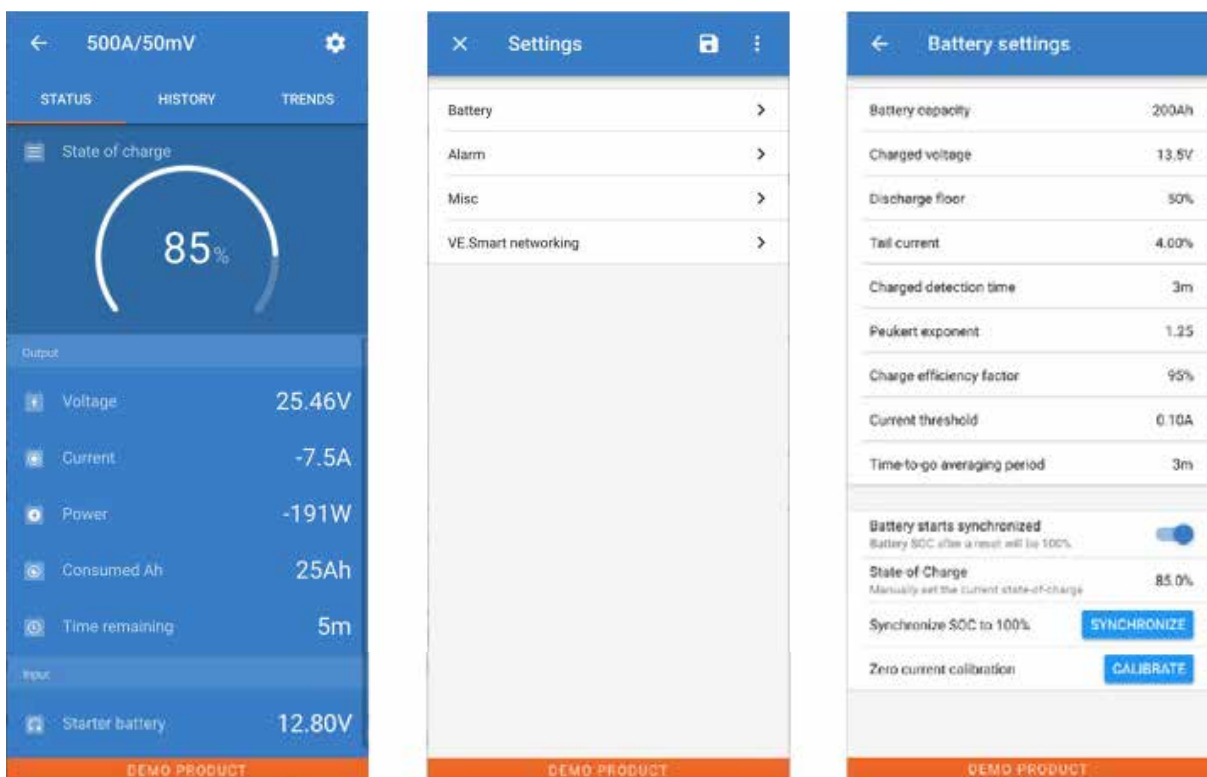

The battery monitor, monitoring, and setting screens in the VictronConnect app.

Ford Transit Vans Only: Idle Speed Control

⚠ WARNING

- There is a dangerous potential of exhaust gases entering the motorhome whenever the vehicle is parked and the engine is running.
- Avoid inhaling exhaust gases as they contain carbon monoxide, which is a toxic gas that is colorless and odorless.
- Never sleep or allow others to sleep in a parked vehicle while the engine is running.
- Test the CO/LP detector and ensure it is operational.
- Do not engage Elevated Idle Speed Control if the vehicle is parked in an enclosed building or confined space.
- Before engaging the Elevated Idle Speed Control, ensure the vehicle's exhaust system is free of obstructions.

⚠ WARNING

NEVER SIMULTANEOUSLY CHARGE A BATTERY FROM SHORE POWER AND THE ENGINE ALTERNATOR:

EXCESSIVE CHARGING ENERGY WILL RESULT IN BATTERY DAMAGE.

NOTICE

— FORD TRANSIT VANS ONLY! —

BATTERY CHARGING VIA THE AUXILIARY ALTERNATOR

Under normal driving conditions, the auxiliary alternator will provide adequate charging energy (voltage) to recharge the power system's lithium-ion batteries. However, when parked and with a warm engine running, the normal low engine idle speed of Ford Transit vans will not allow the auxiliary alternator to generate adequate charging energy.

Therefore, when the vehicle is parked, and it becomes necessary to operate the engine to charge the lithium batteries, press the ELEVATED IDLE SPEED CONTROL SWITCH (or SEIC Switch), mounted on the vehicle's dash panel. Doing so, increases the engine idle speed, thus allowing the auxiliary alternator to generate adequate energy to charge the lithium batteries.

All TMC Ford Transit-based Class B motorhomes (Palladium and Talavera models) are equipped with a manual (driver activated) Elevated Idle Speed Control Switch. This switch is located next to the Emergency Start Switch (for E-Start operation, refer to page 91).

IMPORTANT! NEVER SIMULTANEOUSLY CHARGE LITHIUM-ION BATTERIES WITH BOTH SHORE POWER AND THE ENGINE ALTERNATOR. OVERCHARGING CURRENT CAN CAUSE SEVERE BATTERY DAMAGE.

The Elevated Idle Speed Control Switch provides for the selection of three engine idle speeds:

- **Elevated:** approximately 850 RPM
- **High Idle:** approximately 1,500 RPM
- **OFF:** normal warm engine idle is approximately 650 RPM (center switch position)

To activate Elevated or High Idle, the following pre-operating parameters must be met:

- Vehicle speed is 0 MPH (stationary)
- Vehicle transmission in PARK
- Park brake applied
- Foot off of service brake
- Foot off of accelerator pedal
- Engine running at a stable base idle speed
- Engine Coolant Temperature (ECT) 40°F minimum

NOTE: Elevated idle will not engage until all pre-operating parameters are met.

Operating the Elevated Idle Control

1. Start the vehicle's engine and allow a brief warm-up.
2. Ensure all pre-operating parameters are met (listed above). The Elevated Idle Control will NOT engage until the engine reaches normal low idle speed.



Ford Transit Idle Speed Selection Switch

3. Press either the Elevated Idle or High Idle switch position. The LED on the switch panel will light, indicating elevated idle speed system activation.

The engine's RPM will noticeably increase, allowing the auxiliary alternator to generate enough energy to charge the lithium-ion battery pack(s).

NOTE: Faster charging will be realized with the High Idle position.

4. Monitor the battery condition (State of Charge, or SOC) on the Victron battery monitor.
5. When the lithium-ion battery pack has reached an adequate state of charge, turn off the vehicle's engine. With the engine OFF, the idle speed control will automatically reset to normal operation.

Conditions that will Deactivate Elevated Idle Control: The Elevated Idle Control System will automatically deactivate whenever any of the following conditions is encountered:

- The Parking Brake is disengaged;
- The Service Brake is depressed;
- The vehicle's transmission is taken out of PARK;
- The engine management system senses too high;
 - › Engine coolant temperature, or
 - › Transmission oil temperature, or
 - › Catalytic converter temperature.

NOTE: If a system deactivation event occurs or the system fails to activate, the engine must be allowed reach a stable and normal idle speed before re-activation can occur. This usually takes 15-30 seconds. Place the Elevated Idle Switch in the OFF position, wait 30 seconds, make sure all the pre-operating vehicle parameters are met, then re-engage the Elevated Idle Control.

Approximate Charging Times:

Approximate system charging times is dependent on several factors; the State of Charge (SOC) of the battery packs, whether there is a load on the battery pack, i.e., lights or appliance turned ON, ambient and battery temperature, age of batteries, etc.

However, at elevated engine idle speed (850 RPM), the auxiliary alternator will deliver approximately 100 amps of charging energy. For a fully depleted 400 Ah battery system, it would take approximately 4 hours to fully charge the battery pack.

At high engine idle speed (1,500 RPM), the auxiliary alternator will deliver approximately 150-amps of charging energy. It would take approximately 2.5 hours to charge a fully depleted 400 Ah battery pack.

Tips for Battery Charging and Elevated Idle Control System Use:

Use good judgement when using the Elevated Idle Control System:

- Always be extremely cautious of exhaust gases whenever parked and while the vehicle's engine is running (see Warning at the beginning of this section).
- Extended periods of engine idling presents certain operational wear to the engine and engine components.
- Always take advantage of the factory installed solar charging system; doing so can reduce charging times. Your Class B motorhome is also equipped with an auxiliary port designed to connect a portable solar panel (owner supplied) to the solar charger. Taking advantage of this feature can provide additional charging energy, however not beyond the maximum output limits of the solar controller.
- Use shore power for charging whenever available.
- When driving the vehicle, always keep the master battery switch ON. This allows charging from the auxiliary alternator while the vehicle is in motion.
- Use appliances and electric devices prudently. Doing so will help reduce battery system energy consumption.

Re(Li)able® V1, 460 Amp-Hour System

NOTE: The master battery switch must be ON to operate the electrical devices of your motorhome; whether electrical power is being supplied by shore power or by the lithium-ion battery system.

Shore power:

When shore power is available, 120-volt AC electrical devices installed in the motorhome are powered by the external AC source. Incoming AC is passed through the system's inverter/charger, via an internal transfer switch, then out to an on-board fuse/breaker panel, and to the circuits in which the electrical devices of the motorhome are connected. 12-volt DC powered devices, such as internal lights, awnings, water pump, and furnace blower are powered by the system's lithium batteries. At the same time 12-volt electrical power is being drained from the battery(ies), the battery(ies) are receiving recharging energy from the charger section of the inverter/charger. The on-board solar charging system will also supply restorative energy to the batteries whenever the solar controller is ON and weather conditions are favorable for solar energy generation.

If the AC load demand is high, the circuits in the inverter/charger automatically reduce the power going to charge the batteries, therefore making more energy available for the motorhome's AC powered devices (up to the full amperage of the incoming source).

If the AC load is still above the energy supply potential of the incoming AC source, the inverter/charger will automatically augment the AC supply by providing additional AC power from the system's batteries via the inverter.

NOTE: the AC load of the motorhome should never exceed 40 amps. Exceeding 40 amps could damage the inverter/charger.

Off-the-grid power:

When shore power is not available or not detected by the transfer switch, the on-board lithium battery system provides the power for all 120-volt AC and 12-volt DC devices. 12-volt DC-powered devices are powered directly by the on-board lithium battery pack, while the 120-volt AC devices (mainly the microwave oven, air-conditioner, TV, and other entertainment devices) are powered by the 3,000 watt inverter, which converts 12-volt DC battery power to 120-volts AC.

While operating the electrical devices of the motorhome strictly by the battery power system, being mindful of electrical loads and power demands becomes very important. Due to the limited availability of power from the on-board battery (460 Ah maximum from fully charged battery pack), one should always be conservative with power use whenever shore power is not available.

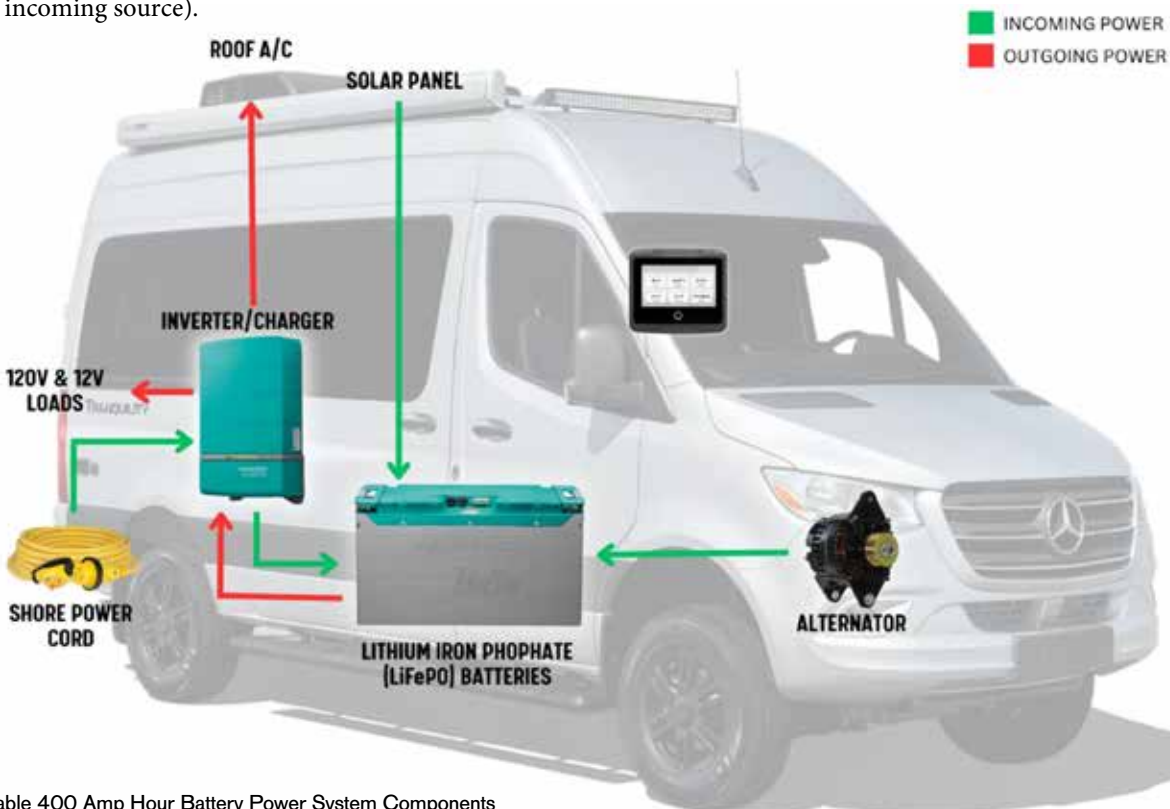

Re(Li)able 400 Amp Hour Battery Power System Components

NOTES:

- The electrical load of an air-conditioner can be significant. When not connected to shore power, turn off the AC while away from your motorhome for an extended period of time. This will significantly prolong battery life between charges.
- When operating off-the-grid, always take advantage of the on-board solar charging system, which uses solar power to replace battery power consumption (see solar charging section).

Load Shedding

Due to the high AC power demand whenever the microwave oven and the air-conditioning unit are simultaneously used, a load shedding circuit is employed which temporarily cuts power to the air-conditioning unit while the microwave oven is in use. Power is automatically restored to the air-conditioner two minutes after the microwave oven is off. This 2-minute delay is necessary to give time for the air-conditioner's compressor pressure to drop to a pre-determined re-starting level.

NOTE: Load shedding is active whether power is being drawn from an external source (shore power) or from the auxiliary batteries.

Mastervolt EasyView 5 System Controller

The system has a user-interface control panel; mounted near the sliding door entrance of the motorhome (location may vary depending on model).



Illustration of Mastervolt control panel in the battery monitor mode

1. Remove the protective cover to access the control screen.
2. Locate and hold the home button. After a few moments, the control panel screen will turn ON, displaying the system's monitoring screen.
3. To turn OFF the control panel, hold the home button for approximately 3 seconds; an option screen will appear. Select Lock, Stand by, or Off.



System Control Panel



Home button on System Control Panel

Screen navigation:



Illustration of Lock, Standby, and Off control features

Navigate to another page by swiping or by tapping the left or right bottom of the screen. The bullets on the bottom of the display show how many pages are in the menu selection and which page of the sequence is being displayed. Soft buttons located along the top of the touchscreen allow navigation to other menu screens.



Swiping and tapping to change screen views

NOTE: Refer to the manufacturer's instructions regarding system configuration, operation, and fault codes displayed by the control panel.

Safety Relays

WARNING

If a non-resettable BATTERY SAFETY event occurs; set the safety relay(s) to LOCK OFF and contact a service representative for assistance. Refer to the manufacturer's instruction manual for further information.

IF THE SAFETY RELAY HAS BEEN TRIGGERED:

1. On the MasterBus control panel, check that the voltage is within limits; between 10V and 15.5V.
2. If within limits, click the CLOSE RELAY button on the MasterBus control panel. Start charging if voltage is Low (10V) or discharging when high (15.5V).
3. If Relay trips again, Isolate battery and contact a manufacturer's (Mastervolt) representative.

Located inside or underneath the vehicle (location varies due to floor plan design) is a Battery Safety Relay or relays. There is one relay for each Mastervolt battery pack installed. In order to draw power from the battery packs AND provide charging to the lithium-ion battery system, the safety relays must be in the ON position and latched. As these safety relays also act as a power disconnect for the battery packs, place the safety relays in the OFF position whenever servicing the lithium-ion system is required or when taking the lithium-ion system out of service (such as placing the vehicle in storage).

NOTE: Safety Relays are not used with TMC 200 Ah, 300 Ah, and 400 Ah battery power systems. There is one safety relay for each Mastervolt lithium battery pack. 460 Ah systems will have one safety relay, while 920 Ah systems will have 2 safety relays.



Safety Relays for the Lithium-ion Battery System



Safety Relay in the OFF position



Safety Relay rotated to the ON position. Depress the center to engage the safety relay



Safety Relay engaged, turning ON the battery pack

Turning the safety relays ON:

1. Rotate both yellow switch knobs to the left (ON position).
2. Depress the center of the knob to engage the safety relay (powering the battery system).

Turning the safety relays OFF:

Rotate the yellow knob to the right (OFF position). The center of the knob should automatically pop-out.

Resetting a tripped safety relay:

If the battery system has shut-off and the safety relay(s) are tripped:

1. Turn OFF all 120-volt appliances (air-conditioner, appliances, etc.) and disconnect appliances from the 120-volt AC receptacles.
2. Press the center of the yellow knob to re-set the safety relay. If the safety relay does not latch, do not force it. The lithium-ion battery system will need repairs.

NOTE: If you do not have power and the safety relays are NOT tripped:

- Check that the master battery switch is ON.
- Check that the power switch on the Inverter/Charger is OFF; it should be kept in the OFF (O) position (enabling remote switching by the master battery switch).
- Check the battery charge condition on the Mastervolt control panel. It is likely the battery packs need re-charging.

Battery Safety Event:

A battery safety event triggers the safety relay to automatically disconnect the battery from the loads and charging devices. There are two kinds of battery safety events: a resettable and a non-resettable.

A resettable safety event occurs if one of the following conditions is met for 10 seconds:

- The battery voltage is less than 10.0V (12V battery) or 20.0V (24V battery);
- The battery voltage is more than 15.5V (12V battery) or 31.0V (24V battery);
- The voltage of one of the individual cells inside the lithium-ion battery is too high or too low (2.5V / 4V for 10 sec or 2V / 4.2V for 1 sec);
- The internal temperature of one of the individual cells is too high (>85°C).

This event is repeated every 60 seconds. It will only stop repeating if the battery voltage returns and remains within specifications, i.e., 10.0-15.5V (12-volt battery) or 20.0-31.0V (24 volt battery).

A non-resettable safety event occurs if one of the following conditions is met for 10 seconds:

- The battery voltage is less than 9.0V (12-volt battery) or 18.0V (24 volt battery);
- The battery voltage is more than 16.0V (12-volt battery) or 32.0V (24 volt battery);
- The voltage of one of the individual cells inside the lithium-ion battery is too high or too low (5V / 1.5V for 1 sec);
- The internal temperature of one of the individual cells is too high (>90°C).

Battery Charging

Shore Power:

When parked, charging is accomplished whenever shore power is connected (by the system's inverter/charger). The inverter/charger automatically keeps the battery(ies) in a state of charge by sensing and regulating the charging needs of the battery pack.

Battery charging is augmented by the on-board solar panel and solar charge controller. Solar charging is available whenever the solar controller is ON, independent of the system's inverter/charger or vehicle's alternator electrical output.

IMPORTANT! NEVER SIMULTANEOUSLY CHARGE LITHIUM-ION BATTERIES WITH BOTH SHORE POWER AND THE ENGINE ALTERNATOR. OVER-CHARGING CURRENT CAN CAUSE SEVERE BATTERY DAMAGE.

Stop charge event:

When the battery gets too close to the allowed operating specifications, the Stop Charge event forces the Mastervolt charger to switch to the float stage, in which a lower charge voltage is used (or switch off in case of parallel connection). The event will be active for 10 minutes. Refer to the manufacturer's information provided in your Owner's Packet, for safety, operational, charging, and maintenance details. System information is also available through the TMC Owners Resource:

<https://www.thormotorcoach.com/owners/>

Battery Charging While the Vehicle is in Motion:

Whenever the vehicle's engine is operating, battery charging for all lithium battery systems is being accomplished by a high-output alternator, specifically designed to charge the lithium batteries while the vehicle is in motion. Charging energy is regulated by the inverter/charger so that excessive battery heat and potential over-charging is prevented. Select lithium power systems use the vehicle's engine and this additional alternator as an auto-charging system, while the vehicle is parked and not connected to shore power.

Charging Extremely Cold Lithium Battery(ies):

An extremely cold lithium-ion battery(ies) can be severely or permanently damaged if a high charge current is introduced before the battery has been sufficiently warmed up. This is the reason that many lithium batteries are equipped with internal heating elements. When conditions of an extremely cold battery are encountered, such as if the motorhome is to be moved or used when the ambient temperature is below 32°F (0°C), using the engine and alternator for charging could introduce too high of a charge current.

In these situations, it is best to use shore power and the CombiMaster Inverter/Charger to charge the lithium-ion battery(ies) because this 'smart' charger will sense the battery temperature and limit charging amperage until the battery has warmed sufficiently to be able to accept higher rates of charging energy.

Charging Extremely Hot Lithium Battery(ies):

Extreme hot conditions can also negatively affect lithium batteries. A lithium-ion battery should never be charged if its temperature is above 122°F (50°C). If the battery is outside of its normal operating temperature, 32°F - 122°F (0°C - 50°C), and a safety relay is installed, it is likely that the safety relay will trigger, thus preventing damaging charging energy to reach the battery.

Allow the battery to normalize within the operating temperature range and reset the safety relay (if tripped). Then, attempt to charge the battery by using shore power (if available) or by the auxiliary alternator.

NOTES:

- *Up to 10 or 30-amps of charging energy is available through the solar charging system. The solar charging system is designed to augment vehicle and shore power battery charging, whether the vehicle is in motion or parked. For additional information, refer to the Solar Charging section, beginning on page 92.*
- *A TMC installed solar charging system is designed and wired to only charge the auxiliary battery(ies). Energy from the solar panel does not directly power 12-volt DC appliances or devices.*

- Take advantage of adding an additional portable solar panel through the auxiliary solar panel port, typically located along the left side of the motorhome. However, do not exceed the input requirements and limits of the solar charge controller.
- Your familiarity and use of the system and the electrical devices of your motorhome will be the best gauge of how long your battery power system will last before requiring a recharge. Using the on-board solar charger whenever possible will add power back to the batteries, prolonging battery power use.
- If the battery(ies) have discharged too far, they may enter a 'shut-down' or 'sleep' mode. If the batteries do not seem to be accepting a charge, it is likely that the safety relay has opened. First, connect to shore power, then press the center of the yellow knob to close the Safety Relay. The battery should now be able to accept a charge from the inverter/charger.
- If the battery still refuses to accept a charge, contact Mastervolt's Customer Service; a technician might need to remote-in to the MasterBus and run a diagnostic test on the system. Often, the technician can remotely 'awake' a battery.

Battery Storage

Storage Conditions:

If the LiFePO4 battery(ies) will not be used for a period exceeding 3 months, the manufacturer recommends:

- If an external AC power source is available, Switch off all loads and switch on the Mastervolt Inverter/Charger. The charger will maintain a proper float charge.
- IF an external AC power source is NOT available:
 - › Charge the battery(ies) to > 80% of capacity before storage
 - › Set the safety relay knob to 'LOCK OFF'

In this setup the battery(ies) can be kept at least 6 months without maintenance. However, it is highly recommended to charge the battery(ies) to > 80% of their capacity every 100 days.

Storage Environment:

LiFePO4 batteries can should be stored in a dry and well ventilated environment. Storage temperatures can range from -13°F to 122°F (-25°C to 50°C). However, temperatures below 41°F (5°C) and above 77°F (25°C) may affect battery lifetime and cycle life.

NOTE: For long-term storage of lithium-ion battery systems, see information beginning on page 119.

Engine Auto-Start Charging System (optional)

WARNING

- There is a dangerous potential of exhaust gases entering the motorhome whenever the vehicle is parked and the engine is running.
- Avoid inhaling exhaust gases as they contain carbon monoxide, which is a toxic gas that is colorless and odorless.
- Before engaging the auto-start charging system, ensure the vehicle is parked in an open area and that the vehicle's exhaust system is free of obstructions.
- Do not engage auto-start charging if the vehicle is parked in an enclosed building or confined space.
- Test the CO/LP detector and ensure it is operational.
- Never sleep or allow others to sleep in a parked motorhome while the engine is running.
- Do not engage auto-start charging if connected to shore power.

Select Re(Li)able battery systems may include an auto-start module (not available with Sprinter-based Class B motorhomes) that when enabled, monitors the lithium-ion battery's state-of-charge. When the state-of-charge falls below a pre-determined set-point, the module will automatically start the vehicle's engine, providing charging to the battery pack(s) via the auxiliary alternator. While engine is running the module continues to monitor the battery's state-of-charge, and when the battery pack reaches a pre-determined charged level; the module will automatically stop the engine.

NOTE: The auto-start charging feature is intended for off-the-grid use only and should never be engaged while the vehicle is connected to shore power. Over-charging energy could occur, which can severely damage the lithium-ion battery pack(s).

NOTE: This feature is optional and may not be available on Sprinter-based motorhomes.



Auto-Start Control Button, located left of the steering wheel (RAM)

Enabling the Auto-Start Module

Monitor mode:

For the auto-start module to control engine start/stop, it must first be in 'Monitor Mode.' Before entering Monitor Mode, these pre-conditions must be met:

- Vehicle is in park;
- Vehicle's driving brakes are NOT engaged;
- Parking brake engaged;
- Hood closed (engine compartment) ;
- Fuel level above 1/4 tank;
- Ignition switch in the RUN position.

With these pre-conditions met, Monitor Mode is entered by pressing and holding the control button (located on the driver's side of the dashboard) for a pre-programmed amount of time. The control button LED turns ON as a visual indication. As long as Monitor Mode is active, the LED remains ON. The key can be removed from the ignition after entering Monitor Mode.

Upon entering Monitor Mode the instrument cluster will turn ON, a 30-second timer will start, and the Auto-Start Module will monitor the lithium-ion battery's state-of-charge. If battery state-of-charge remains above the 'trip-point,' and the 30-second timer expires, the system will turn OFF the instrument cluster and continue to monitor the battery state-of-charge. Once the battery state-of-charge drops below the 'trip-point,' the system will turn ON the instrument cluster and auto-start the vehicle's engine (on high-idle) as normal.

The vehicle's engine will run until the lithium-ion battery reaches 80% charge.

Monitor LED:

A continuously-lit LED indicates normal monitoring operation. If the LED is blinking, either an error has occurred or an unwanted operational condition has been detected. Three possible errors are:

- Engine failed to start after 3 tries;
- Engine failed to stop after 3 tries;
- Engine prematurely stopped.

For each of these circumstances, auto-start/stop function is disabled until Monitor Mode is reset (exiting, then re-entering). A forth case which temporarily disables auto-start/stop is if the vehicle's brakes are applied while in Monitor Mode. In this instance, auto-start/stop is again disabled, for a period of time, before automatically returning to normal Monitor Mode operation.

Exiting monitor mode:

Exiting Monitor Mode is accomplished by:

1. Releasing the parking brake, or;
2. Pressing the FOB 'Unlock' button 3 times;
For these two actions:
 - a. If the engine is running, the module will turn OFF the engine, then exit Monitor Mode (indicated by the LED turning OFF).
 - b. If the engine is not running, Monitor Mode is simply exited (indicated by the LED turning OFF).
3. Or by inserting the key in the ignition and turn it to the START position.
 - a. If the engine is running, the module exits Monitor Mode (indicated by the LED turning OFF).
 - b. If the engine is not running, the module exits Monitor Mode without starting the engine (indicated by the LED turning OFF).

NOTE: Once Monitor Mode is exited, the auto-start module is disabled. Monitor Mode must be re-entered in order to enable the auto-start module.

Battery Force Charging:

While in Monitor Mode, an additional feature allows the user to activate the engine on high-idle, enabling faster charging of the batteries. If the module is in Monitor Mode:

1. Press the activate/deactivate button three times within 3 seconds; at which time, the vehicle's engine will start and run on high idle speed.
2. The engine will continue to run on high idle until the lithium-ion battery system is fully charged and then auto-shut off the vehicle's engine as normal.

NOTE: Consult the manufacturer's instructions for full details regarding the safety and operational details of the auto-start/stop charging system. Manufacturer's information is available through TMC's on-line Owners Resource:

<https://www.thormotorcoach.com/owners/>

Module Configuration (Factory settings)

The operational aspects of the WIN752 are defined/controlled with the use of several parameters. Each has a pre-programmed value stored in non-volatile memory. Any of these values can be modified in the field with the use of an Intermotive download cable and a laptop running a terminal emulator application.

This laptop/download cable combination is also used to update firmware in the field. Contact Intermotive to order a download cable if required.

The following parameters are available for modification:

- **OEM low voltage trip point:** Engine auto starts when OEM battery falls to this level. Default value is 11.9V. Range is 8V to 15V.
- **OEM charge restore point:** When voltage level is reached, module will start an extended timer. Default value is 13.5V. Range is low limit to 15V.
- **Extended charge time:** How long engine continues to run after OEM restore point is reached. Default value is 1200 sec. Range is 10 to 3600 sec.
- **High Idle engine speed:** Default value is 1600 RPM. Range is 950 RPM—2000 RPM.
- **Engine Over Rev:** Special output goes active when this value is exceeded. Default value is 3700 RPM. Range is 2000 to 4500 RPM.
- **Monitor Mode lockdown time:** When in Monitor Mode a temporary lockout occurs if service brake is applied, disabling auto-start/stop; this time determines how long before the module reverts back to normal Monitor Mode with auto-start/stop functions restored. Default value is 300 seconds. Range is 10 - 600 seconds.
- **Push Button Latency:** Button must be held at least this long before it takes effect. Default value is 2 seconds. Range is 2 seconds to 10 seconds.
- **Maximum ECT:** Maximum coolant temperature beyond which high idle ceases to operate. Default value is 106° C (219° F). Range is 65° C to 110° C (149° F — 230° F).
- **Minimum ECT:** Coolant temperature must be at least this value before high idle will operate. Default value is 0° C (35° F). Range is 0° C to 15° C (32° F — 59° F).
- **Toggle Crank feature ON/OFF:** If enabled, the Over-Rev output will be active during crank.
- **Auxiliary Battery low voltage trip point:** Engine auto starts when auxiliary battery falls to this level. Default value is 49.9V. Range is 40V to 60V.
- **Auxiliary Battery charge restore point:** When voltage level is reached, module will auto-stop the engine. Default value is 57V. Range is low limit to 60V.

- **Low Fuel Level threshold value:** If fuel level on vehicle is below this value, system will not enter monitor mode. Default value is 25% of full tank. Range is 0-100%
- **Engine-Run Time-out Value:** Maximum allowable time engine will run on a single auto-start event. Default time is 60 minutes. Range is 50—120 minutes.

Using a laptop and download cable, a configuration menu is available and can be used to make changes to any of the previous parameters. Contact the module's manufacturer for further instructions on how to make configuration adjustments.

NOTES:

- *Consult the manufacturer's instructions for full details regarding the safety and operational details of the auto-start/stop charging system.*
- *The Auto-Start Charging system does not replace the manual engine charging method described on page 109. Ford Transit vans are equipped with both the manual Engine Idle Speed Control (used for manually charging the battery pack(s) via the auxiliary alternator) and the Intermotive auto-start module described in this section.*
- *RAM ProMaster and Mercedes-Benz Vans do not require the manual Engine Idle Speed Control because normal idle speeds allow the auxiliary alternator to produce adequate charging energy.*

MasterAdjust Software and Remote System Servicing - 460 Ah System

There may be times when the Mastervolt battery system needs to be adjusted by a Mastervolt service technician. This may be required:

- System software updates.
- System monitoring.
- System configuring, such as adding an additional battery pack or replacing a system component.
- System troubleshooting.
- Retrieval of historical data regarding the original installation.
- The battery pack(s) have become too far discharged so that normal 're-awaking' procedures are ineffective.

To access these features, the MasterAdjust software is needed, along with a MasterBus-USB interface. The MasterBus-USB interface provides a communications link between a PC (with the MasterAdjust software installed) and the battery system's MasterBus (MasterBus is the communications network for the battery system's components).

Mastervolt's MasterAdjust software is available as a free download through the Mastervolt website:

www.mastervolt.com

If an owner downloads the software and connects their PC to the MasterBus (via a standard USB cable), it is possible that a Mastervolt technician can remote-into the user's battery system for the purpose of servicing the system, by remoting into the user's PC (connected to the MasterBus and a WiFi network).

Doing so may save the user a service trip to their local RV dealership (however, service charges may be incurred by Mastervolt).

Contact Mastervolt Customer Service for details:

<https://www.mastervolt.com/technical-support-new/>

or

<https://www.mastervolt.com/contact-form/>

NOTE: Due to the built-in MasterBus contained in the Mastervolt MLI Ultra battery pack, it is only possible to remote-service the Re(Li)able V1, 460 Ah Lithium Battery System.

NOTE: Refer to the manufacturer's instructions regarding system configuration, operation, and fault codes displayed by the control panel.

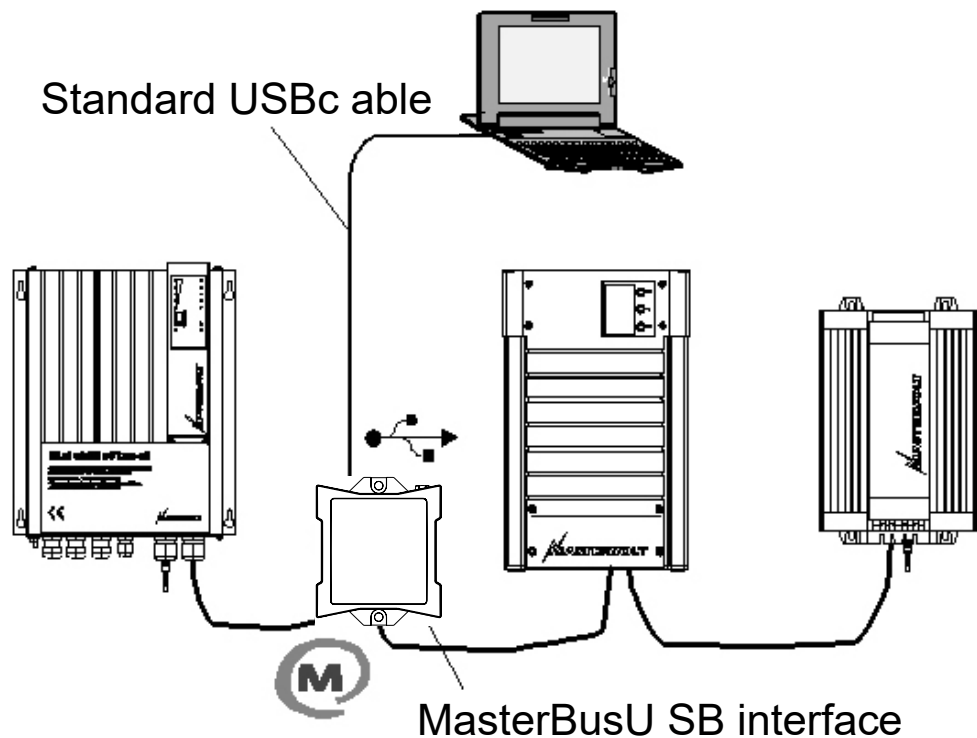

Typical MasterBus communications network showing a PC connected via a MasterBus USB Interface module.

Long-term Storage of the Re(Li)able® 400 Ah Battery Systems

WARNING

Read and follow all manufacturer's safety precautions and operational instructions for the lithium-ion battery power system; including the battery pack, system control panel, and the inverter/charger.

Ensure all users are fully familiar with the battery power system's operation and safety instructions.

Severe injury, fire, or system damage could occur.

WARNING

NEVER SIMULTANEOUSLY CHARGE A BATTERY FROM SHORE POWER AND THE ENGINE ALTERNATOR:

Excessive charging energy will result in battery damage.

WARNING

DO NOT OPERATE THE VEHICLE'S ENGINE IN AN ENCLOSED SPACE.

- If you are in a parked motorhome with the vehicle's engine running, there is a potential for exhaust fumes entering the motorhome.
- Avoid inhaling exhaust gases as they contain carbon monoxide, which is a toxic gas that is colorless and odorless.

NOTICE

Due to the inherent inconsistency of energy supplied from a solar system (weather and other variables), it is not recommended to depend on solar charging alone to provide a maintenance level of battery charging over extended periods of storage.

One advantage of lithium-ion over conventional lead-acid type batteries is that deep discharge over storage periods does not adversely affect battery life. The rate of self-discharge is less than 5% per month, depending on the storage environment. High or low ambient temperatures affect the rate of self-discharge and natural aging. If possible, the battery(ies) should be stored in a dry and well-ventilated environment. Ideal ambient temperature range for storage is 23° F to 95° F (-5° C to 35° C).

The objective of long-term storage is to isolate the batteries from AC and DC devices that can introduce parasitic loads, which over a short time can drain the battery(ies).

If the battery(ies) will not be used for a period exceeding 3 months AND Shore Power is available:

1. When an external AC power source is available (shore power), adapt the 30-amp shore power connector to a 15/20 amp 3-prong household plug. Adapters are available through RV parts and accessories suppliers.
2. On the Mastervolt SmartRemote, set the AC-IN limit to 15 amps or less. Doing so will limit the power load that the charger will draw from the shore power source, preventing an overload that might trip the shore power circuit breaker.
3. At the Power Load Center, turn OFF the Main AC circuit breaker. This will disable the air-conditioner and other AC power loads, eliminating possible AC loading of the battery(ies).
4. Connect the shore power cord to a 15/20 amp AC source (household receptacle).
5. Turn OFF the rotary master battery switch. This will disable all 12-volt circuits (lights, water pump, fans, etc).

*NOTE: The **charger** section of the CombiMaster inverter/charger is always active when shore power is present. The rotary master battery switch also acts as a remote ON/OFF switch for the CombiMaster inverter section. To maintain remote inverter switching, the MAIN (power) switch, located on the bottom of the CombiMaster, must remain in the OFF (O) position.*

If your system has a SmartRemote, the inverter can be remotely turned off by pressing P1 (see illustration).

Once the batteries receive a full charge, the inverter/charger will provide a float voltage (13.5 V) to the battery(ies); maintaining a proper low-energy charging voltage throughout the storage period.

If a shore power source is NOT available:

1. Before storage, charge the battery(ies) to 80% of capacity by starting the engine and charge the batteries with the charging alternator. At engine idle, the alternator will provide charging energy, but charging time will be reduced by driving the vehicle (providing higher engine RPMs). When parked, avoid over-revving the engine. Monitor the state of charge (SOC) with the Victron battery display.
2. Park and turn the engine OFF when the battery(ies) reach 80% SOC (100% is recommended).
3. Turn OFF the rotary master battery switch.

The battery(ies) can be kept for several months without maintenance. However, it is highly recommended to charge the battery(ies) to 80% of its capacity every 3 months (90-100 days).

Recharging the batteries:

1. Turn ON the rotary master battery switch.
2. If the vehicle is stored in an enclosed area, start the engine and move to an open area. Charge the battery(ies) via the charging alternator.
3. Monitor the SOC with the Victron battery monitor.
4. When charging is complete, turn OFF the engine and turn OFF the rotary master battery switch.

NOTE: If the battery(ies) have discharged too far, they may enter a 'shut-down' or 'sleep' mode. If the batteries do not seem to be accepting a charge, press and hold the Emergency Start Switch for several seconds. Doing so provides voltage to the charging alternator's voltage regulator so that the alternator will begin to provide charging energy to the batteries.

Another method of 'waking up' batteries that have discharged too far is to connect to shore power. This will turn-on the CombiMaster battery charger, providing charging energy in the correct charging profile for the batteries.

Additional System information:

- The rotary master battery switch should be turned OFF whenever the motorhome is not being used.
- The battery(ies) shut down (enter 'sleep' mode) when their voltage drops below approximately 10 volts, or their SOC drops to between 0% and 10%. To re-awake, a charging source must be provided.
- Re-charge the battery(ies) by connecting to a shore power source or by operating the vehicle's engine, charging via the charging alternator. Remember, to start charging a discharged battery (less than 10% SOC), the Emergency Start Switch may need to be pressed for several seconds (while the engine is running). The Emergency Start Switch may also need to be momentarily pressed (10-15 seconds) when charging depleted batteries via shore power.
- When charging from shore power, always set the AC-IN limit equal to or less than the shore power circuit breaker rating.
- For efficient cold weather operation, the battery(ies) has internal heaters. Internal heaters only turn ON when a charging source is present.

- Batteries should NOT be charged if the ambient temperature is above 113° F (45° C). The alternator regulator turns OFF vehicle charging at this temperature. Charging by shore power or solar power is not automatically limited by temperature. Users should prevent charging by these methods when ambient temperatures are extremely high.

When the storage period ends and the lithium-ion battery system is placed back into service:

- Remove the 15 amp, 3 prong standard household adapter from the shore power cord.
- Re-set the AC-IN to match the standard 30-amp shore power input.

Operating the Mastervolt SmartRemote monitor:

- Pressing P1 (first button on left) turns the inverter ON/OFF
- Pressing P2 or P3 reveals sub menus, where adjustments to power sharing, AC IN, and other parameters are made



Mastervolt SmartRemote Inverter Monitor and Remote Controller

Victron Energy, model BMV-712-Smart battery monitor.



Long-term Storage of the Re(Li)able® 460 Ah Battery System

WARNING

Read and follow all manufacturer's safety precautions and operational instructions for the lithium-ion battery power system; including the battery pack, system control panel, inverter/charger, and auto-start module.

Ensure all users are fully familiar with the battery power system's operation and safety instructions.

Severe injury, fire, or system damage could occur.

WARNING

NEVER SIMULTANEOUSLY CHARGE A BATTERY FROM SHORE POWER AND THE ENGINE ALTERNATOR:

Excessive charging energy will result in battery damage.

WARNING

DO NOT OPERATE THE VEHICLE'S ENGINE IN AN ENCLOSED SPACE.

- If you are in a parked motorhome with the vehicle's engine running, there is a potential for exhaust fumes entering the motorhome.
- Avoid inhaling exhaust gases as they contain carbon monoxide, which is a toxic gas that is colorless and odorless.

NOTICE

Due to the inherent inconsistency of energy supplied from a solar system (weather and other variables), it is not recommended to depend on solar charging alone to provide a maintenance level of battery charging over extended periods of storage.

One advantage of lithium-ion over conventional lead-acid type batteries is that deep discharge over storage periods does not adversely affect battery life. The rate of self-discharge is less than 5% per month, depending on the storage environment. High or low ambient temperatures affect the rate of self-discharge and natural aging. If possible, the battery(ies) should be stored in a dry and well-ventilated environment. Ideal ambient temperature range for storage is 23° F to 95° F (-5° C to 35° C).

The objective of long-term storage is to isolate the batteries from AC and DC devices that can introduce parasitic loads, which over a short time can drain the battery(ies).

If the battery(ies) will not be used for a period exceeding 3 months AND Shore Power is available:

1. When an external AC power source is available (shore power), adapt the 30-amp shore power connector to a 15/20 amp 3-prong plug. Adapters are available through RV parts and accessories suppliers.
2. On the Mastervolt System Control Panel (EasyView 5), locate the menu for AC-IN and set the AC-IN limit to 15 amps or less. Doing so will limit the power load that the charger will draw from the shore power source, preventing an overload that might trip the shore power circuit breaker.
3. At the Power Load Center, turn OFF the Main AC circuit breaker. This will disable the air-conditioner and other AC power loads, eliminating possible AC loading of the battery(ies).
4. Connect the shore power cord to a 15/20 amp AC source.
5. Turn OFF the master battery switch. This will disable all 12-volt circuits (lights, water pump, fans, etc).

*NOTE: The **charger** section of the CombiMaster inverter/charger is always active when shore power is present. The rotary master battery switch also acts as a remote ON/OFF switch for the CombiMaster's inverter section. To maintain remote inverter switching, the MAIN (power) switch, located on the bottom of the CombiMaster, must remain in the OFF (O) position.*

The inverter section may also be switched ON/OFF by the EasyView 5 Controller. Locate the INVERTER menu and follow the screen prompts.

Once the batteries receive a full charge, the inverter/charger will provide a float voltage (13.5 V) to the battery(ies); maintaining a proper low-energy charging voltage throughout the storage period.

If a shore power source is NOT available:

1. Before storage, charge the battery(ies) to 80% of capacity by starting the engine and charge the battery(ies) with the charging alternator. At engine idle, the alternator will provide charging energy, but charging time will be reduced by driving the vehicle (providing higher engine RPMs). When parked, avoid over-revving the engine. Monitor the state of charge (SOC) with the EasyView 5 Control Panel.
2. Park and turn OFF the engine when the batteries reach 80% SOC (100% is recommended).

3. Set the Safety Relay(s) knob to the LOCK OFF position. Doing so disables all external loads from the battery pack(s).
4. Turn OFF the rotary master battery switch.

The battery(ies) can be kept several months without maintenance. However, it is highly recommended to charge the battery(ies) to 80% to 100% of capacity every 3 months (90-100 days).

Recharging the Batteries:

1. Turn ON the master battery switch.
2. Turn ON the safety relay(s) by rotating the knob clockwise and depressing the center.
3. If the vehicle is stored in an enclosed area, start the engine and move to an open area. Charge the battery(ies) via the charging alternator.
4. Monitor the state of charge (SOC) via the Mastervolt EasyView 5 Control Panel.
5. After charging is complete, turn OFF the safety relay(s) and the rotary master battery switch.

NOTE: If the battery(ies) have discharged too far, they may enter a 'shut-down' or 'sleep' mode. If the batteries do not seem to be accepting a charge, connect to shore power and the CombiMaster battery charger should 'awake' and start charging the battery(ies).

If this method does not seem to start the charging process, a Mastervolt technician may be able to remote-in to the battery system and get the battery operational (see page 118).

Additional System information:

- The rotary master battery switch should be turned OFF whenever the van is not being used.
- The battery(ies) shut down (enter 'sleep' mode) when their voltage drops below approximately 10 volts, or their SOC drops to between 0% and 10%. To re-awake, a charging source must be provided. It is possible that a very-low discharged battery will require a Mastervolt technician's service to 're-awake' a battery pack.
- Re-charge the battery(ies) by connecting to a shore power source or by operating the vehicle's engine, charging via the charging alternator. Remember, to start charging a discharged battery (less than 10% SOC), the Emergency Start Switch (if installed) may need to be pressed for several seconds (while the engine is running). The Emergency Start Switch may also need to be momentarily pressed (10-15 seconds) when charging depleted batteries via shore power.

- When charging from shore power, always set the AC-IN limit equal to or less than the shore power circuit breaker rating.
- For efficient cold weather operation, there are external heat pads installed for the battery(ies). These heating pads only turn ON when: (1) the safety relay(s) are ON; (2) the rotary battery switch is ON; (3) and the ambient temperature is near or below 32° F (0° C).
- Batteries should NOT be charged if the ambient temperature is above 113° F (45° C). The alternator regulator turns OFF vehicle charging at this temperature. Charging by shore power or solar power is not automatically limited by temperature. Users should prevent charging by these methods when ambient temperatures are extremely high.

When the storage period ends and the lithium-ion battery system is placed back into service:

- Remove the 15 amp, 3 prong standard household adapter from the shore power cord.
- Re-set the AC-IN to match the standard 30-amp shore power input.
- Turn the safety relay(s) to their ON position (rotate the knob clockwise and depress the center).

NOTE: Refer to the manufacturer's instructions regarding system configuration, operation, and fault codes displayed by the control panel.



Safety Relay in the OFF position. 400 and 460 Ah systems have one safety relay, while 800 and 920 Ah systems have two safety relays, one for each battery pack.

Illustration of Mastervolt's EasyView 5 control panel in the battery monitor mode



120-volt Power System

Power for the 120-volt AC electrical devices installed in your motorhome is supplied by:

- The on-board generator, or;
- Shore power, or;
- The inverter.

The standard inverter is not designed to power the entire 120-volt system and when used, care must be exercised so that overloading the inverter is avoided. However, the inverter supplied with the optional Re(Li)able Battery Power System is capable of powering all 120-volt appliances.

Shore Power

DANGER

CONNECTING THE SHORE CORD TO A NON-GROUNDED OR IMPROPERLY GROUNDED POWER SOURCE CAN RESULT IN DANGEROUS AND POSSIBLY FATAL ELECTRIC SHOCK.

Due to the potential danger in failing to heed this warning, the motorhome manufacturer cannot be responsible should damage, injury, or death result from failure to connect the power cord to a properly grounded power source.

WARNING

The campsite 120-volt power receptacle(s) should always be tested for proper functionality prior to connecting your motorhome's shoreline power cord to it. Do not hook up the shoreline power cord to any receptacle until you have verified proper polarity and grounding.

DO NOT plug the shoreline power cord into a campsite receptacle:

- That has reverse polarity
- With non-functioning ground circuits
- That shows outward signs of heat or other damage

Doing so may result in property damage or severe injury. Damage or injury resulting from a connection to a malfunctioning or improperly wired power source is not covered by warranty.

It is the responsibility of the owner of the electrical service stand to ensure that the receptacles are properly wired and grounded. Reverse polarity and/or improper grounding of your motorhome can cause equipment damage, personal injury, or death.

WARNING

THIS CONNECTION IS FOR 110-125 VOLT AC, 60 HZ, 30-ampERE SUPPLY. DO NOT EXCEED CIRCUIT RATING. EXCEEDING THE CIRCUIT RATING MAY CAUSE A FIRE AND RESULT IN DEATH OR SEVERE INJURY.

Make sure the circuit breakers at the electrical power source are in the OFF position before connecting or disconnecting your shoreline power cord.

WARNING

- The shoreline power cord must be fully extended when in use, and not left coiled in the electrical compartment or on the ground.
- Do not use cheater plugs, adapters, or extension cords to reconfigure incoming alternating current (AC) power or break the continuity of the circuit connected to the grounding pin.
- Do not connect the shoreline power cord into an outlet that is not grounded or adapt the power cord plug to connect it to a receptacle for which it is not designed.
- Do not remove the grounding pin to connect to a non-grounded receptacle. Removal of the ground pin disables an important safety feature designed to prevent shock and electrocution hazards.
- Do not lengthen the shoreline power cord with an extension cord. Use of an improper extension cord will cause overheating of the cord as well as potentially causing premature failure of on-board electrical equipment.
- Damaged shore power cords are an electrical shock hazard. Inspect cords for damaged or missing contact pins, cut or damaged insulation, and frayed wires. Replace damaged shore power cords immediately.

CAUTION

- It is strongly advisable to test the wiring of any external power source **BEFORE** connecting your motorhome. Along with a proper ground, the 120-volt AC source must have properly wired neutral and hot terminals.
- Testing for correct power source wiring can be easily accomplished with a portable polarity tester, obtained from a RV parts supplier or dealer. Follow the instructions provided by the manufacturer when operating the tester.
- If a problem with the external power source is found, **CONTACT THE CAMPSITE MANAGER** for repairs. Do not attempt repairs to the site power source and do not connect your motorhome to the site power source until it is determined safe to do so.

Typical Camp-ground electrical service stand. This illustration shows 50-amp, 30-amp, and 15-20 amp outlets, along with corresponding circuit breakers.



⚠ WARNING

THIS CONNECTION IS FOR 110-125-VOLT AC, 60 HZ, 30 AMPERE SUPPLY. DO NOT EXCEED CIRCUIT RATING. EXCEEDING THE CIRCUIT RATING MAY CAUSE A FIRE AND RESULT IN DEATH OR SERIOUS INJURY.

A Warning Label, similar to the one shown here, is affixed on your motorhome, near the 30-amp shoreline cord inlet.

30-amp, 120-volt Shoreline Power Cord

⚠ WARNING

MOTORHOMES THAT ARE FACTORY-EQUIPPED WITH A 30-AMP ELECTRICAL SERVICE SHOULD NEVER BE CONNECTED TO A POWER SOURCE THAT WILL PROVIDE MORE THAN 120-VOLTS AC.

Although the 3-prong, 30-amp RV connectors look similar to 240-volt AC connectors found in residential homes (electrical dryers, stoves, etc.), the 30-amp RV power service is designed for 120-volts AC only.

Failure to follow this power requirement will result in serious damage to appliances and electrical devices.

Your Class B motorhome is designed for 30-amp electrical service, a 30-amp shoreline power cord is provided to attach the motorhome to a grounded 110-125 volt AC, 30-amp external power source.

IMPORTANT! NEVER CONNECT YOUR 30-AMP SHORE POWER CORD TO AN ELECTRICAL SOURCE THAT SUPPLIES MORE THAN 120-VOLTS AC.

Always turn OFF the main power switch or circuit breaker of the shore power electrical outlet before connecting or disconnecting the shoreline power cord. This will eliminate arcing of electrical contacts and reduce the potential of electrical shock. Please strictly follow all electrical-related safety labels affixed to your motorhome.

NOTE: Connect the pronged (or male) end to the shore power cord to the external electrical service, and the socket (or female) end to the motorhome's electrical connection port.

Connecting to an External Power Source

Inquire with the campsite owner or manager if they provide the electrical service your motorhome requires. It is always advisable to ensure the external electrical source is properly wired and grounded before connecting your motorhome. If the external electrical source is confirmed to be appropriate for your motorhome's electrical system, follow this electrical hook-up procedure:

1. Locate the load center inside your motorhome and turn OFF the main AC circuit breakers. Some panels will have two main circuit breakers.
2. Carefully extend the entire length of the shoreline power cord (approximately 35 feet) from the electric cable port on the motorhome to the external power source.
3. Ensure the circuit breaker(s) at the external power source are OFF.
4. Connect the shore power cord to the receptacle on the motorhome. If the connector has a locking ring, carefully engage the threads until snug. Some connector designs may require a slight twist after insertion.
5. Plug the shoreline power cord into the 30-amp external power receptacle, matching the power requirements and power cord connector of your motorhome. Be sure all the connector prongs are properly and completely inserted into the power source receptacle.
6. Turn ON the circuit breaker at the external power source.
7. Turn ON the main circuit breaker(s) at the motorhome's load center.



Typical shoreline power cord connection port

NOTE: Always turn **OFF** the air-conditioner, furnace, and all electrical appliances before connecting and disconnecting the shore power cord from the 120-volt AC power source and/or before operating or turning off the generator.

When you are ready to leave the campsite, reverse the shoreline power cord connection process. Use care to prevent damaging the electrical connection pins when connecting or disconnecting the shoreline power cord. Grasp the plug to remove the shoreline power cord from the outlet; do not unplug it by pulling on the cord.

Shore Power Wiring Configuration

For safe electrical power for your motorhome's electrical system, it is important that the external power source is correctly wired. If the shore power source is incorrectly wired, it is possible that the chassis frame and metal objects could become energized. It is also extremely important that the shore power source is properly grounded, thus protecting from the physical hazards of electrical shock.

Below are illustrations of the proper wiring for the 50-amp and 30-amp shore power cords and their corresponding power receptacles. Please talk to the campground's maintenance personnel if you have any questions or concerns regarding the wiring of the campground's electrical hook-ups.

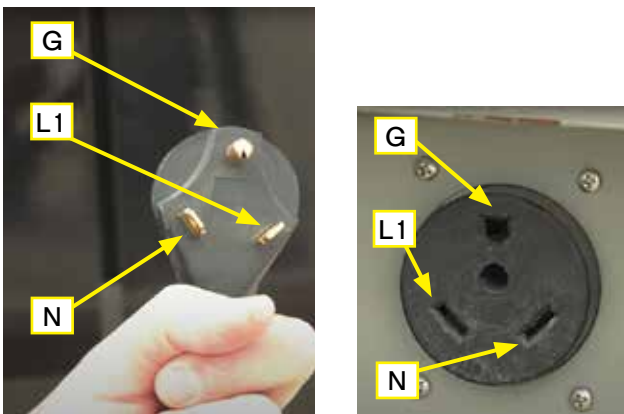

G = Ground L1 = Leg 1 (120 VAC measured to neutral or ground)
N = Neutral

Standard 3-prong, 120-volt, 30-amp RV shore power plug and receptacle wiring configuration

Shoreline Cord Plug Adapters

⚠ WARNING

USE EXTREME CAUTION WHENEVER ADAPTING SHORE POWER CORDS TO AN UN-MATCHED (CURRENT) ELECTRICAL SERVICE.

For example: 30-ampere shore power cord to a 15-20 ampere service.

The significantly reduced amount of available incoming power could damage electrical motors, compressors, and other devices.

⚠ WARNING

NEVER ADAPT A 30-AMP SHORE POWER CORD TO A 50-AMP EXTERNAL POWER SERVICE.

SEVERE ELECTRICAL OVERLOAD TO THE SHORE POWER CORD AND/OR THE MOTORHOME'S ELECTRICAL SYSTEM COMPONENTS COULD CAUSE ELECTRICAL FIRES OR OTHER DAMAGE.

⚠ CAUTION

REDUCE POWER LOADS WHENEVER ADAPTING A LARGER AMPERAGE SHORE POWER CORD TO A SMALLER SHORE POWER SOURCE.

DO NOT USE POWER-CONSUMING ITEMS, SUCH AS AIR-CONDITIONERS, MICROWAVE OVENS, ETC.

Using a 120-volt, 15-20 amp power adapter:

Power cord adapters are available in several styles and configurations. Only use adapters when absolutely necessary and on a temporary basis. Be aware that the use of adapters restricts power to the motorhome's electrical system.

Only use 120-volt, 15-10 amp adapters on a limited basis, such as powering a few internal lights, powering a refrigerator to cool it before travel, or providing charging energy for your auxiliary batteries when the motorhome is in storage. Do not use high-demand electrical devices, such as air-conditioners



30-amp to 15-20 Amp Shore power cord adapter

and microwave ovens. Electrical overloads can easily happen and could cause damage to the electrical devices of your motorhome.

Trickle Charging Batteries During Storage

The shore power cord and the motorhome's converter can be used to keep the auxiliary batteries charged during storage.

1. Use a plug adapter to convert the shore power plug to a standard, 3-prong household outlet.
2. At the motorhome's circuit breaker panel, turn ON the Main Circuit breaker(s) and the Converter circuit breaker. Turn OFF all other circuit breakers.
3. Plug in the shore power cord to the household outlet.
4. Turn ON the master battery switch.
5. Ensure all interior lights and 12-volt devices are OFF or disconnected from the power source.

Incoming Power Protection

Beginning with model year 2022, TMC motorhomes are equipped with transfer switches that provide reverse polarity and open ground protection. If there is a fault with the shore power source or generator power, a fault warning message will be displayed on the multiplex main panel screen and power will not be passed through the transfer switch to the motorhome (see Transfer Switch section).

If a ground or reverse polarity fault is detected, the shore power source or generator must be repaired by a qualified technician or electrician.

Shore Power Cord Maintenance

Inspect the shoreline power cord for damaged or missing contact pins, cuts, cracks, and worn insulation. Damaged shore power cords are an electrical shock hazard. For your own safety and to maintain the integrity of the electrical system, replace damaged shore power cords immediately.

Power and Electrical Accessories

Your dealer is the best source for advice and recommendations for shore power accessories, such as power plug adapters, extensions, circuit testers, surge protectors and other useful devices pertaining to shore power and the electrical system of your motorhome.

Always respect electrical energy and never use an electrical device that is faulty or damaged. Only use an electrical device or accessory for its designed purpose.

Generator (if equipped)

DANGER

OPERATING THE GENERATOR CREATES EXHAUST GASES THAT CONTAIN CARBON MONOXIDE. CARBON MONOXIDE IS POISONOUS AND CAN CAUSE UNCONSCIOUSNESS AND DEATH.

- **THE GENERATOR PRODUCES DANGEROUS FUMES WHEN IT IS RUNNING. SEVERE PERSONAL INJURY, DEATH, AND EQUIPMENT DAMAGE CAN RESULT FROM OPERATING THE GENERATOR IN A GARAGE, BUILDING, OR A CONFINED SPACE. WHENEVER THE MOTORHOME IS PARKED OR STORED IN A GARAGE OR CONFINED SPACE, DISABLE THE AGS SYSTEM TO PREVENT THE GENERATOR FROM AUTOMATICALLY OPERATING.**
- **TO AVOID EXHAUST GAS ENTRY INTO THE MOTORHOME, KEEP WINDOWS CLOSED WHEN THE CHASSIS OR GENERATOR ENGINES ARE RUNNING.**
- **Test the CO/LP detector installed in your motorhome frequently to ensure protection from carbon monoxide and/or LP gas leaks. If an alarm sounds, immediately shut off the generator and all gas and electric appliances and evacuate the motorhome. Turn off the main battery disconnect switch and main gas valve at the LP tank. Seek medical assistance if necessary. Have all necessary repairs to equipment made by a qualified technician before continuing use.**
- **Disable the AGS system when sleeping in the motorhome. The potential of carbon monoxide poisoning is present when the generator is operating and the CO/LP alarm may not awake you to the hazard.**
- **When parked, be sure that the generator's exhaust is clear of any obstructions, such as underbrush, rocks, and snow. Follow all generator safety guidelines provided by TMC in your owner's manual and the instruction manual provided by the generator's manufacturer.**

CAUTION

Read and understand the generator owner's manual before operating the generator. Observe all operating instructions and warnings, as well as all recommended maintenance schedules and procedures.

NOTICE

Your motorhome's generator may be equipped with features that prevent operation if certain maintenance parameters are not met, i.e., low engine oil level, clogged air and fuel filters, etc.

NOTICE

If your generator fails to start or shuts off unexpectedly, and there is an adequate fuel supply and 12-volts DC present, it may need maintenance attention. Refer to the manufacturer's owner's manual for troubleshooting and maintenance procedures.

IMPORTANT: READ AND UNDERSTAND THE GENERATOR OWNER'S MANUAL BEFORE OPERATING THE GENERATOR. Observe all operating instructions and warnings as well as all recommended maintenance schedules and procedures.

The on-board generator allows your motorhome to be electrically self-contained. It provides 120-volts AC when shore power is not available (via the automatic transfer switch) and indirectly provides 12-volt DC energy through the converter.

Generator operating controls are integrated into the main multiplex panel. Review and follow all operational and safety precautions provided by the generator's manufacturer, written on warning labels and provided in the manufacturer's owner's manual, which is included in your Owner's Packet.

1. **DO NOT** operate the generator while sleeping or allow others to sleep in the motorhome while the generator is operating. You would not be aware of exhaust gases entering the motorhome or be alert to symptoms of carbon monoxide poisoning.
2. **DO NOT** operate the generator in an enclosed building or in a partly enclosed area such as a garage or storage unit.
3. **DO NOT** operate the generator when the motorhome is parked in high grass or brush. Heat from the exhaust could ignite dry vegetation.
4. **DO NOT** operate the generator longer than necessary when the vehicle is parked. This will help to reduce exhaust gases near the motorhome.
5. **DO NOT** simultaneously operate generator and a ventilator fan, which could result in the entry of exhaust gas. When ventilator fans are used, open a window on the opposite side of the motorhome and 'upwind' of generator's exhaust pipe, to provide cross ventilation.
6. **DO NOT** open nearby windows, ventilators, or doors into the passenger compartment, particularly those which can be 'down wind,' even or short periods of time. When parked, orient the vehicle so that the prevailing winds will carry the exhaust away from the motorhome.
7. **DO NOT** operate the generator when parked in close proximity to vegetation, snow, buildings, vehicles, or any other object could deflect the exhaust under or into the vehicle.
8. **DO NOT** touch the generator when running, or immediately after shutting OFF. Heat from the generator can cause burns. Allow the generator to cool before attempting maintenance or service.
9. **DO NOT** use the generator if the exhaust system is damaged. Before using the generator, inspect the exhaust system. Test the carbon monoxide alarm every time you use the motorhome. If the CO alarm sounds, immediately move everyone to fresh air and ventilate the motorhome. Shut the generator OFF, and do not operate it until it has been inspected and repaired by a qualified technician.

Operating tips:

- The main battery switch must be ON to start and operate the generator.
- Control switches for operating the generator are incorporated in the multiplex touchscreen panel.
- Always turn OFF the air-conditioner, furnace, and all electrical appliances before disconnecting the shoreline power cord from the 120-volts AC power source and/or before shutting OFF the generator.
- The generator operates on gasoline drawn from the vehicle's fuel tank. In some installations, fuel will not reach the generator if the level of the vehicle's fuel tank drops to a certain level (usually 1/4 tank).

NOTE: Generators supplied with diesel-powered Class B motorhomes are fueled by propane gas. When operating the generator, observe all propane-related safety precautions.

Starting and Stopping Procedures

Your generator can be started and stopped from the main multiplex control panel, integral control panel on the generator, or from the multiplex system's remote phone app. Outlined here are the simple steps for starting and stopping the generator:

- Before starting the generator, turn OFF air-conditioners and large electrical loads.
- Before starting in cold weather, turn OFF all appliances for best long-term performance.

To start:

1. Locate the Generator ON/OFF switch, on the Monitor Panel or integrated into the Multiplex Control Panel.
2. Prime the engine by holding the OFF position of the start/stop switch for a few seconds. The LED on the switch will turn on.

3. After priming, press and hold the ON position until you hear the generator start. The LED will flash during starting, then remain on when the generator is running.
 - a. The engine will turn over and should start within a few seconds.
 - b. If the engine fails to start within a few seconds, do not over-crank.
4. Before turning ON appliances, let the generator warm up for a few minutes. Generally, a beep from an appliance indicates that the generator is supplying electricity.
5. Under normal operating conditions, you may detect the engine of the generator increase and decrease in RPM (run faster and slower). This is normal, due to changes in electrical power demand.

To stop:

1. Turn off air-conditioners and large electrical loads and allow the generator to run for 3-5 minutes before stopping, to allow the generator to cool down.
2. Press and hold the switch in the OFF position until the generator stops. The indicator LED on the switch will turn off.

NOTES:

- *To prevent generator overload due to initial start-up current demand, turn ON air-conditioners and appliances in a sequential order and only after the generator is started and runs for a few minutes.*
- *If you lose power to the motorhome while operating the generator, check the overload circuit breaker on the generator; it may have tripped due to too much power demand. Turn off some appliances or electrical devices in order to reduce the total power demand.*
- *If your generator fails to start or remain running, and there is an adequate fuel supply and 12-volts DC present, it may need maintenance attention. Refer to the manufacturer's owner's manual for troubleshooting and maintenance procedures.*
- *Turn off all appliances before resetting a tripped circuit breaker. If the breaker trips again with all electrical loads off, turn off the generator and contact a qualified technician for repairs.*
- *If your motorhome is supplied with an AGS system, refer to your motorhome's Owner's Packet for details regarding its features and operation.*

- *If your motorhome has a multiplex wiring system, settings for the automatic generator start system are incorporated in the Settings Menu of the multiplex system.*
- *For complete generator instructions, refer to the manufacturer's guidelines included in your Owner's Packet, or available through your TMC Owners Resource account, or available from the manufacturer's website.*

Automatic Generator Start (if equipped)

DANGER

Disable the AGS system when sleeping in the motorhome or when the motorhome is parked in a garage or confined space. The potential of carbon monoxide poisoning is present when the generator is operating.

WARNING

Fully disable the Automatic Generator Start (AGS) system before performing service and maintenance procedures on the generator.

Failure to do so may result in death or severe injury.

Your motorhome may be equipped with an Automatic Generator Start (AGS) system. An AGS can be a stand-alone system, part of the generator's control circuitry, or part of the inverter's control system. The purpose of an AGS system is to automatically start (and run) the generator when certain programmed parameters are encountered:

- When the auxiliary battery(ies) voltage drops to a predetermined level, the AGS circuitry will sense the low voltage condition and start the generator, which, in turn, supplies charging voltage to the batteries through the inverter/charger. Once the system batteries have regained a sufficient amount of charge, the AGS will automatically turn off the generator.
- When there is a power demand from air-conditioners, some models may feature a thermostat interface, where if the temperature of the coach rises to a programmed level, the generator will start, allowing the air-conditioner to operate. The AGS will automatically turn off the generator after the air-conditioner turns off.
- Some units are time-programmable, enabling the user to determine when the generator will operate. This feature is useful if the campground has restrictions regarding running generators during certain time periods of the night.

- Motorhomes equipped with a 12-volt DC compressor-type refrigerator are typically outfitted with a stand-alone AGS. When turned ON, the AGS will automatically start the generator when the auxiliary battery(ies) drop to a programmed voltage level, therefore, keeping the refrigerator operational.

When the auxiliary battery(ies) have reached a state of full-charge, the AGS will automatically turn OFF the generator.

Refer to the manufacturer's instructions for complete AGS operating and safety information. Copies are included in your Owners Packet or on-line through the TMC Owners Resource Information Service.

Generator Access

CAUTION

Due to the mounting position of the generator, ground clearance of the motorhome is restricted. Always be mindful of road hazards, curbs, speed bumps, and other road-related issues that could impact and damage the generator.

If damaged, do not operate the generator until all repairs are properly performed.

The generator is located underneath the vehicle, secured by mounting brackets. The vehicle must be raised to access the generator for service or maintenance. Always secure a raised vehicle with jack stands.

Refer to the vehicle manufacturer's owner's manual for proper jacking procedures.

Automatic Transfer Switch (if equipped)

WARNING

The transfer switch provides protection from reverse polarity and ground faults due to faulty shore power source and generator wiring.

DO NOT DEFEAT THESE PROTECTIVE FEATURES. SEVERE DAMAGE TO THE ELECTRICAL SYSTEM, INCLUDING ELECTRICAL SHOCK COULD OCCUR.

All TMC Class B motorhomes are equipped with a transfer switch rated for 30-amp service. Do not attempt to connect to a higher amperage power source.

The Automatic Transfer Switch is an electronically controlled relay that senses the presence of 120-volts AC incoming power; either from shore power or from the on-board generator. It automatically switches between these two incoming power sources, connecting the active incoming power source to

the Power Load Center, thereby powering the motorhome's electrical system.

When 120-volts AC is not present, the Automatic Transfer Switch connects the auxiliary battery to the coach 12-volt system. If an inverter is installed, limited 120-volts AC is available for a restricted number of circuits and appliances.

The Automatic Transfer Switch operates under these conditions:

- When shore power is sensed, it connects the external AC power source to the Power Load Center.
- If there is a shore power outage and the generator is started, either manually or by the Automatic Generator Start System (AGS), incoming power is switched from the shore power source to the generator after a 20-45 second delay.
- If shore power returns while the generator power is present, the system remains on generated power until the generator is turned off. With the generator off, electrical power for the motorhome is switched to the shore power source.
- The generator overrides shore power.
- If 120-volts AC is not present, check the circuit breakers at the shore power source and/or the output of the generator.

Incoming power protection:

TMC motorhomes are equipped with transfer switches that provide reverse polarity and open ground protection. If there is a fault with the shore power source, a fault warning message will be displayed on the multiplex main panel screen. Power will not be passed through the transfer switch to the motorhome until the fault is corrected.

If a fault message is displayed:

1. Contact the park maintenance personnel to check the wiring of the shore power source. **DO NOT ATTEMPT TO REPAIR A FAULTY SHORE POWER SOURCE. LEAVE IT TO A PROFESSIONAL ELECTRICIAN.**
2. If 120-volts AC is NOT present while attempting to power your motorhome with the on-board generator, check the circuit breakers on the generator.
 - › Turn OFF air-conditioner and other electrical appliances.
 - › Reset circuit breakers if needed.
 - › Re-start the generator and after 30 seconds, turn ON electrical appliances. If power is not restored, have a qualified service technician look into possible problems with the generator or transfer switch.

Power Load Center: 30-amp

⚠ DANGER

- **Do not force a tripped circuit breaker into resetting. A tripped circuit breaker indicates a problem with the circuit that must be corrected.**
- **Never bypass or defeat circuit breakers or circuit fuses.**
- **Do not replace circuit breakers with one of a higher current rating.**
- **Do not replace blown fuses with a fuse of a higher current rating.**

Circuit damage could result, creating the potential of electrical shock, electrocution, and fire.

⚠ WARNING

A qualified RV electrician should perform any repairs to the electrical system of your motorhome. If misused, electrical energy is dangerous and can cause fires, electrical shock, or electrocution.

The All-in-One Power Load Center of your motorhome provides electrical control for both 120-volt AC and 12-volt DC circuits. This unit consists of three main components:

- 120-volt AC Circuit Breaker Panel
- 12-volt DC Fuse Panel
- Converter



Power Load Center

The Power Load Center is usually located in the rear bed pedestal or a rear closet, but may be located elsewhere within the motorhome. Each circuit of the main power panel is labeled according to the device(s) connected to it.

120-volt Circuit Breaker Panel

⚠ WARNING

Replacement circuit breakers must be of the same voltage, amperage rating, and type. Never use a higher rated replacement circuit breaker than what was originally installed with your motorhome. Doing so may cause a fire by overheating the motorhome's wiring.

The 120-volt AC section of the Power Load Center contains toggle-type circuit breakers. Circuit breakers protect the 120-volt wiring and components in your motorhome from circuit overloads and shorted circuits. Should a circuit overload or short circuit occur, the circuit breaker protecting the affected circuit will 'trip,' preventing the flow of electricity to that circuit.

A circuit breaker identification label is permanently attached to the inside surface of the 120-volt AC Load Center. The circuit breakers will **NOT** offer complete protection of the motorhome electrical system in the event of a power surge or spike.

If a circuit breaker trips, turn OFF and unplug the electrical appliance(s) or devices on that circuit and allow the circuit breaker to cool down. After the cool down period, reset the circuit breaker by moving the switch to the OFF position and then back to the ON position, then plug-in the electrical devices and try operating them. If the circuit breaker re-trips or frequently trips, unplug the appliances(s) on the circuit and contact your selling dealer's service department to have the electrical problem diagnosed and repaired. It is possible that the appliance is faulty, not the circuit.

If the circuit breaker refuses to re-set, this indicates there is something wrong with that circuit. **DO NOT ATTEMPT TO FORCE THE CIRCUIT BREAKER TO THE ON POSITION:**

- The circuit may be overloaded with too many devices.
- The device may draw more current than what the circuit is designed to supply.
- The device may have developed an internal short circuit.
- The circuit wiring or outlet (receptacle) may be damaged.

IMPORTANT! DO NOT attempt to use that circuit or device until the problem is determined and repaired by a qualified electrician.

Maintenance

Before using your motorhome, inspect the circuit breakers and replace them as needed. Test each circuit breaker by moving the individual switches to the OFF position, and then back to the ON position. Circuit breakers may degrade over time and, as part of your motorhome's maintenance, must be replaced as needed.

NOTES:

- Circuit breakers and fuses are vital in keeping the electrical system of your motorhome in a safe operational condition. Never bypass or defeat circuit breakers or circuit fuses.
- Some electrical appliances may have their own circuit breakers. If there is an interruption in electrical service of an appliance, consult the manual for that appliance to determine the recommended action to take.
- For motorhomes equipped with a multiplex wiring system, the power load center and associated circuit breaker/fuse panels is quite different than the power load center described in this section.
- For information regarding multiplex wiring systems, please contact your selling dealer or a TMC Customer Care representative.

12-volt Fuse Panel**⚠ WARNING**

Replacement fuses must be of the same voltage, amperage rating, and type. Never use a higher rated replacement fuse as it may cause a fire by overheating your motorhome's wiring.

The circuits that receive power from the 12-volt DC section of the Power Load Center are protected by automotive blade-type (ATC) fuses. The 12-volts DC fuse panel label indicates fuse sizes, positions, and the electrical components powered by the 12-volt circuits. To determine if a fuse has BLOWN (unable to pass electricity), it must be pulled from its socket and visually inspected. A blown fuse will have a distinct, open gap in the wire or conductor between the fuse blades.



ATC Blade-Style Fuse

Only replace blown fuses with fuses of the same size and current rating of the fuse that was originally supplied in the fuse socket. Each socket is labeled with the correct current rating. Replacing any fuse with a higher current rated fuse will create an unsafe condition, possibly causing circuit damage and a fire.

A blown fuse indicates a problem with the circuit that is associated with the fuse. You must determine the cause and take corrective actions whenever a fuse is blown. Possible causes of blown fuses are:

- Too many devices attached to the circuit, causing circuit overload.
- The circuit may be overloaded by a device that demands more energy than what the circuit is designed to deliver.
- A short-circuited or defective device attached to the circuit.
- A short-circuited wire or outlet associated with the circuit.

Before replacing a fuse always shut OFF the engine, generator, and all motorhome electrical systems completely. Make sure the electrical components listed on the fuse label are in the OFF position:

1. Shut OFF the chassis engine.
2. Disconnect the shoreline power cord.
3. Shut the generator OFF (if equipped).
4. Turn the inverter OFF (if equipped).
5. Turn OFF the master battery switch.
6. Remove the fuse panel cover.
7. Turn OFF the electrical device identified on the fuse label.
8. Pull the fuse straight out of the fuse block. If inspection of the fuse confirms that it is not blown, some other electrical problem may exist.
9. Insert a new fuse of the same specified voltage, amperage rating, and type in the original location. Never use a higher rated replacement fuse. Additionally, lower-rated fuses will likely blow, for they will not allow adequate current to the device(s) on that circuit.

The fuse panel label should be kept permanently affixed to your motorhome. The fuses will not offer complete protection of the motorhome electrical system in the event of a power surge or spike. Fuses are maintenance components and must be replaced as needed. Please contact your selling dealer's service department for further repair assistance.

Take corrective action to repair any defective electrical circuit or device. If help is needed, seek assistance or repairs from a qualified RV electrician or technician.

NOTE: Blade-type fuses come in several sizes; mini, standard and large. The fuse sockets of the Power Load Center only accept standard ATC-size blade type fuses.

Keep a supply of properly rated blade-type fuses on hand in case a fuse needs to be replaced. Replacement fuses can be obtained at auto parts stores or auto repair facilities.

Converter (if equipped)

NOTICE

If the converter is not operating correctly, the reverse polarity protection fuse may be blown (located on the converter front panel). Check the connections on the auxiliary battery for proper polarity and correct if necessary. If a fuse requires replacement, only replace with one of the same type and rating.

The power converter is a 12-volt power supply, which provides 12-volts DC from incoming 120-volts AC, either supplied from an external shore power source or the on-board generator. The converter also provides charging energy for the auxiliary battery(ies). The converter is typically housed within the power load center of 30-ampere electrical systems, but it can be a stand-alone unit in some applications.

The converter has a built-in protective thermal breaker that will shut it down should overheating occur. Overheating can be caused by operating the converter above its maximum power output for an extended period of time, or by an obstruction to its ventilation air flow.

Converter operation modes:

Most converters are automatic three-stage switching power supplies. The converter senses which mode it needs to be in by sensing the demands of the motorhome's power demand.

- **Absorption mode/Normal operation:** During this mode, the converter output is in the 13.6 volts, DC range. This is the normal operation mode. This mode provides the 12-volts DC and current required by the 12-volt lighting, appliances, and devices; well as slow charging the auxiliary battery(ies).
- **Bulk mode/Charge mode:** In this mode, the output voltage of the converter will switch to 14.4 volts DC range for a maximum of four hours. This mode provides extra energy for faster auxiliary battery charging. If the converter cycles between 'Absorption and Bulk mode', there could be a shorted battery cell or other issues.

- **Float mode/Trickle charge:** In this mode, the converter is charging the battery with a trickle voltage of 13.2 volts DC. When the converter senses a demand (by turning on lights or other 12-volt devices), the converter automatically returns to the 'Absorption mode.'

NOTE: The master battery switch must be ON for charging energy from the converter to connect to the auxiliary batteries.

Using the converter:

Under normal operating conditions, the converter requires no user attention or maintenance. However, if the auxiliary battery(ies) happens to become reverse connected, fuses that protect the converter from cross-polarization may blow. If your converter is not operating, check the polarity of the auxiliary battery connections and correct if necessary. If the fuses on the front panel of the converter have blown, replace with the same type and amperage rating. If the incoming AC voltages are normal, but the converter output is still not delivering 12-volts DC, the converter requires repair. Contact the manufacturer for service details.

Due to the high level of electrical energy it supplies, the converter may be warm to the touch when operational, and this is normal. It does, however, have built-in thermal protection; if it gets too hot, it will turn itself off. After it cools down, the converter will return to normal operation. In most cases, this thermal cycling is caused by some object being placed in too close of proximity to the converter, preventing it from receiving adequate ventilation. Make sure not to place anything near the converter that could obstruct ventilation.

Inspection and maintenance:

If the power converter is not working, check the fuse(s) located on the outer case. There are no consumer serviceable parts inside the converter case and the manufacturer's warranty will be voided if the case has been opened. If you have further concerns, please contact your selling dealer.



Typical converter: model, features, and installation location varies, depending on motorhome model and floor plan.

GFCI Receptacle

⚠ WARNING

If the GFCI receptacle fails EITHER the self-test or manual test, turn OFF power to the failed circuit at the Power Load Center. Do not restore power to the faulty circuit until proper repairs have been made.

Your motorhome is furnished with ground fault circuit interruption (GFCI) protection on specific 120-volt AC receptacles (outlets). GFCI receptacles are found in the bath, while receptacles in the kitchen area and exterior may be electrically connected to this circuit; therefore, also GFCI protected.

The GFCI outlet does not protect against short circuits or electrical overloads. Circuit breakers in the Power Load Center, which supply power to the circuit, will trip if these conditions exist.



Typical GFCI receptacle

GFCI receptacles are compliant to the self-test industry standards implemented in 2015. These new GFCI's automatically monitor the presence of ground, and if a ground fault is present, whether a load is plugged in or not, the GFCI shuts off power to the receptacle. Although the self-testing feature increases the safety of the receptacle, it does not eliminate the need for occasional manual testing of the GFCI circuit breaker to ensure it is working properly. Manually test GFCIs at the beginning of the travel season and monthly thereafter.

To test the GFCI circuit breaker:

1. Make sure power is switched ON to the circuit. Use a test meter, test probe or a low-wattage electrical device.
2. PUSH the test button. The RESET button should pop out.
3. With the RESET button out, all power should be interrupted (OFF) to the receptacle being tested.
4. Verify there is no voltage to the receptacle by using the test probe or low-wattage electrical device.
5. Push the RESET button IN to restore power to the GFCI.
6. Verify that voltage has been restored to the GFCI receptacle.

If the reset button does not pop out after pushing the test button, or GFCI circuit breaker continues to trip, or if the power is not interrupted to the test light, immediately turn OFF power at the main circuit breaker panel and have a qualified electrician repair the circuit or replace the GFCI. Do not use that circuit until repairs are made.

If a non-GFCI receptacle is 'dead', check the near-by GFCI circuit breaker; it may need to be reset. If so, unplug all electrical devices from the GFCI receptacle and all receptacles wired to this circuit, and reset it. Then, monitor it for proper circuit functionality.

If resetting the GFCI does not restore power to it and to the other GFCI-protected receptacles **and** the corresponding circuit breaker in the Power Load Center is **not** tripped, then there is a problem with the electrical circuit or GFCI receptacle. Enlist the service of a qualified electrical technician for repairs. Do not use that circuit until repairs are made.

NOTE: It is normal RV wiring practice to wire one or more electrical receptacles to the GFCI circuit. If another outlet in the motorhome is 'dead' check the GFCI in the bathroom; it may be tripped.

Outside 120-volt AC Receptacle

⚠ WARNING

NEVER USE AN APPLIANCE OR ELECTRICAL DEVICE THAT IS NOT PROPERLY GROUNDED OR HAS A MISSING OR DEFEATED GROUND PIN. INJURY OR DEATH DUE TO ELECTROCUTION IS POSSIBLE.

Your motorhome is equipped with a convenient outside 120-volt AC power receptacle (outlet) that is useful for operating appliances and entertainment devices. For your safety, the outside receptacle is electrically grounded and ground-fault protected (Ground Fault Circuit Interruption, or GFCI).

Powering the outside receptacle:

The outside 120-volt AC power receptacle is energized whenever the motorhome is connected to shore power or the on-board generator is running. In typical RV wiring fashion, this receptacle is wired to a circuit that is ground-fault protected and likely includes other receptacles; usually located in the bathroom and kitchen; areas where the likely-hood of water is present. Refer to your motorhome's 120-volt wiring diagram to locate other receptacles on the GFCI circuit.

This page is intentionally blank

Propane Gas Safety

DANGER

IF YOU SMELL PROPANE GAS

1. Extinguish any open flames and all smoking materials.
2. Shut off the propane supply at the container valve(s) or propane supply connection.
3. Do not touch electrical switches.
4. Open doors and other ventilating openings.
5. Leave the area until the odor clears.
6. Have the propane system checked and leakage source corrected before using again.

Ignition of flammable vapors could lead to a fire or explosion and result in death or severe injury.

DANGER

All pilot lights, appliances, and their igniters (see operating instructions) shall be turned off before refueling of motor fuel tanks and/or propane containers.

Can cause ignition of flammable vapors, which can lead to a fire or explosion and result in death or severe injury.

DANGER

NEVER TRAVEL WITH, AND/OR STORE PROPANE (LP) CONTAINERS OR CYLINDERS INSIDE YOUR MOTORHOME.

Propane cylinders are designed to vent whenever internal pressures reach a certain threshold. Therefore, the potential of a venting propane cylinder presents a gas leak hazard, which, if ignited, could lead to an **EXPLOSION, FIRE, AND SERIOUS BODILY INJURY OR DEATH.**

WARNING

ALL PROPANE GAS IS CONTAINED UNDER PRESSURE. DUE TO THE DANGEROUS POTENTIAL OF ANY COMPRESSED GAS, IT IS MANDATORY THAT THE FOLLOWING REQUIREMENTS FOR THE USE OF THIS TANK BE FOLLOWED:

Tanks are to be installed, fueled, and maintained in accordance with the state and local codes, rules, regulations, or laws and in accordance with the NFPA Pamphlet 58, division IV.

WARNING

ROAD VIBRATION CAN LOOSEN PROPANE FITTINGS. It is important to check the Propane System for leaks at least every 5,000 miles, and whenever the tank is filled. It is also recommended to have the entire Propane System checked annually by a qualified propane service technician.

WARNING

THIS PROPANE PIPING SYSTEM IS DESIGNED FOR USE WITH PROPANE ONLY.

- Do not connect natural gas to this system.
- Securely cap inlet when not connected for use.
- After turning on propane, except after normal cylinder replacement, test propane piping and connections to appliances for leakage with soapy water or bubble solution.
- Do not use products that contain ammonia or chlorine to test for leaks. These substances may weaken piping components and cause gas leaks, leading to fire or explosion, which could result in death or severe injury.

CAUTION

Several main propane system components are installed underneath the vehicle. Due to their location, these components may be subjected to damage caused by road hazards or other travel-related circumstances.

CAUTION

Regularly inspect the propane system for possible damage and do not use the propane system until all damage is properly repaired.

NOTICE

Class B Motorhomes powered by a diesel engine may not include a propane (LP) system. The furnace and water heater use diesel fuel to generate heat, while the kitchen is equipped with an induction cooktop. Other appliances are powered by electricity; either 12-volts DC or 120-volts AC.

Introduction

Propane or liquefied petroleum (LP) gas is a clean and efficient source of energy that provides fuel for cooking, heating, hot water, and generating electricity (by a propane-fueled generator, if equipped). Propane is also used as an energy source for refrigeration (evaporative-type RV refrigerators).

Propane is a colorless and odorless gas that, when under pressure, is in a liquefied state. An odorant (usually a sulfur compound) is added as a detection agent. If you smell propane within or around your motorhome or hear the propane alarm (CO/LP alarm), quickly and carefully perform the procedures listed on the safety alerts at the beginning of this section, listed in Section 3, Vehicle Safety, and safety labels affixed to your motorhome.

Strictly adhere to all propane safety warnings and operational guidelines printed on propane appliances, devices, and included in propane appliance manufacturer's operational manuals.

Always be mindful that propane gas can be hazardous if used improperly. Propane is heavier than air, and if leaking, the gas tends to flow and accumulate in low areas, such as the floor. Ensure the combination CO/LP detector is properly maintained and operational. Observe and follow proper handling and safety precautions when using propane gas and propane appliances.

The propane system installed in your motorhome is comprised of numerous components such as the propane tank, main gas valve (solenoid-actuated), gas hoses, propane gas regulator, gas piping, gas appliances, and copper (or steel) tubing lines and valves within each gas appliance.

As part of your normal maintenance routine (at least once a year), have a qualified propane service technician perform an inspection of your entire propane system, including a system pressure test (appliances, tank, regulator, hoses, piping, and fittings).

Traveling With Propane

DANGER

Turn OFF all pilot lights, appliances, and their igniters (see operating instructions) while the motorhome is traveling or in motion, and before refueling the motorhome's fuel tanks and/or propane containers.

Can cause ignition of flammable vapors, which can lead to a fire or explosion and result in death or severe injury.

As with all on-board fuel (diesel, gasoline, or other), traveling with propane does present a level of risk, yet risks can be minimized by following a few basic travel precautions.

- Some states prohibit propane appliances to be operated during travel, especially in underground tunnels, across bridges, or on a ferry. While traveling, you may also encounter local restrictions against transporting flammable materials (other than the fuel for the motorhome's engine). Make sure you are familiar with the transportation laws for the areas where you will be traveling, by checking beforehand with the state's or province's Department of Transportation (DOT) or similar regulatory office.
- Never travel or stow auxiliary propane gas cylinders inside the motorhome or inside a non-vented storage compartment. All ASME (American Society of Mechanical Engineers) certified propane gas tanks and cylinders have a safety pressure relief system that is designed to vent propane gas to the atmosphere if a certain internal pressure threshold is reached. A hazardous condition exists if gas venting is contained within the motorhome or an enclosed storage compartment.
- Over time, road vibrations can cause gas fittings and connections to loosen. Make it part of your routine motorhome inspection to check all gas fittings, valves, and connections, for looseness and possible gas leaks.
- Keep your CO/LP detector in good working order and test it at the beginning of your travel season and least once a week while traveling.
- Be sure your traveling companions know what to do if propane gas is detected, either by smell or by the sounding of the CO/LP alarm. **TAKE IMMEDIATE SAFETY ACTIONS WHENEVER GAS IS DETECTED.** Review and practice evacuation procedures.
- Operating a gas appliance(s) while traveling presents the risk of fire and/or explosion if the vehicle encounters some type of road hazard or vehicle damage. To reduce risk, always travel with gas appliances OFF and the propane system main valve OFF.
- **EXTINGUISH ALL PILOT LIGHTS AND OPEN FLAMES, AND TURN OFF APPLIANCES WITH ELECTRONIC IGNITERS BEFORE ENTERING A FUELING STATION AND DURING FUELING FOR EITHER VEHICLE FUEL OR PROPANE GAS.**

Propane Tank

DANGER

Always shut OFF the motorhome's engine while refueling propane tank. Do not smoke. Turn off all appliances with automatic igniters and do not operate other ignition sources while refueling.

Over-filling the propane gas tank can result in uncontrolled gas flow which can cause fire or explosion. A properly filled tank will contain approximately 80% of its volume as liquid propane.

An 80% automatic shut-off valve is installed on the propane gas tank which will automatically prevent further filling when the gas volume has reached 80% of tank capacity.

WARNING

Do not fill propane container(s) to more than 80 percent of capacity. A properly filled container contains approximately 80 percent of its volume as liquid propane.

Overfilling the propane container(s) can result in uncontrolled propane flow, which could lead to a fire or explosion and result in death or severe injury.

If you suspect your propane container has been overfilled, immediately contact your selling dealer or a qualified propane technician for assistance. Do not attempt to service or correct a propane container overfill yourself.

CAUTION

Propane tanks are to be installed, fueled, and maintained in accordance to country, federal, state, and local codes, rules, regulations, laws, or guidelines

Never use another LP tank other than the one furnished with the motorhome. If the LP tank must be replaced, check with your dealer for correct LP tank specifications and replacement procedures.

NOTICE

New propane containers are filled with an inert gas, which must be carefully purged before filling with propane. The propane tank must NEVER BE OVERFILLED with propane (more than 80% by volume)

Hand tighten propane gas system valves; do not use a wrench or pliers as over tightening may damage the valve seals and cause them to leak.

A permanently mounted ASME approved propane container (tank) is mounted under the floor of your motorhome. A fill port with a main LP gas shut-off switch is located on the LP access panel, positioned along the lower left side of the vehicle. Propane expands 1½ percent for every ten degrees Fahrenheit (5.5° C) of increase in temperature. When filling, it is imperative to leave sufficient space inside the container to allow for natural expansion of gas during warmer weather.

Monitoring Propane Levels

The amount of propane contained in the propane tank can be monitored by pressing the appropriate monitor buttons on the motorhome's main multiplex system panel. Refer to Electrical System Section.

Filling and Servicing the Propane Tank

Given that the propane tank is not removable, the motorhome will need to be driven to a qualified propane facility for filling and servicing. Only an authorized propane service technician(s) should be near the motorhome while the propane tank is being filled. Drivers and passengers should wait at a safe distance away from the motorhome until LP filling and servicing is complete.

IMPORTANT: NEVER OVERFILL THE PROPANE TANK!

Never allow your propane tank to be filled above the maximum safe level as indicated by the fixed liquid level gauge (if equipped). Overfilling the propane container above the liquid capacity indicated on the gauge could allow liquid propane to enter the system that is designed for vapor only, creating a hazardous condition.

NOTES:

- The capacity or size of a propane tank is expressed in pounds (lbs.) and correlates to the weight of the propane it is capable of containing when filled to 80% capacity, not the total volume capacity of the tank.
- For example: If your motorhome has a 40 pound capacity LP Tank, filling it to 80% = 32 pounds of LP. LP weighs 4.2 lbs./gallon, so the 80% capacity of a 40 pound LP tank is 7.6 gallons (32÷4.2).

Using the Propane System

⚠ DANGER

Do not use gas cooking appliances for comfort heating. Can lead to carbon monoxide poisoning, which can lead to death or severe injury.

⚠ WARNING

Gas cooking appliances need fresh air for safe operation. Before operating:

- Open vents or windows slightly or turn on exhaust fan prior to using cooking appliance.
- Gas flames consume oxygen, which should be replaced to ensure proper combustion.
- Improper use can result in death or severe injury.

⚠ WARNING

RANGE COVERS MUST BE OPEN WHEN THE SURFACE BURNERS ARE IN OPERATION.

IF YOUR MOTORHOME HAS A PRIVACY CURTAIN WITHIN 6 FEET OF THE GAS COOKTOP; do not operate unless the privacy curtain is secured away from the appliance or removed.

Do not store combustible materials on or near gas appliances.

May cause a fire, which could result in death or severe injury.

NOTICE

Some appliances, such as furnaces, water heaters and refrigerators, are equipped with automatic propane igniters, while some stove or oven models may require lighting a pilot light before operating the appliance.

MAKE SURE THAT YOU READ AND FULLY UNDERSTAND ALL SAFETY REQUIREMENTS FOR HANDLING AND OPERATION OF ALL GAS APPLIANCES AND DEVICES OF THE PROPANE SYSTEM.

To operate the main gas valve solenoid, 12-volt DC power must be present by turning ON the master battery switch. When 12-volt DC power from the auxiliary battery is OFF or unavailable, the gas valve is in-operable and remains CLOSED. However, if battery power is restored and the main propane gas valve switch was left in the ON position, the main gas valve solenoid will OPEN.

Main Gas Valve

The main propane gas valve installed on this vehicle is controlled by an electrical solenoid. The actuation switch for the gas valve is located on the propane access panel, positioned along the lower left side of the vehicle. This panel also contains the propane tank fill port and a propane tank bleeder valve.



Propane access panel, positioned along the lower left side of the vehicle

Turning ON the propane gas:

1. Ensure the master battery switch is ON.
2. Ensure ALL burner valves, controls, and pilot light valves are closed.
3. Turn ON the main gas valve switch. When the red light on the switch illuminates, it indicates that the main gas valve is OPEN.
4. Listen carefully as propane begins to flow. If a hissing noise is heard for more than one or two seconds, **THERE MAY BE A GAS LEAK!** Turn OFF the main gas valve switch and contact your selling dealer's service department to have the propane system tested.
5. Operate the gas appliance(s) and devices as needed, following the appliance manufacturer's instructions.

Turning OFF the propane gas:

1. CLOSE and turn OFF all burner valves, controls, and pilot lights to all gas appliances and devices.
2. Turn OFF the main gas valve switch. The red light on the switch will extinguish, indicating the gas valve is CLOSED.

NOTES:

- The main propane valve installed on this vehicle is controlled by a rocker switch, controlling a gas-valve solenoid. It has a built-in red light that when illuminated, indicates the main gas valve is **OPEN**. To close the gas-valve, turn **OFF** the gas valve switch (red light extinguishes).
- The main propane valve solenoid is only powered by the auxiliary battery (12-volts DC). It is **NOT** powered through shore power or the generator (via the converter). The Main Battery Disconnect switch must be **ON** in order to use of the propane system.

Furnace/Water Heater Gas Shut-off Valve

Several TMC Class B motorhome models are equipped with a Truma furnace/water heater combo (see Interior Section). The main heating unit is equipped with a gas shut-off valve, which is electrically controlled by a switch that is located on the main unit. The switch (Fig. 1) shuts off the power to the safety gas shut-off valve and therefore, the gas supply to the Combi furnace. Under normal operations, this switch can be left **ON** because operating the furnace and water heating control is done on a separate control panel.

Use this gas valve shut-off whenever maintenance to the unit is required, or when storing the vehicle for an extended period. To make sure that the gas supply to the furnace is off, turn the switch to the **OFF** position. If the furnace/water heater is not producing hot water or hot air, check the position of this switch; it must be in the **ON** position for the unit to operate properly.

NOTE: This switch does not affect gas supply to other gas appliances within the motorhome, nor does it affect the main gas valve switch of the motorhome.

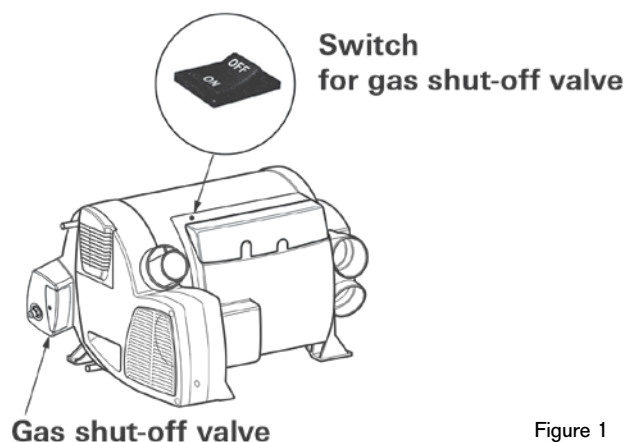

Figure 1

External Propane Hook-up**⚠ DANGER**

Only operate external LP gas appliances for their intended purpose. Follow all safety and operational instructions associated with the appliance. The risk of fire, explosion or severe bodily injury exists.

Propane available at this source is at normal and regulated operating pressure. Never bypass or defeat the gas regulator installed on the motorhome's propane system.

⚠ WARNING**WHEN USING THE OUTDOOR COOKING AREA:**

- The vehicle must be level and stabilized.
- Do not violate manufacturers' instructions on required clearances for cooking appliances during use.
- Do not store cooking appliances until cool to the touch.

Can lead to a fire and explosion and result in death or severe injury.

⚠ WARNING

The Auxiliary Propane Gas Hook-up is equipped with a manual LP gas shut-off valve, located near the quick-disconnect coupler.

- Always turn **OFF** this gas valve when this LP source is not in use.
- Ensure this shut-off valve is closed whenever connecting and disconnecting gas appliances to the external propane hook-up.
- As with the main gas valve, ensure this valve is in the **OFF** position when traveling.

⚠ CAUTION

Ensure that children and pets stay well away from any gas appliance in use or connected to the external propane hook-up.

Do not use or operate appliances designed for outdoor use inside the motorhome.

Potential injuries due to trips, falls, flame and heat exist whenever an external gas hose, along with a gas appliance is in use.

NOTICE

Some gas appliances may have built-in gas regulators that could make the device incompatible with this low-pressure propane source.

Your motorhome may be equipped with an external propane quick connect/quick disconnect. This low-pressure gas source is a convenient propane connection for an external gas appliance, such as a gas grill, fryer, or other gas device.

This external propane gas hook-up is equipped with a quick-disconnect coupler and a manually actuated shut-off valve. Always connect the gas appliance or device to the coupler before opening the shut-off valve. Turn the valve **OFF** before disconnecting the gas appliance or device.

ALWAYS CLOSE THE GAS SHUT-OFF VALVE WHEN THIS EXTERNAL LP HOOK-UP IS NOT IN USE.

The external propane gas hook-up is plumbed after the propane system's gas regulator, so the gas pressure at this gas port is low; on or about 11 inches water column (approximately 0.5 PSI). Refer to the manufacturer's instructions of the external gas appliance or device to determine the required operating gas pressure.

The gas device may also need to be fitted with the mating end of the quick-disconnect coupler. The device's manufacturer or your RV retailer should be able to provide hook-up coupler recommendations.

Safe Use of This LP Port:

Please follow all propane gas safety warnings associated with this propane connection and all external gas appliances. When using external gas devices, be extremely cautious of fire and explosion hazards that may be present. Only use devices that are designed for use outdoors and at the regulated gas pressures of the motorhome's propane system.

Be sure all flammable materials remain a safe distance away from the LP appliance when it is in use and during cool-down; including awnings and other fabrics that may be attached to or near the exterior of the motorhome. Keep the LP appliance or device on firm, level ground and at a safe distance from the motorhome to prevent heat-related damage or fire to the motorhome. Be sure all gas supply hoses are out of pedestrian or pet traffic paths. Be sure to warn children and keep them away from flames and hot surfaces.

- **ALWAYS TURN THE MAIN LP GAS VALVE OFF WHENEVER TRAVELING AND RE-FUELING; BOTH THE MOTORHOME'S ENGINE FUEL AND WHEN RE-FILLING THE LP TANK.**
- **NEVER BYPASS OR MODIFY THE FACTORY SET PRESSURE OF THE PROPANE REGULATOR OF THE MOTORHOME'S PROPANE SYSTEM.**
- **ALWAYS KEEP THE MANUAL SHUT-OFF GAS VALVE LOCATED ON THE EXTERNAL PROPANE HOOK-UP OFF WHEN THE PORT IS NOT IN USE.**



(Above) Typical external propane hook-up port. (Right) manual gas shut-off valve.

- **ALWAYS FOLLOW THE GAS APPLIANCE MANUFACTURER'S INSTRUCTIONS FOR SAFE OPERATION OF ALL GAS DEVICES.**
- **ALWAYS ENSURE THE QUICK DISCONNECT COUPLER SEATS PROPERLY INTO THE CONTAINMENT COLLAR BEFORE TURNING ON THE GAS VALVE. IMMEDIATELY STOP USING THIS LP CONNECTION IF LEAKING LP GAS IS DETECTED. DO NOT USE UNTIL PROPER REPAIRS HAVE BEEN MADE.**
- **DO NOT** use an external gas appliance if weather conditions would present a risk of tip-over, flare-ups, or other unsafe operating conditions.
- **DO NOT** use an external grill or griddle underneath an extended awning or rain fly. Rising heat from the device could severely damage awning fabric, cause a fire, or cause severe injury.
- **DO NOT** use an external grill or griddle in close proximity to the motorhome or camper van. Heat from the device could cause severe damage to painted surfaces, graphics, or plastic components.
- **NEVER** leave an operating LP gas appliance unattended, not even for a short period of time. You must be able to immediately extinguish the device and turn off the gas supply if an unintended situation should arise.
- **TURN OFF** the propane gas supply to the appliance when the appliance is not in use. This external propane

hook-up has its own manual gas shut-off valve, located directly behind the quick disconnect port.

- ENSURE the external gas appliance is completely cool to the touch before stowing it away. The storage bins of your motorhome could be damaged or worse, a fire could ignite if a hot appliance is placed in the storage bins.
- NEVER operate or use an appliance that is designed for out-of-doors use inside the motorhome; either as a heat source, for food preparation, or for any other purpose. The risk of SUFFOCATION, FIRE, EXPLOSION, SEVERE INJURY AND DEATH exists.
- ROUTINELY INSPECT all external gas appliances, devices, gas supply hoses, and connections for leaks, cracks, or other damage. DO NOT USE the gas appliance if it needs repairs. Only use the gas appliance after proper repairs have been made.

To Operate the External Propane Hook-up:

1. Ensure the manual shut-off valve is OFF.
2. Confirm your gas appliance is fitted with a proper gas hose and mating connector, and if so, connect it to the propane quick-release port.
3. Turn ON the main gas valve.
4. Slowly open the manual shut-off valve, listening to ensure there are no gas leaks. **IF A GAS LEAK IS DETECTED, IMMEDIATELY CLOSE THE SHUT-OFF VALVE. DETERMINE AND REPAIR THE SOURCE OF THE LEAK.**



Although designed for a wide variety of outdoor LP uses, the External LP Hook-up port provides a particularly convenient LP connection source for gas grills and griddles.

5. When safe to do so, operate the gas appliance.
6. After using the gas appliance, turn **OFF** the manual shut-off valve and disconnect the appliance from the port.
7. Allow the appliance to completely cool before stowing it away.

NOTE: This propane port provides LP gas at about 0.5 PSI or 11 inches water column. Some gas appliances may have built-in gas regulators that could make the device incompatible with this low-pressure propane source. Always follow the appliance manufacturer's recommendations when modifying or removing LP gas regulators.

Propane Leak Test

WARNING

If a propane gas leak is detected, close all gas valves and turn off all igniters.

Do not use any part or component of the propane system until the leak is properly repaired by a qualified technician.

Propane leaks may be found easily with a soapy water solution. Do not use a solution containing ammonia or chlorine. These chemicals are corrosive to copper gas lines and brass fittings, which could result in deterioration of the copper and brass components.

Apply the soapy solution to the outside of the gas pipe fittings. If a leak is present, the soapy solution will 'bubble' at the leak point. If a leak is indicated, shut OFF the propane system valve(s) at the propane tank, and immediately contact your selling dealer's service department or qualified propane service representative to arrange repairs.

This page is intentionally blank

Section 11: Water System

Freshwater System

Potable (drinking) water is supplied throughout your motorhome from either the freshwater holding tank or from a connection to an outside water source. When using the freshwater holding tank, water is pressurized and travels through the water lines by means of the water pump. When utilizing an external water source, such as a campsite water spigot, the water pump is not needed (it is bypassed by check valves), as the campsite water source provides pressurized water to the motorhome.

Potable Water Hose

To supply safe potable water to your motorhome, purchase and keep separate a sanitized water hose, whose sole function is for use with your potable water delivery and storage. Use a different water hose for other water-related activities, such as cleaning outdoor furniture, washing the motorhome, maintenance, or sewer system cleanup.

Filters may be purchased and installed in-line with the hose to provide filtered water to the motorhome.

City Water Connection

CAUTION

External water sources can develop high water pressure, particularly in mountainous regions. These campgrounds or hook-up locations may not have regulated water pressure, which could be considered excessive.

High water pressure is anything over 55 psi. Excessive pressure may cause leaks or damage to your motorhome's water system.

NOTICE

When connected to an external water source, it is strongly recommended that a water pressure regulator is used in-line with the water supply delivery hose. Water pressure regulators are designed to reduce high external water supply pressures to a level that is safe for your motorhome's water system, preventing potential damage. RV water pressure regulators can be obtained at RV suppliers or dealers.

When an external freshwater source is available, connecting to it will help conserve the water supply on board, while eliminating the need to use your on-board water pump (water pressure is provided by the external source).

1. Set your water heater bypass valves (if installed) to the correct position listed on your water system label. Do not operate the water heater if its water supply is bypassed.
2. Remove the cap from the freshwater inlet, located on the left side of the motorhome. The city water hook-up is the top port. The lower port is the freshwater tank fill.



City water fill connection, along with a storage chamber for the sewer hose. This image for reference only. The water ports on Class B motorhomes vary in type and location due to floor plans and features.

3. Attach one end of your potable (drinking) water hose to the external water source spigot.
4. Connect the other end of the hose to the motorhome's city water inlet.
5. Turn ON the external water source spigot. Gradually open the hot and cold water at the sinks and tub to clear air from the lines. Close the faucets when the water is flowing freely.

Disconnecting From an External Water Source

1. Turn OFF the external water source spigot valve.
2. Disconnect your potable water hose from the supply spigot and the freshwater inlet of the motorhome.
3. Remove the water hose and store it in an appropriate place.
4. Reinstall the cap on the freshwater inlet.

NOTES:

- If you will be away from your motorhome for a few hours or more, it is a good practice to disconnect or turn off the valve from the city water source. This will prevent or reduce any damage that could be caused by a pressure-induced leak in the motorhome's water system pipes or fittings.
- The use of in-line water filters and pressure regulators (not supplied by TMC) is recommended whenever potable water is being delivered by an external source.

- Ask your dealer for details about these and other useful fresh and wastewater system devices and accessories designed to aid with your water system's operation and maintenance.

Freshwater Holding Tank

WARNING

THE ON-BOARD FRESHWATER HOLDING TANK IS FOR POTABLE WATER ONLY. Sanitize, flush, and drain freshwater tank before using.

Failure to maintain tank may result in death or severe injury.

NOTICE

Do not leave the motorhome unattended while filling the freshwater holding tank. Although the freshwater tank has an overflow vent, incoming water volume may exceed the capacity of the overflow vent, creating excessive pressure within the water tank and possible damage to seals and fittings.

When an outside source of water is unavailable, water can be drawn from the on-board freshwater holding tank.

1. Set your water heater bypass valves (if installed) to the correct position listed on your water system label. **DO NOT OPERATE THE WATER HEATER IF ITS WATER SUPPLY IS BYPASSED.**
2. Remove the cap on the Freshwater holding tank Fill port.
3. Attach a potable water hose to the freshwater holding tank inlet, while attaching the other end of the hose to a source of safe drinking water. Turn ON the valve at the water source. Only use a water hose designated for potable water purposes.
4. When the tank is full and water is coming out of the freshwater overflow tubes located under your motorhome:
 - a. Stop filling the freshwater holding tank;
 - b. Disconnect and stow your water hose;
 - c. Replace the cap on the freshwater holding tank fill port.

To use water from the freshwater holding tank, turn the water pump ON to pressurize the water in the lines and to the water heater. Then, gradually open the hot and cold water faucets to clear air from the lines. Close the faucets when the water is flowing freely.

NOTE: When traveling, it is a good practice only to carry a quantity of freshwater that will meet your needs until arriving at your next destination.

This will reduce the total weight carried by motorhome, allowing for carrying capacity for other items.

Gravity Fill Port

Located on the outside of your motorhome is a gravity fill port for the freshwater holding tank. This feature is used when there is not a potable water hose or safe pressurized water source available for filling the freshwater holding tank.

1. The gravity fresh fill port for the freshwater holding tank is usually located on the left side of the motorhome, near the rear (Figure 1).
2. Open the port access door with the supplied key (Figure 2) and remove the cap (Figure 3).
3. Pour Freshwater ONLY into the port. Replace the cap and close the access door.

The style of the gravity fill port may differ from these illustrations.



Figure 1



Figure 2



Figure 3

Freshwater Holding Tank Drain Valve

NOTICE

When draining the entire on-board freshwater system, make sure to open faucets; then open the water heater drain valve, system low point drain valves, and the freshwater holding tank drain valve.

The freshwater holding tank drain valve is a key component used in freshwater system maintenance. This drain valve is located near the freshwater holding tank and is usually identified by a red T-handle, which operates a ball-valve. The valve may be located behind an access panel, a storage drawer, or inside an equipment storage area.

Use this drain valve to lower or empty the volume of water in the freshwater holding tank. Turn the handle 90 degrees to open and close the valve. The tank drain is plumbed through the floor. The freshwater holding tank has vents that facilitate pressure equalization when draining the tank. If water flow from the valve seems slow, check the tank vents for blockages.

Complete diagrams of the freshwater system installed in your TMC motorhome are available through your on-line TMC Owners Resource account. Look for a document with the floor plan designation and the word 'Schematic' in its title.

Water Pump

NOTICE

- **Do not turn the water pump ON if the freshwater holding tank is empty. Doing so could cause damage to the water pump.**
- **Do not turn the water pump ON when using water from an external source. Only operate the water pump if using potable water stored in your freshwater tank.**
- **The water pump should be turned OFF when the motorhome is left unattended for any amount of time. This may help limit potential damage should something fail within the water system.**

The water pump is used to draw freshwater from the freshwater holding tank whenever the motorhome is not connected to city water (e.g., campsite water). To operate the water pump, 12-volts DC power must be available (turn ON the main battery switch).

Once turned ON at the monitor or multiplex or panel, the water pump (also known as an on-demand pump) will self-prime, pressurize the water lines, and provide water to the faucets, shower, and toilet. As long as the water pump switch is ON, and there is water in the freshwater holding

tank, the pump will automatically cycle on and off as water demand requires.

Operating the water pump:

The water pump is designed to operate automatically on an as-needed basis. Using the water pump continuously, such as leaving a faucet open for an excessive time-period or operating the water pump without water in the freshwater holding tank, will shorten its operational life and is not covered by warranty. The water pump has a check valve that prevents water from back-flowing out the city water fill.

IMPORTANT! DO NOT OPERATE THE WATER PUMP IF THE FRESHWATER HOLDING TANK IS EMPTY OR THE MOTORHOME IS CONNECTED TO AN EXTERNAL WATER SOURCE.

1. Make sure there is adequate supply of water in the freshwater holding tank.
2. Be sure the water heater bypass valves are set correctly according to your water system label. **DO NOT OPERATE THE WATER HEATER IF ITS WATER SUPPLY IS BYPASSED.**
3. Open all the faucets (first hot, then cold) including your interior and exterior shower faucets.
4. Turn the pump switch ON and allow the water pump to fill the water lines and hot water heater tank (if installed). After water is flowing in a steady stream from all your faucets, turn the faucets OFF. The water pump should stop operation automatically when all faucets are closed. The pump should now run 'on-demand' when a faucet is opened and stop when the faucet is closed.
5. The water pump switch must be ON to provide water to the toilet.

The switch for the water pump is usually located on the Monitor Panel or Multiplex Main Panel (if equipped). Refer to Electrical System Section. Some installations provide a water pump switch on the bathroom wall or other convenient locations.

For additional information on the care and operation of the water pump, refer to the water pump manufacturer's information.

Water Pump Strainer

If equipped, periodically check the in-line water pump strainer for accumulated debris. The strainer is usually located on the inlet to the water pump. To clean the water pump strainer shut OFF the water pump, unscrew the clear cap, remove the reusable strainer cartridge, clear any debris, rinse with clean water, and reinstall the strainer and cap.

Freshwater Filter

Your motorhome may be equipped with a cartridge-type freshwater filter. Periodically, the filter cartridge will need to be replaced. Also, when sanitizing or winterizing the water system, be sure to follow the guidelines specified for the water filter. Water system diagrams are included as part of the schematic set for your motorhome, available through your TMC Owners Resource account.

Rear Convenience Panel

Located inside the rear door of some floor plans is a convenience panel and storage area. Included on this panel:

- 120-volt AC receptacle
- 12-volt DC receptacle
- Water pump switch
- Convenience light switch
- Quick disconnect water hose with spray nozzle

The storage area provides a convenient place to stow the shore power cord and the coiled water hose, along with ample room for the potable freshwater hose.



Convenience panel

Exterior Spray Port

CAUTION

Exterior spray ports are not intended as a freshwater drinking source.

Select TMC Class B motorhomes are outfitted with an external water spray port. With a quick-connect connection, the freshwater port provides convenient access to a pressurized water jet for light-duty cleaning of camp gear, hiking shoes, and other items. The external shower includes a shower wand and hose designed to facilitate a variety of camp clean-up duties.

Kitchen Sink

The kitchen unit installed in TMC Class B motorhomes include a freshwater kitchen sink. Typically, the kitchen sink drains into the gray water holding tank.

To operate the kitchen sink faucet:

1. Ensure there is a volume of freshwater in the freshwater holding tank.
2. Turn ON the water pump. Pump controls are located on the water menu of the Multiplex touchscreen panel. The water pump will pressurize the water system and supply water to the faucet.

If connected to an external water supply:

- Water pressure is provided by the external water supply; there is no need to operate the on-board water pump.
- Use water conservatively; the gray water storage tank has a limited capacity.

NOTE: Do not place food or other solid waste down the kitchen or bathroom sinks. The gray water tank could easily become clogged.

Bathroom and Bath Fixtures (if equipped)

Your motorhome may be equipped with a compact, but complete bathroom. Depending on floor plan, features include:

- Toilet
- Flip-down Sink
- Shower and shower curtain
- Vanity with mirror
- Privacy door

The on-board water pump must be ON (along with freshwater in the freshwater holding tank), **or** the motorhome must be connected to an external pressurized potable water source in order to use the bathroom fixtures.

Bathroom sink operation

1. Turn ON the water pump or connect your motorhome to an external pressurized potable water source.
2. Flip down the sink bowl and rotate the faucet over the bowl.
3. Turn on the valves and proceed with washing.
4. Return the faucet and bowl to their stowed position.



Rear Bathroom



Some bathroom doors provide a second set of door latches, which allows for extra room when in the shower (as illustrated here).



Unitized bath with cassette toilet

Shower operation

1. Ensure you have an adequate on-board supply of freshwater or are connected to an external potable water source.
2. Turn ON the combination furnace/water heater and set the desired hot water temperature. The water heater is a quick-recovery tank-type. However, it will need approximately 20 minutes to pre-heat the water. Follow the manufacturer's instructions included in your TMC Owner's Packet.
3. Adjust the water temperature to your preference.
4. Turn ON the water pump, if not connected to city water.
5. Turn on the ceiling vent (if installed). Doing so will help reduce moisture within the motorhome.
6. Always use the shower curtain. Doing so will help reduce moisture and water damage to cabinets and other devices.
7. Turn on the water valve and using the shower wand, proceed with washing. Stow the shower wand when finished washing.

Furnace/Water Heater Combo

⚠ WARNING

CARBON-MONOXIDE POISONING HAZARD!

Failure to follow instructions could result in severe personal injury or death due to carbon-monoxide poisoning if combustion gases enter the RV.

Check that all openings in the outside wall around the vent (and air intake) pipe(s) are sealed to prevent combustion gases entering the RV.

Check that furnace vent and air intake are not obstructed in any way.

Never operate the combination furnace/water heater in an enclosed or confined space.

This combination furnace/water heater presents danger of hot surfaces and hot gases. Do not touch the area around the wall cowl and do not lean any objects against the wall cowl (furnace exhaust).

⚠ CAUTION

Never operate the combination furnace/water heater with the bypass valves closed or it not having an adequate supply of pressurized freshwater available for the boiler unit.

Your motorhome may be equipped with a factory-installed LP-fired combination furnace/water heater, designed specifically for recreational vehicles (Refer to the Heating and Air Conditioning Section of this manual).

The furnace/water heater combination unit has an internal tank that holds a volume of 2.6 gallons of water. Models use a combination of LP gas or diesel fuel, along with an electric element to rapidly heat water and provide warm air. The installation includes a wall-mounted controller to control the furnace/water heater functions.

Set the desired hot water temperature on the furnace/water heater controller. The temperature at the hot water faucets will not exceed this setting (see Furnace/Water Heater Controller on page 169).

For complete safety information and operational instructions on the furnace/water heater unit installed in your motorhome, please refer to the water heater manufacturer's guide contained in your Owner's Packet or visit the water heater manufacturer's website. Information is also available from the on-line TMC Owners Resource Information Service.

Water Heater Bypass Valves

WARNING

NEVER OPERATE A WATER HEATER IF ITS WATER SUPPLY SHUT-OFF OR BYPASSED. SEVERE DAMAGE TO THE WATER HEATER WILL RESULT, ALONG WITH A RISK OF FIRE.

NOTICE

Tankless water heater installations may not include bypass valves. Refer to the manufacturer's instructions regarding any cautions they may have pertaining to the introduction of sanitizing and winterizing chemicals to the water heater and its components.

A water heater bypass valve system may be installed inside your motorhome, usually behind the water heater, in a cabinet or maintenance access area. Bypass valves are used for water heater maintenance operations or when the manufacturer of the water heater cautions against introducing sanitizing and winterizing chemicals to the water heater and its components (see Sanitizing and Winterizing sections of this manual).

To bypass the water heater:

1. Close the valves leading to the cold water inlet and hot water outlet of the water heater.
2. Open the valve between the hot and cold water lines.

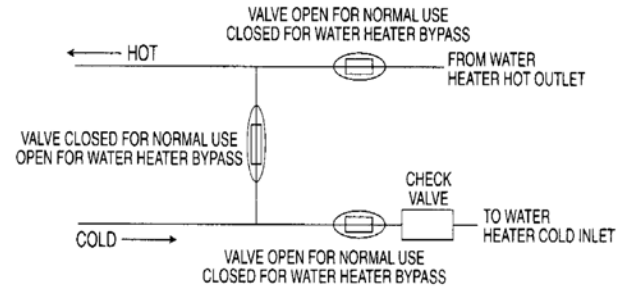

Typical Water Heater Bypass Valve diagram

When the water heater is bypassed for winterizing, be sure to remove the drain plug and drain the water heater's tank. Refer to the manufacturer's instructions for long term storage and winterizing procedures.

When water system sanitizing activities are completed or when putting the water heater back in service, return the bypass valves to their normal positions so that the water heater will have a fresh and replenishing supply of water for normal operations.

Low Point Drain Valves

Low point drain valves are used to drain the freshwater system whenever maintenance, sanitizing, or winterizing is required. The valves are installed in at the lowest point of the water system, thus providing a complete freshwater system evacuation. The valves allow draining the hot and cold water lines. The freshwater holding tank may have a separate drain valve.

For many water system installations, the lowest point of the hot and cold water lines is a water feature, such as an external shower or spray port. Freshwater system diagrams indicate the location of all drain valves.



Low point drain valves are typically located underneath the left-side rocker panel

Low point drains will not evacuate water trapped within the water heater tank. Water heaters typically have separate drains, consisting of a drain plug of some type. Refer to the water heater's manufacturer's instructions for draining procedures.

NOTE: Freshwater system diagrams, which indicate the location of the freshwater holding tank drain valve, low point drain valves, and water heater bypass valves for your motorhome are available through your TMC Owners Resource on-line account.

Holding Tank Heaters (if equipped)

NOTICE

- Operate holding tank heating pads only when the inside temperature of the motorhome is expected to reach 40° F (4° C) or below.
- Operate heating pads only if there is at least a small volume of fluid (a few gallons) in the holding tanks. Damage to the pads or bottom of the storage tanks could occur if fluid is not present.
- Holding tank heaters will not protect other water system components from freeze damage. To protect water lines and other components (if the water system is not winterized), operate the furnace when the inside temperature is expected to be below 40° F (4° C) and set the furnace to maintain at least 40° F (4° C) inside temperature. Open cabinet doors to allow warm air to circulate around plumbing pipes and fixtures.
- Holding tank heating pads operate on 12 volts DC. When operating the heating pads while NOT connected to a shore-power source, always be mindful of the power load that heating pads present to the on-board battery system.
- To prevent freeze damage to the water heater, either operate (turn on) the water heater or ensure the water heater's tank is drained when encountering outside temperatures at or below 32° F (0° C).
- The best method of preventing freeze damage to the water system is to winterize the water system.
- Freeze damage to the water system or any component of the water system is not covered under TMC's limited warranties.

TMC motorhomes may be equipped with holding tank heaters. These devices are heat-pads installed underneath the tanks and are manually activated by a switch, usually located on the main monitor panel or multiplex main menu touch-panel. Activate holding tank heaters whenever encountering sub-freezing temperatures. Other TMC motorhomes may be designed with furnace heat ducting directed to the water storage bays, which is designed to effectively prevent freeze damage to the water storage tanks. Ask your dealer if your motorhome is equipped with supplemental water storage tank freeze protection.

Water System in Cold Weather

⚠ CAUTION

Always be very cautious when using the motorhome's water system in cold weather. Freezing water can severely damage water system components.

Take actions to prevent freezing water damage to pipes, plumbing, and other water system components.

Many owners choose to use their motorhomes throughout the entire year or encounter freezing temperatures during travel. Due to the risk of severe damage, prolonged use of the water system in severely cold weather is not recommended. However, winter traveling can be safe for your motorhome's water system if you follow a few precautions.

- To avoid damage caused by freezing, the water system and storage tanks of your motorhome are dependent on the ambient temperature of the motorhome remaining above 32° F (0° C). When fully functioning and the temperature is set properly, the furnace will provide enough heat to protect the water system. In severe cold however, it is wise to monitor the water temperature in the tank and take appropriate steps to drain and winterize if necessary. In weather below freezing, it may be necessary to open the lower cabinet doors at night in both the bath and kitchen areas to keep warmer air circulating around the water pipes, drainpipes, and fixtures. Always ensure you have an adequate supply of LP fuel to keep the furnace operational and regularly test your CO/LP detector to ensure breathable air inside the motorhome remains safe.
- If your motorhome is left unheated for any length of time during cold weather conditions, you must winterize the water system. This includes draining the holding tanks, water supply lines, and water heater. Use RV antifreeze to protect water lines and drainpipes that may still contain water. Refer to the water system winterizing procedures outlined in this manual.
- In cold weather conditions, it may be best to carry cooking and drinking water with you in plastic bottles or jugs instead of using the on-board freshwater system. If you decide to use bottled water, be cautious of water being placed down drains or being flushed through the toilet. Water that remains in P-traps and holding tanks is susceptible to freezing. If available, use campground bathroom facilities.

NOTE: Cold weather additives to on-board propane will ensure proper operation of your furnace, water heater and other gas appliances. Consult with your propane dealer about the anti-freezing properties of the propane you purchase.

Sanitizing the Freshwater System

CAUTION

WHEN USING CHLORINE, FOLLOW THE CAUTIONS ON THE BOTTLE LABEL:

- Chlorine is poisonous to humans and animals. Keep children and pets away from area when performing sanitizing procedures.
- Chlorine may burn skin. Use rubber gloves.
- Use safety glasses or face shield to protect eyes from material splashing.
- Chlorine splashed onto clothing can fade colors.

CAUTION

- Chlorine solutions may damage components of some water heaters and heat exchangers. It is recommended to bypass the water heater when sanitizing the freshwater system.
- Chlorine solutions may damage the filtration cartridge of some water filters and/or water treatment devices. Bypass water filters, or remove filter cartridges prior to sanitizing treatment, or replace filter cartridge when sanitizing procedure is completed.

NOTICE

DO NOT CONNECT YOUR WATER SUPPLY HOSE TO THE CITY WATER PORT OF YOUR MOTORHOME WHILE PERFORMING THIS PROCEDURE. The freshwater holding tank could be bypassed, preventing proper sanitizing and flushing of the freshwater system.

Be sure to only use a diluted chlorine solution as a sanitizer and flush the water system thoroughly. Recap bottle and clean-up any utensils or appliances with soap and water.

It is vital to regularly sanitize the freshwater system of your motorhome. This procedure will help keep the water system fresh and the water supply safe for drinking, while discouraging the growth of viral and bacterial contamination.

THE FRESHWATER SYSTEM MUST BE SANITIZED AND DISINFECTED:

- Upon delivery of the motorhome;
- At least once per year during continuous use;
- Prior to using the motorhome after it has been unused for prolonged periods of time;
- And, if you suspect the freshwater system has been contaminated in any way.

DO NOT POUR BLEACH STRAIGHT INTO THE FRESHWATER HOLDING TANK. Chlorine bleach must be diluted with clean, freshwater before it can be used as a safe sanitizing agent.

Prepare a solution of 1/4 cup household liquid chlorine bleach (5% sodium hypochlorite) to one gallon of water for every 15 gallons of tank capacity.

Examples:

- Prepare 1 gallon of solution for a 15 gallon tank.
- Prepare 1-1/4 gallons of solution for a 20 gallon tank.
- Prepare 2 gallons of solution for a 30 gallon tank.

This mixture creates a 50 PPM (parts per million) residual chlorine concentration for the sanitizing process. This will act as quick-kill dosage for some harmful bacteria, viruses, and slime-forming organisms. Concentrations higher than 50 PPM may damage water lines and metal components.

Sanitizing Procedure:

1. Turn off the water heater at the main switch and close the LP tank valve. **BYPASS THE WATER HEATER. CHLORINE CAN DAMAGE WATER HEATER COMPONENTS!**
2. Open all faucets and drain the freshwater holding tank by opening the tank drain valve. Close all faucets and the tank drain valve after the freshwater tank is empty.
3. With the fresh tank empty and all faucets and drains closed, pour the sanitizing solution into the freshwater holding tank via the gravity fill port. Be sure to add the proper amount of solution, depending on the size of your freshwater holding tank.
4. Top-off (completely fill) the freshwater holding tank.
5. Turn the water pump switch ON. Open all faucets (cold and hot) until the air is purged and water flows freely.
6. Close all faucets and top-of the freshwater holding tank again.

Allow the system to stand undisturbed for at least 3 hours.

After the time period has ended:

7. Drain and flush the entire system by opening all faucets, the freshwater tank drain valve and the low point drain valves, while running the water pump AND adding potable water through the freshwater gravity fill port.

Be sure there is a continuous supply of fresh, potable water flowing into the gravity fill port while performing

this flushing process. Using the City Water port would not flush the freshwater holding tank!

8. Continue this flushing process for several minutes and until the chlorine odor is not detected at the faucets.
9. Close all drain valves and faucets and fill the freshwater holding tank as you normally would. Make sure the water system is purged of air.
10. If chlorine is still detected, repeat steps 7, 8, and 9.
11. Finally, close the water heater bypass valve(s) and confirm that the water heater's storage tank is full before turning on the water heater.

Winterizing the Water System

WARNING

Automotive antifreeze (ethylene glycol) and windshield washer antifreeze (methanol) are poisonous. Never use these products in your freshwater system. These products are harmful and may be fatal if swallowed.

Only use biodegradable RV antifreeze to winterize your motorhome's freshwater system.

CAUTION

Do not operate the water heater or use the motorhome's plumbing system after the water system has been winterized.

NOTICE

Antifreeze can be damaging to internal components of the water heater. For proper water heater winterizing, drain the water heater tank and bypass the water heater inlet before adding antifreeze to the freshwater system.

IMPORTANT! READ AND FOLLOW THE MANUFACTURER'S INSTRUCTIONS FOR WINTERIZING THE FURNACE/WATER HEATER. THESE INSTRUCTIONS ALSO INCLUDE IMPORTANT SAFETY AND MAINTENANCE PROCEDURES FOR THE UNIT.

Preparing for colder weather or storage is an extremely important part of routine motorhome maintenance. The motorhome should be winterized at the end of the camping season, or when exposed freezing and below freezing temperatures (32°F; 0°C). Repairs due to freezing liquids are not covered by warranty. Add only RV antifreeze to the freshwater system to ensure freeze protection.

1. Level the motorhome and drain the freshwater system.
 - a. Locate and OPEN the drain valve for the freshwater holding tank
 - b. Locate and OPEN the low point drain valves for both the hot and cold water lines.

NOTE: Low point drains may be water features such as exterior showers or spray ports.

2. Turn OFF the furnace/water heater switch on the controller or multiplex panel.
3. Drain the water heater. Refer to the water heater manufacturer's instructions for winterizing procedures.
4. Turn OFF the main gas valve (solenoid) and at the furnace/water heater (if a second valve is installed).
5. Remove or by-pass the potable (drinking) water filter (if equipped).
6. Turn the water heater bypass valves (if equipped) to the BYPASS position. **DO NOT ADD ANTIFREEZE TO THE WATER HEATER.**
7. Close the freshwater holding tank drain valve and both low point drains valves.
8. Attach a short length of water hose to the city water fill (6 to 8 foot) and insert the other end of the hose into a gallon container of RV antifreeze (this quantity should be enough to winterize the motorhome). To assist the siphoning process, place the container on an object so that it is approximately two feet above ground level.
9. Turn the water pump ON. If the water pump fails to self-prime, temporarily open the low point drains. Close the low point drains as soon as the water pump primes (RV antifreeze will begin draining out), and before continuing to the next step.
10. Open hot water faucets one at a time, beginning with the faucet furthest away from the water pump, until RV antifreeze begins to steadily flow out (kitchen, lavatory, shower, clothes washer, exterior shower and spray ports). Then, close the faucet. Repeat for each hot water faucet.
11. Perform the previous step with all interior and exterior cold water faucets and spray ports.

NOTE: Allow enough antifreeze to flow so that the drain traps are filled with antifreeze.
12. Pour a cup-full of antifreeze down the shower drain.
13. Flush the toilet a few times until antifreeze is visible in the bowl.

When you are finished adding RV antifreeze:

14. Remove the water hose from the city water port and stow-away any remaining RV antifreeze.
15. To prevent staining, wipe the RV antifreeze out of the sinks, shower, and toilet using a soft, dry cloth.

NOTE: Do not operate the water heater or use the motorhome plumbing system after the water system has been winterized.

De-winterizing the Water System

1. Drain the holding tanks (fresh, gray, and wastewater tanks).

NOTE: If you do not have access to a sewage inlet, only drain the fresh and gray holding tanks. DO NOT drain the black holding tank onto the ground.

2. Open the low point drain valves and drain the water lines of antifreeze. Opening a hot and cold faucet will help drain the water lines more effectively.
3. Close the low point drain valves and all holding tank drain valves.
4. Attach a potable water hose to the freshwater fill and fill the freshwater holding tank.
5. Turn ON the water pump switch and open the cold water side of all faucets and shower fixtures. Shut OFF the faucet and shower fixtures after the water runs clear (no pink residue) and repeat for the hot water side.
6. Flush the toilet until clear water runs into bowl.
7. Empty the holding tanks again.
8. Sanitize the freshwater system.
9. If a potable (drinking) water filter has been installed: drain the water lines, remove the assembly, clean and reinstall using a new potable (drinking) water filter cartridge.
10. When ready to use the water heater, open the bypass valve allow water to enter and fill the water heater tank.

NOTE: The water heater bypass valve must NOT be in the BYPASS position for normal water heater operation.

NOTE: Although RV antifreeze is biodegradable, consider using a catch basin under the low point drain and freshwater holding tank outlets to collect and properly dispose of used antifreeze solution.

Wastewater System

The wastewater system of your motorhome consists of bathroom fixtures, drainage plumbing, wastewater holding tanks, drainage vents, and sewage valves. It is important to familiarize yourself with the motorhome's wastewater system, for it does require monitoring, routine, and long-term maintenance.

Toilet

NOTICE

Some RV toilets have a black tank full signal, which prevents flushing water from entering the bowl until the black tank has been emptied. Check with the manufacturer or your dealer to determine whether the toilet installed has this feature.

Follow all manufacturer's instructions associated with the toilet, regardless of type; including preparation, use, waste disposal, cleaning, maintenance, cold weather use, winterization, and storage.

The toilet installed in your motorhome is designed to provide convenient and trouble-free operation when used properly. Unlike most residential toilets, RV toilets are tank-less, meaning that the user fills the bowl just prior to use. Most toilets are operated by a foot-actuated pedal, located either on the right side or front of the toilet bowl. The toilet installed in your motorhome may differ than the illustrations included in this manual. Always follow the manufacturers operating instructions.

To use:

1. Turn ON the on-board water pump or connect the water system to an external pressurized source.
2. Add water to the toilet bowl by stepping partially down and holding the fill/flush pedal until the bowl is about 1/2 full.
3. To flush: press the fill/flush pedal completely down until the bowl empties.
4. Monitor the black waste tank levels and empty when full.

It is a good practice to always check and flush (empty) the toilet bowl before departure. Water remaining in the toilet bowl could slosh onto the bathroom floor while traveling.

NOTES - Applies to all types of RV toilets:

- **IMPORTANT** - Only use RV or Marine toilet paper with your motorhome's waste system. These paper products are specially formulated to break-down more readily than standard toilet paper products and help prevent waste system clogging.

- Do not flush hygiene, paper towels, plastics, or other non-biodegradable wastes into the wastewater system.
- Do not allow the black waste tank to become over-filled, resulting in an unsanitary spill-over.
- The toilet manufacturer may also recommend using cleaning products or chemicals that deodorize or aid waste decomposition.

Cassette Toilet (if equipped)

The bath in several Class B motorhome floor plans includes a cassette. When a cassette toilet is installed, the motorhome will not have a black water holding tank. However, the motorhome will have a gray wastewater tank which collects wastewater from the shower and sinks.

Preparing the cassette toilet for use:

The cassette toilet requires special attention in order to maintain safe and efficient use. Before using the toilet and after emptying the waste cassette, the waste cassette must be properly prepared. Doing so will ensure sewage waste does not clog the waste cassette:

1. Remove the waste cassette through the service door (see emptying the waste cassette).
2. Place the waste cassette upright and turn the spout upwards and remove the cap.
3. Add the proper amount of manufacturer's treatment chemicals to the cassette. Do not add treatment chemicals through the toilet bowl; these chemicals can damage seals.
4. Add approximately 3 liters of water to the cassette.
5. Replace the cap, turn the spout to its stowed position, and return the waste cassette to its stowage bay.

Using the cassette toilet:

1. Turn ON the on-board water pump or connect the water system to an external pressurized source.
2. The toilet bowl can be rotated for user comfort. Close the toilet cover, grasp the toilet bowl with both hands and rotate to the desired position.
3. Open the blade by moving the blade handle from left to right. The blade handle is located on the front of the toilet bowl. The toilet can be used with the blade open or closed.
4. Flush the toilet:
 - a. Ensure the blade is open.
 - b. Press and hold the flush button for several seconds. The flush button is located along the back or side of the toilet.
 - c. Close the blade after use.

Portable Toilet

Select TMC Class B motorhomes are equipped with a portable toilet. The toilet consists of two halves, joined together by a latch mechanism. The top half contains the seat, toilet bowl, freshwater tank (for flushing), and a manual pump to provide flushing water pressure. The lower half consists of a waste tank, flush valve, and tank level indicator.

This self-contained toilet is easy to operate and not difficult to empty. Instructions for using and maintaining the portable toilet are available from the TMC Owners Resource on-line document service, included in the TMC Class B Supplement, or available from the manufacturer's website.

NOTES:

- The manufacturer recommends to always use a portable toilet treatment solution, which helps break down solid wastes. It is also highly recommended to use RV or Marine-type toilet paper to help reduce the possibility of clogging the waste tank.
- The portable toilet provided with your motorhome may differ from these illustrations, but operation is similar. Consult the manufacturer's information for detailed operating and maintenance instructions.



Waste holding tank (separated from the top half of the toilet). This illustration shows the emptying spout, which is on a swivel to help facilitate emptying the tank.

Wastewater Holding Tanks

Your motorhome is fitted with waste holding tanks designed to collect wastewater and waste solids. Typically, wastewater from kitchen sinks, bathroom sinks and bathroom shower(s) is collected and stored in the gray water tank, while solids from bathroom toilet(s) is collected and stored in the black water tank. Depending upon the floor plan layout, bathroom gray wastewater may also drain to the black water tank. Some Class B models have a cassette toilet, where the cassette serves as the black water tank.

Wastewater collection tanks have valves that allow for emptying the tanks into an external sewage collection facility, commonly known as a 'dump station.'

NOTES:

- When traveling, it is good practice to minimize the wastewater (gray and black) carried in your motorhome. This will allow for carrying capacity for other items, if needed. Refer to Section 5, Occupant and Cargo Carrying Capacity (OCCC).
- Monitoring the level of fresh and wastewater is provided on the Multiplex touchscreen panel, typically indicated in 1/3 increments (except for models with a cassette toilet).

Termination Valves and Sewage Discharge

NOTICE

The termination valve assembly limits ground clearance of the vehicle. To prevent damage, use caution when encountering rough pavement, curbs, speed bumps, etc.

The components of the sewage discharge system are located underneath and to the rear of the motorhome. Configurations vary due to model and floor plan, but all function the same.



Typical termination valve layout

Campsite Sewer Hook-up

NOTICE

For sanitary reasons, never use a potable water hose for any wastewater dumping or sewer clean-up procedures.

When connected to a campsite sewer system, it is best to keep the termination valves CLOSED until the wastewater storage tanks need to be emptied.

Doing so provides two benefits:

1. **Prevents campground sewer gases from entering the motorhome through the wastewater system.**
2. **Helps retain some fluidity in the black tank, which helps to keep solid wastes suspended, preventing solid waste buildup on the tank's interior surfaces.**

Many campgrounds offer wastewater discharge at the campsite or if not, an on-site dump station. If your campsite has a wastewater discharge, it is usually located on the driver's side of the site, along with the electrical and freshwater connections.

1. Park the motorhome close enough to the sewer inlet so that your sewer hose will reach from your motorhome's sewer discharge to the campsite's sewer inlet.
2. Ensure **BOTH** Black a Gray water termination valves are **CLOSED** (handles are fully IN).
3. Remove the cap on the motorhome's sewage discharge outlet.
4. Connect the sewer hose to the motorhome's wastewater discharge outlet, ensuring the clips on the sewer hose engage the tabs on the outlet.
5. Place the other end of the sewer hose into the campsite sewer inlet. Often, a heavy object, like a rock or piece of firewood is needed to help secure the hose into the sewer inlet.



Typical sewer hose connection. Slip hose onto outlet and twist to lock.

However, there may be locations where the campsite's sewer inlet is too far away for your sewer hose to reach. In these situations, a sewer hose extension is needed. Sewer hose extensions are available from RV retailers.

Emptying Wastewater Holding Tanks

Whether emptying wastewater tanks at a campsite sewer inlet or at a campground dump station, follow this procedure:

1. Before emptying the wastewater holding tanks, check the level of the black tank. It should be at least 3/4 full. This will help insure the tank empties efficiently. If necessary, add water to the tank by flushing the toilet a few times.
2. Remove the cap from the sewer drain and connect the flexible sewer drain hose, ensuring the clips on the hose connector engage the tabs on the sewer discharge outlet.
3. Place the other end of the flexible sewer drain hose into the dump station inlet. Be sure both ends of the flexible sewer drain hose are secured.
4. Drain the black water holding tank **FIRST** by pulling the **BLACK** termination valve handle away from the valve body. Be sure to allow sufficient time for the wastes to k to completely drain from the tank, then rinse the black water holding tank with several gallons of water by depressing the toilet flush pedal (flush handle) or better yet, use the black tank flush (if equipped).

NOTE: See following section for Black Tank Flush procedure.

5. Drain the gray water holding tank by pulling the **GRAY** termination valve handle away from the valve body. Draining the gray water holding tank after the black tank allows gray water to rinse solid waste from the flexible sewer drain hose.
 6. When both the black water and gray water tanks are emptied, close the termination valves; **GRAY VALVE FIRST, THEN THE BLACK VALVE**, by pushing the handles back to the closed positions.
- NOTE: DO NOT** close the Black termination valve until black tank flushing procedure is complete and water source is turned OFF.
7. Remove the flexible sewer drain hose from the sewer drain outlet and while the other end of the sewer hose is still in the dump station inlet, rinse it thoroughly with clean water from a garden hose, or if available, the motorhome's exterior shower or spray port. Most dump stations provide a water hose spigot.

8. Lift the free end of the sewer hose, allowing it to drain completely into the dump station inlet. Then, remove the sewer hose from the dump station inlet and stow it in its storage container.
9. Replace the sewer caps onto the motorhome's sewage outlet and replace the cap or cover on the dump station inlet.
10. Spray off any sewage spills before disconnecting and stowing the garden hose.
11. Flush the toilet a few times to add a small amount of water to the black tank. This will help keep any remaining solid wastes from drying or adhering to the tank surfaces.

NOTE: Always wear rubber or vinyl gloves and protective eye wear when emptying the holding tanks and never use a potable water hose for wastewater dumping or clean-up procedures.



Location of Termination valves is typically on the left side of the motorhome. Class B camper-vans with cassette toilets will not be equipped with a black wastewater termination valve.

Gray Wastewater Tank

Floor Plans without a Black Wastewater Tank

NOTICE

The Sewage Hose Storage Bay could be damaged by speed bumps or other road hazards. Always be conscious of road conditions and the potential of under-carriage damage to low-mounted devices.

On floor plans without a black wastewater storage tank, a gray wastewater tank is installed. To empty the gray wastewater tank:

1. Open the sewage hose storage compartment, located along the lower left side of the motorhome (Figure 1). Extract the sewage hose and place the end of the hose into the sewage disposal inlet (Figure 2).
2. Pull open the gray handle on the termination valve.
3. When the wastewater stops flowing, close the termination valve and open a faucet in the motorhome (either the bath or kitchen) for a short period to place a gallon or so of rinse water into the gray wastewater tank.
4. Turn off the faucet and open the termination valve to rinse and empty the gray wastewater tank.
5. When rinse water stops flowing, close the termination valve and stow the sewer hose.

Figure 1



Figure 2



Emptying the Toilet Cassette

NOTICE

- **Do not allow the waste cassette to become too full.**
- **To prevent water damage to your motorhome, do not travel with a waste cassette that is more than 3/4 full. This may cause leakage through the venting system.**
- **The manufacturer's toilet additives are environmentally safe to empty into septic and sewage disposal systems.**

The cassette toilet has a built-in level indicator that indicates when the waste cassette is full and requires emptying. When the slide turns from green to red, the waste cassette is full.

The toilet cassette is accessed by an external panel located on the left side of the motorhome (Figure 3).

1. Open the access panel door and press the blue latch to release the cassette (Figure 4).
2. Pull the cassette out of the cassette bay. Be careful not to drop the cassette, it may be heavy. NOTE: The cassette has a sealing mechanism that automatically closes the inlet when the cassette is removed from the bay (Figure 5).
3. Lower the cassette to the ground, placing it on its built-in wheels and extend the transport handle (Figure 6).
4. Transport the cassette to a sewage waste disposal site.
5. Rotate the discharge neck, uncap, and while pressing and holding the vent button with your thumb, empty the cassette in the sewer inlet.
6. Most sewage disposal sites have rinse water available. Rinse the cassette with approximately 5 liters of water, emptying the rinse water into the sewage inlet.
7. Remove the float from the waste cassette and rinse with clean water. Return the float mechanism to the waste cassette.
8. If it is desired to continue using the toilet, prepare the waste cassette for use as previously instructed.
9. Return the cassette to its storage bay. Be sure the carrying handle is collapsed, the discharge neck is capped and rotated to the stowed position, and the cassette latch is secured. Close the access panel door.

NOTE: Never use force if you cannot get the waste cassette back into its storage bay easily. If blockage occurs, always check to determine if the blade handle is in the closed position.

Figure 3



Figure 4



Figure 5



Figure 6



NOTE: Some Class B motorhomes have a bathroom with a cartridge toilet located at the rear of the vehicle. Access to the toilet cartridge is through the rear door.

Black Tank Rinse (if equipped)

⚠ CAUTION

DO NOT USE THE BLACK TANK FLUSH SYSTEM UNLESS THE BLACK TANK TERMINATION VALVE IS IN THE OPEN POSITION.

The black tank could overflow into the motorhome if the termination valve is not open, which will result in an unsanitary condition, possibly leading to illness or potential personal injury.

After black tank dumping, some solids may be left at the bottom of the black water tank as well as on the tank sidewalls. The black tank rinse is designed to help flush the black tank of waste solids. To use:

1. Ensure the sewer hose is connected to the motorhome's sewer outlet and the dump station inlet.
2. Connect a garden hose (reserved for this task) to the dump station water supply and the black tank rinse port. For sanitary reasons, **DO NOT USE YOUR POTABLE FRESHWATER HOSE FOR THE BLACK TANK RINSE OR OTHER WASTEWATER CLEAN-UP PROCEDURES.** Do not turn the rinse water ON until the black tank has emptied.
3. Ensure the black tank termination T-valve is OPEN.
4. Turn ON the rinse water and let the water run for several minutes. During the rinsing/flushing process, be sure the termination valve remains open and the flexible sewer drain hose remains connected between the motorhome's sewage drain outlet and the dump station inlet.
5. When rinsing/flushing is complete, turn off the water supply. Disconnect the water hose from the black tank rinse port.
6. Close the black tank termination valve.
7. Disconnect the sewer hose from the motorhome. While the other end of the sewer hose is connected to the dump station inlet, rinse the sewer hose, inside and out, with water from the dump station's water supply. Let the rinse water drain into the dump station inlet.
8. When complete, stow the sewer hose and rinse hose.

Without Black Tank Flush:

If the motorhome does not have a black tank rinse system, you can use water from the toilet bowl to rinse the black holding tank:

1. Ask your partner to flush the toilet several times, placing clean rinse water into the black tank. Do this immediately after dumping the black tank and while the flexible sewer hose is still connected to the sewer outlet of the motorhome and to the dump station inlet. The black termination valve must remain OPEN.
2. This rinsing process may need to be done several times. When finished, close the black termination valve, clean and stow the sewer hose.



Typical black tank flush

Section 12: Heating and Cooling

Introduction

Your motorhome's heating and cooling system consists of equipment sourced from a variety of manufacturers, yet the individual components are designed to function as an integrated system. Depending on floor plan and available features, the furnace installed in your Class B motorhome may provide for room heating only or consist of an appliance that combines room heating and water heating into a single unit. Air-conditioners also vary in style, depending on floor plan and available features. Heating and cooling components may have manufacturer's warranties that require product registration. Your dealer can assist you with component registrations.

Detailed information regarding the heating and cooling equipment that is uniquely specific to your motorhome is not covered in this manual. Please review and retain all manufacturer's owner's manuals and documentation that is included with your TMC Owner's Packet. The manufacturers of the heating and cooling equipment installed in your motorhome are the best source for information regarding component features, operation, and maintenance.

Always refer to the manufacturer's documentation if you have questions regarding your heating and cooling system. TMC Customer Care representatives are also available to answer any question you may have. Call toll free:

877-855-2867

NOTES:

- Class B motorhomes with gasoline engines are equipped with the propane-fired Truma combination Furnace/Water Heater.
- Class B motorhomes with diesel engines are equipped with the diesel-fired Aqua-Hot Combination Furnace Water Heater.
- State and local laws may restrict the use of propane appliances while the vehicle is in motion. Be sure to follow all regulations regarding the transportation of propane gas.
- For additional information regarding heating and cooling systems installed on your motorhome, please refer to the TMC HVAC System Guide, TMC Class B Supplement, and the HVAC manufacturer's product information available through the TMC on-line Owners Resource Information Service:

www.thormotorcoach.com/owners/

Truma Combination Furnace/Water Heater

WARNING

CARBON-MONOXIDE POISONING HAZARD!

Failure to follow instructions could result in severe personal injury or death due to carbon-monoxide poisoning if combustion gases enter the RV.

Check that all openings in the outside wall around the vent (and air intake) pipe(s) are sealed to prevent combustion gases entering the RV.

Check that furnace vent and air intake are not obstructed in any way.

Never operate the combination furnace/water heater when the vehicle is parked in an enclosed or confined space.

This combination furnace/water heater presents danger of hot surfaces and hot gases. Do not touch the area around the wall cowl and do not lean any objects against the wall cowl (furnace exhaust).

NOTICE

Damage to the Combi furnace can be caused by freezing!

The Combi furnace does not have a frost-protection function. If the heating is not used and there is a risk of freezing, all water must be drained from the water container (refer to "Draining the water container").

IMPORTANT! Read and follow the manufacturer's instructions regarding safety, operation, maintenance, and winterization of the furnace/water heater.



Truma Combi Furnace/Water Heater

TMC Class B motorhomes (camper-vans) are equipped with a factory-installed LP-fueled combination furnace and water heater, designed specifically for small recreational vehicles. The furnace/water heater combination unit is a tank design and holds a volume of 2.6 gallons of water. Some models use a combination of LP gas and electric to rapidly heat water and provide warm air.

Safe Operational Procedures

- Shut OFF gas and the LPG tank when moving the RV. This disables all gas appliances and pilot lights. Gas appliances must never be operated while vehicle is in motion.
- Shut OFF the Combi furnace when refueling (gasoline or diesel) or refueling propane (LPG).
- To avoid damage, make sure no spray water enters the Combi furnace when cleaning the RV, e.g., do not spray directly into the wall cowl (inlet/exhaust port).
- Switch OFF the gas supply and the Combi furnace if anything seems to be out of the ordinary.
- Only a qualified service technician may perform routine cleaning, repairs, and maintenance. Have a qualified service technician immediately remedy any malfunctions.
- Any alteration to the Combi furnace or its controls can cause unforeseen serious hazards and will void the manufacturer's warranty.
- After a long period of winterizing flush all hot/cold water hoses and the Combi furnace thoroughly with safe, potable water before using it.
- The Main Propane Valve must be ON along with the propane switch located on the unit (see Propane Section).
- Room air is drawn into the furnace by a fan, heated up and distributed to the RV's interior.
- Pressurized water is supplied to the water tank by the on-board water pump (assuming there is water in the freshwater holding tank) or by pressurized city water.
- A comfortable water temperature at all water spigots is reached by mixing both hot and cold faucets.
- A wall vent allows combustion air to flow into the furnace and exhaust gas to flow out.

IMPORTANT! NEVER BLOCK OR OBSTRUCT THE INLET AIR AND EXHAUST VENT LOCATED ON THE SIDE OF THE MOTORHOME.

For complete safety, operational, and maintenance information on the furnace/water heater unit installed in your motorhome, please refer to the manufacturer's instructions contained in your Owner's Packet or visit the water heater manufacturer's website. Product information is also available in the TMC Class B Supplement Guide and from the on-line TMC Owners Resource Information Service. TMC Customer Care representatives are also available to answer any question you may have; call, toll free at:

877-855-2867.

*NOTE: Do not allow water to freeze within the furnace/water heater unit. When winterizing the water system, the water tank of the unit **MUST** be drained. **DO NOT** use compressed air to drain the unit. Do not place anti-freeze solutions in the tank of the furnace/water heater unit.*

Freeze damage is not covered under either the manufacturer's or TMC warranty.

How the Combi Furnace/Water Heater Functions

The Combi furnace was developed exclusively for use in recreational vehicles (RVs). The Combi is a furnace with a supplementary, indirect hot water heater. The unit can be used without water, as a furnace only, or if water is present in its tank, it will function as a water heater and furnace.

Controlling furnace and water heater functions is done through the CP Controller.

All Combi models are fueled by propane and a require 12-volt DC power supply. Important Operational Notes:

- The Main Battery Disconnect Switch must be ON.
- If 30-amp Shore Power is available, connect to it; this will eliminate auxiliary battery drain.

Operating Instructions

WARNING

SCALDING INJURIES CAUSED BY HOT WATER!

Water temperatures over 127° F (52° C) can cause severe burns or scalding and in extreme cases even death.

Water in the hot water container can become as hot as 162° F (72° C) during operation. If there is a malfunction, the water can reach 205° F (96° C).

- Always use potable water to fill the hot water container. The person operating the furnace is responsible for the quality of this water.
- Before using a hot water faucet or using the shower, allow the hot water to run until the water temperature no longer increases and mix with cold water.
- Test the temperature of the water before placing a child in the bath or shower.
- Do not leave a child or an infirm person in the bath unsupervised.

NOTICE

DANGER OF FAULTY OPERATION!

Always use the CP Plus control panel to operate the Combi furnace. Operating instructions for the CP Plus control panel are included in your Owner's Packet and available through the on-line TMC Owners Resource.

NOTICE

To avoid damage to the Combi unit, only a 120 volt AC sine-wave generator may be used. 120/220 volt AC shore power is also acceptable.

READ AND FOLLOW THE "CONSUMER SAFETY INFORMATION" (CONTAINED WITHIN THE MANUFACTURER'S INSTRUCTIONS) BEFORE OPERATING THE COMBI FURNACE.

Selectable Modes of Operation:

The CP Plus control panel (Fig. 1 – B) is used to switch between modes of operation (refer to the CP Plus Controller manual for additional instructions).

1. **Heating mode:** The furnace automatically selects the proper operating level based on the difference between the desired temperature set at the control panel and the current room temperature. If there is any water in the water container, it will be heated automatically. The water temperature will not be regulated, but it will reach a maximum of 162 °F (72 °C).
2. **Hot water mode (only if water container contains water):**
Hot water mode is ideal if only hot water is required. The lowest burner setting suffices for heating water. In hot water mode, the burner will switch off as soon as the water reaches the temperature selected in the CP Plus control panel.

Both modes of operation can be combined.

Selectable Modes of Power Input:

The CP Plus control panel is used to select various modes of energy for the Combi eco plus and Combi comfort plus models.

No Combi furnace operates in any mode without a 12 volt DC power source.

1. **LP gas for gas mode**
All Combi furnaces run on LP gas (propane).
2. **Electricity for electric mode**
The Combi eco plus and Combi comfort plus furnaces can be powered by electricity if the RV is connected to shore power or a generator.
3. **LP gas and electricity (mixed mode)**
The Combi eco plus and Combi comfort plus furnaces run simultaneously on LP gas (propane) and electricity.

If the selected operating mode is:

1. **Heating mode:** The Combi eco plus and Combi comfort plus run simultaneously with LP gas (propane) and electricity.
2. **Hot water mode:** The Combi eco plus and Combi comfort plus run in electric mode with a preselected power output setting of 850 W (Mix 1) or 1700 W (Mix 2).

When the RV is disconnected from a 120 volt AC source,* the furnace will automatically switch to LP gas (propane).

* As long as there is a sufficient supply of 12 volts DC and LP gas (propane).

Gas Shut-off Valve Switch

The switch (Fig. 4) shuts off the power to the safety gas shut-off valve and with this the gas supply to the Combi furnace. To make sure that the gas supply to the furnace is off, turn the switch to the OFF position.

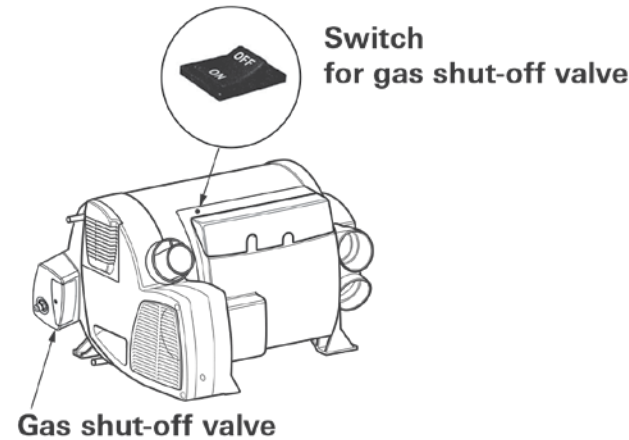

Figure 4

Switch Positions of the Switch for Gas Shut-off Valve:

OFF = gas shut-off valve is closed

ON = gas shut-off valve is open

NOTE: This switch does not affect gas supply to other gas appliances within the motorhome, nor does it affect the main gas valve switch of the motorhome.

Room Temperature Sensor

A room temperature sensor (Fig. 1 – C) measures the temperature inside the RV.

The installation location for the room temperature sensor depends on the model and floor plan.

Truma Pressure Relief/Drain Valve

⚠ WARNING

RISK OF SCALDING INJURY FROM HOT WATER AND/OR TAMPERING WITH THE PRESSURE RELIEF/DRAIN VALVE!

- **Never actuate the pressure relief/drain valve as long as the Combi furnace is still hot.**
- **Do not place a plug or reducing coupling on the outlet part of the valve. If you use a discharge line, allow.**

The Truma pressure relief/drain valve provides both the pressure relief function and a drain function.

- The pressure relief/drain valve is a safety component and must not be removed for any reason other than replacement.
- The pressure relief/drain valve is not serviceable; if defective, it must be replaced. It must be replaced by a certified service technician.
- It must only be replaced by the Truma pressure relief/drain valve rated for 65.25 psi (4.5 bar) which is CSA certified and registered.
- Tampering with the pressure relief/drain valve will void the warranty.

The Combi furnace with supplementary indirect water heating must be installed with the Truma pressure relief/drain valve (Fig. 5) that complies with the standard for Relief Valves for Hot Water Systems, ANSI Z21.22.

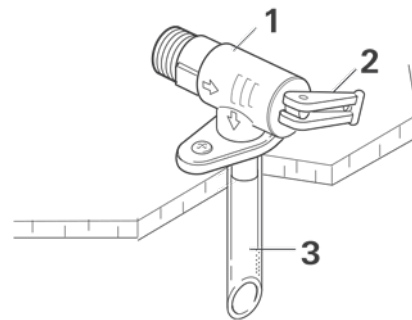

Figure 5

1. Truma pressure relief/drain valve
2. Lever
3. Drainage socket (extends through RV's undercarriage to outside)

Opening the Truma Pressure Relief/Drain Valve

NOTICE**DANGER OF DAMAGE TO THE COMBI AND THE RV DUE TO AN OBSTRUCTED DRAINAGE SOCKET!**

The drainage socket (Fig. 5 – 3) must be unobstructed and kept clear of obstructions such as slush, ice, or leaves to ensure that water can drain properly. No warranty claims for frost damage will be accepted.

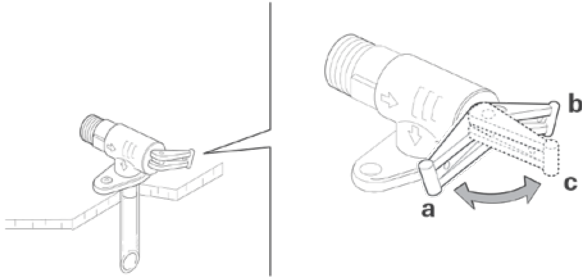

Figure 6

- Move the lever so that it is in the “draining” position (Fig. 6 – c). Water will drain from the hot water container via the drainage socket (Fig. 5 – 3).

Closing the Truma Pressure Relief/Drain Valve

- Move the lever so that it is in the “closed” position (Fig. 6 – a or 6 – b)

a,b = lever in “valve closed during furnace operation” position

c = lever in “draining” position

Starting the Combi Furnace

WARNING**DANGER OF OVER-TEMPERATURE AND TOXIC EXHAUST GASES!**

- Use with LP gas (propane) only. Butane or any mixtures containing more than 10 % of butane must not be used.
- Keep the air inlet and exhaust gas outlet free of obstructions. Do not lean any objects against the wall cowl on the RV or place any objects within a range of 2 feet (61 cm) of the wall cowl.

WARNING**DANGER OF COMBUSTION AND DAMAGE TO PERSONS AND THE MOTORHOME!**

- Keep the area around the Combi furnace free from combustible materials, gasoline, and other flammable vapors or liquids.
- Switch the gas supply and the Combi furnace off:
 - If anything seems to be out of the ordinary.
 - If you smell gas.
 - If you move the motorhome.
 - Before entering a gas station.
 - Before entering a tunnel.
 - Before entering a ferry boat.

Inspections Before Each Use

Check the Combi furnace for the following points before each use. In case of damage, contact an authorized Truma service provider and do not operate the Combi furnace.

- Inspect the furnace (Fig. 1 – A), exhaust venting system (Fig. 1 – F), and wall cowl (Fig. 1 – F) for damage. Verify that connections are tight and fasteners are secure.
- The wall cowl (Fig. 1 – F) for drawing in combustion air and emitting exhaust must be free from obstructions such as slush, ice or leaves. The furnace will not function properly if the combustion-air inlet or exhaust tube is partially or completely obstructed.
- The warm air outlets (Fig. 1 – H), the wall outlet vents (Fig. 1 – I) and the openings for the circulated air intake (Fig. 1 – D and Fig. 2 – 11) must be free from obstructions to ensure that the furnace functions properly. Any obstructions might cause the furnace to overheat. If this happens, the built-in temperature limiter will interrupt the flow of gas to the furnace. Once the furnace has cooled, it will switch on again automatically.
- Access to adequate quantities of LP gas (fuel inlet pressure 11 – 13 in. wc (27.4 – 32.4 mbar)) and 12 volts DC power must be available.
- Make sure that the shore power voltage’s fuse protection of the campground suffices for operating the furnace in electric mode. The furnace needs up to 1,700 watts (14.2 amps) in operating mode 2. If the supply voltage’s fuse protection is not sufficient, the furnace can be operated in operating mode 1 with up to 850 watts (7.1 amps).

Filling the Water Container

NOTICE

DAMAGE TO THE WATER CONTAINER!

The water pressure on the inlet side must be limited to 40.6 psi (2.8 bar), otherwise internal components of the appliance will be damaged. On (city) water connections with a pressure higher than 40.6 psi (2.8 bar) a pressure regulator is strongly recommended.

1. Close the pressure relief/drain valve, if open (refer to "Closing the Truma pressure relief/drain valve").
2. Close open bypass lines, if present.
3. Turn on the fresh water supply or switch on the water pump.
4. Fill the plumbing system:
 - › Open all water-release points, e.g. cold and hot water faucets, showers, toilets.
 - › Once water flows, the plumbing system is purged of air.

Switching ON the Furnace

WARNING

SCALDING INJURIES CAUSED BY HOT WATER!

Water temperatures over 127° F (52° C) can cause severe burns or scalding and in extreme cases even death.

- Before using a hot water faucet or using the shower, mix with cold water and allow the hot water to run until the water temperature no longer increases.
- Test the temperature of the water before placing a child in the bath or shower.
- Do not leave a child or an infirm person in the bath unsupervised.

WARNING

SCALDING INJURIES CAUSED BY HOT AIR!

Ventilation air can reach 250° F (121° C) at the warm air outlet and it can cause severe burns or scalding and in extreme cases even death.

- Always check the air temperature before varying the air throttle position (Fig. 1 – H).

1. Switch ON the main battery disconnect switch.
2. If necessary, fill the water container with water (refer to "Filling the water container"). If no hot water is needed, the Combi furnace can be operated without being filled.
3. Make sure the supply of LP gas is turned on at the main gas valve.
4. Make sure the gas shut-off valve, on the Combi unit, is switched ON (refer to "Switch for gas shut-off valve").
 - › Operation without gas supply is possible for the Combi eco plus and the Combi comfort plus (120 volt AC). The maximum heating power is then 1,700 watts.
5. Use the CP Plus control panel to switch on the Combi furnace (refer to the CP Plus manual for additional instructions).
 - › There may be a variation between the temperature delivered from the Combi furnace and the temperature at the faucet due to water conditions or the length of pipe from the Combi furnace.
 - › The presence of a flow restrictor in the hot water line may limit the water flow.
6. If using hot water:
 - › Use the CP Plus control panel to select the desired water temperature level.
 - › To obtain the desired water temperature at the faucet or in the shower, mix cold and hot water.
 - › Make sure that the water temperature has stabilized before any person or animal enters the shower.
7. If using hot air:
 - › Use the CP Plus control panel to set the desired room temperature.

NOTE: For the furnace to work properly, there must be enough LP gas (propane > 11 in. wc) and 12 volts DC power. Optionally, for electric or mixed mode with the Combi eco plus and Combi comfort plus, an additional 120 volts AC power supply is needed.

Switching OFF the Furnace

1. Switch off the Combi furnace using the CP Plus control panel. Due to internal processes, it may take some time until the furnace is completely shut down.
2. If the Combi furnace and any other gas-powered device is not needed anymore, turn OFF the LP main gas valve.

3. Switch off the Combi furnace's electrical power supply (main battery disconnect switch, unless other 12 volt devices are being used).
 - › If you intend to put the RV into storage or if you switch off the Combi furnace during freezing temperatures, refer to the "Winterizing" section.

Draining the Water Container

NOTICE

DAMAGE TO THE COMBI FURNACE CAUSED BY FREEZING!

The Combi furnace does not have a frost-protection function. The water container must be drained if the motorhome will not be used whenever there is a risk of frost.

No warranty claims for frost damage are accepted by the manufacturer or Thor Motor Coach.

To make sure that all water drains properly from the water container, place a big enough vessel underneath the drainage socket of the pressure relief/drain valve (> 2.64 gallons (10 liters)).

1. Use the main battery disconnect switch or pump switch to switch OFF the power to the water pump.
2. Turn off or disconnect the city water connection, if present.
3. Open all water release points, e.g. cold and hot water faucets, showers, toilets.
4. Open the pressure relief/drain valve (refer to "Opening the Truma pressure relief/drain valve").

The water container will drain via the drainage socket of the pressure relief/drain valve.

NOTE: This procedure will not drain the entire water system. Refer to Winterizing in the Water Section of your Owner's Manual, or the TMC Water System Guide.

Winterizing

NOTICE

SEVERE DAMAGE TO THE PLUMBING COMPONENTS AND THE COMBI FURNACE IS POSSIBLE!

- Damage due to freezing or an unsuitable winterizing fluid is not covered by warranty.
- Follow the recommendations below if the Combi furnace will be stored under freezing conditions or for an extended period of time.
- Winterize the Combi furnace at the start of the winter season or before traveling to a location where freezing conditions are likely.

DRAINING THE WATER HEATER/FURNACE DOES NOT FREEZE PROTECT OTHER WATER SYSTEM COMPONENTS!

To properly protect the entire water system from freezing temperatures, the fresh water tank, fresh water lines, drain lines, toilet, and waste water holding tanks must be winterized.

Refer to the winterizing section of this manual, or the winterizing sections of your TMC Class B Owner's Manual or TMC Water System Guide.

For winterizing, drain the Combi furnace, refer to "Draining the water container."

After draining the water, the Combi furnace is protected against freezing conditions.

Optional: Winterizing the RV with a Winterizing Fluid

1. Drain the water container (refer to "Draining the water container" on page 36).
2. Turn the valves of the bypass kit according to the supplier's or RV manufacturer's guidelines.
3. Flush the water system with a suitable winterizing fluid according to the supplier's or RV manufacturer's guidelines.
 - › Before using the Combi furnace again in hot water mode, remove the winterizing fluid and flush the water system with potable water.

NOTE: Winterizing the RV with a winterizing fluid is only possible with an installed bypass kit (not included in the scope of these instructions). Refer to the water system section of your Class B Owner's Manual.

Winter Operation

To operate the Combi furnace in potentially freezing conditions, the following requirements must be ensured:

- There must be sufficient LP gas (propane; fuel inlet pressure 11 – 13 in. wc (27.4 – 32.4 mbar)) in the tank.
- In addition, the Combi eco plus and Combi comfort plus models require a supply voltage of 120 V if they are to be operated in electric or mixed mode.
- For hot water operation, the water container must be filled (refer to “Filling the water container” on page 12). You must leave the furnace powered ON whenever freezing might occur.

Winter operation will not protect the RV’s entire plumbing system. The RV must be prepared for freezing conditions. Refer to ‘Cold Weather Use of the Water System,’ contained in the Water Section of your Owner’s Manual.

Maintenance and Storage

It is recommended to have the following service done once a year:

- Replace the fuel filter.
- Check the air ducting, air intake, and exhaust outlet for blockages or damage.
- Check for damage or breaks in the fuel lines and wiring.

If the system has not been used for long periods of time, thoroughly flush all hot/cold water lines before use. It is recommended to run the heater at least once a month for 10-20 minutes to ensure optimum heater condition.

The water tanks must be cleaned regularly, minimum of twice a year. Whether the motorhome is in use or storage, the temperature range should not fall below -40° F (-40° C) or rise above +185° F (+85° C) to prevent damage to the electronic components of the system.

Aqua-Hot Combination Furnace/ Water Heater

(Diesel-powered Class B Motorhomes)

WARNING

- Follow all manufacturer's operation and maintenance instructions exactly. If not, a fire or explosion may result, causing property damage personal injury, or death.
- In order to avoid overheating the furnace/water heater unit, do NOT cover the heater or any vents, inlets, or outlets.
- The heating system can produce dangerous CO gas if not properly operated by following the manufacturer's instructions. Read all safety instructions before operating the furnace/water heater.
- Regularly check the combination CO/LP Alarm for proper functionality.
- Do NOT use bio-diesel with the fuel lines of this unit. Doing so will result in damage to the burner and fuel system. Always check for any fuel leaks before operating the burner.
- Do NOT operate the furnace/heater combo unit in a confined space, such as a garage, workshop, or other enclosed building.
- Exhaust ports and other surfaces are very HOT and can cause severe burns. Do NOT touch or service until the unit has sufficiently cooled.

CAUTION

- Use caution when working on or near any diesel fuel system.
- Use special caution when children are present. Children must not be allowed to play with the heater or perform cleaning or maintenance.
- At maximum operating temperature, the hot air outlet will be very hot, which may result in serious burns or injury. Be aware of hot surfaces.
- The burner produces very hot temperatures that can ignite surrounding flammable materials. The burner should be turned OFF when loading or unloading flammable materials.
- This unit must have a cold water inlet pressure regulator set to 45 PSI or below to avoid damage to the unit's water tank.
- Read and follow the manufacturer's instructions regarding safety, operation, maintenance, and winterizing the furnace/water heater.

NOTICE

DAMAGE TO THE AQUA-HOT FURNACE/WATER HEATER CAN BE CAUSED BY FREEZING!

The Aqua-Hot furnace/water heater does not have a frost-protection function. If the heating is not used and there is a risk of freezing, all water must be drained from the water container (refer to 'Draining the water container,' information available from the manufacturer or TMC's Class B Supplement.

NOTICE

The components of this water heater are not compatible to prolonged exposure to sodium hypochlorite (household bleach). Using products containing bleach, including water refreshers, may cause corrosion of the water lines and internal components, resulting in catastrophic failure of the Aqua-Hot system by creating leaks that cannot be repaired. This damage is not covered by the Aqua-Hot warranty.

When disinfecting the water system, bypass the hot water tank of this unit.

Your diesel-powered TMC Class B motorhome may be equipped with a combination furnace/water heater manufactured by Aqua-Hot. This unit provides interior and hot water using a diesel-fired burner and a supplementary electric heating element. Diesel fuel is drawn from the vehicle's fuel tank. The heater can be used while the vehicle is in motion.

Safe Operational Procedures

- Shut OFF the Aqua-Hot furnace when refueling (gasoline or diesel) or refueling propane (LPG).
- To avoid damage, make sure no spray water enters the Aqua-Hot furnace when cleaning the RV, e.g., do not spray directly into the wall cowl (inlet/exhaust port).



Aqua-Hot Gen 1 Furnace/Water Heater

- Switch OFF and do not use the Aqua-hot furnace if anything seems to be out of the ordinary.
- Only a qualified service technician may perform routine cleaning, repairs, and maintenance. Have a qualified service technician immediately remedy any malfunctions.
- Any alteration to the Aqua-Hot furnace or its controls can cause unforeseen serious hazards and will void the manufacturer's warranty.
- After a long period of winterizing flush all hot/cold water lines and the Aqua-Hot furnace/e thoroughly with safe, potable water before using it.

Operational Notes

The Aqua-Hot Gen 1 is a furnace with a supplementary, indirect hot water heater. The unit can be used without water, as a furnace only, or if water is present in its tank, it will function as a water heater and furnace.

Controlling furnace and water heater functions is done through the wall-mounted controller.

- The Main Battery Disconnect Switch must be ON.
- If 30-amp Shore Power is available, connect to it; this will eliminate auxiliary battery drain.
- The motorhome's diesel fuel tank must be filled to more than 1/4 full.
- Room air is drawn into the furnace by a fan, heated up and distributed to the RV's interior.
- Pressurized water is supplied to the water tank by the on-board water pump (assuming there is water in the freshwater holding tank) or by pressurized city water.
- A comfortable water temperature at all water spigots is reached by mixing both hot and cold faucets.
- A wall vent allows combustion air to flow into the furnace and exhaust gas to flow out.

IMPORTANT! NEVER BLOCK OR OBSTRUCT THE INLET AIR AND EXHAUST VENT LOCATED ON THE SIDE OF THE MOTORHOME.

For complete safety, operational, and maintenance information on the furnace/water heater unit installed in your motorhome, please refer to the manufacturer's instructions contained in your Owner's Packet or visit the water heater manufacturer's website. Product information is also available in the TMC Class B Supplement Guide and from the on-line TMC Owners Resource Information Service. TMC Customer Care representatives are also available to answer any question you may have; call, toll free at:

877-855-2867.

*NOTE: Do not allow water to freeze within the furnace/water heater unit. When winterizing the water system, the water tank of the unit **MUST** be drained. **DO NOT** use compressed air to drain the unit. Do not place anti-freeze solutions in the tank of the furnace/water heater unit.*

Freeze damage is not covered under either the manufacturer's or TMC warranty.

Winterizing

To avoid freeze damage to the furnace/water heater, the unit must be drained through the drain valve completely. If water is left in the system in below freezing temperatures, it can cause severe damage to the system that is not covered under warranty.

- Turn off power supply and open hot water faucets.
- Place a container under the drain valve to catch the water from the heater's tank (approximately 2.5 gallons).
- Open the drain valve and allow the water to drain out completely.

It is recommended to winterize if the motorhome will be stored for a long time or the system will not be used, or if the ambient temperature will drop below freezing.

NOTE: The Aqua-Hot can continue to be used for interior heat once the water system has been winterized.

Maintenance and Storage

It is recommended to have the following service done once a year:

- Replace the fuel filter.
- Check the air ducting, air intake, and exhaust outlet for blockages or damage.
- Check for damage or breaks in the fuel lines and wiring.

If the system has not been used for long periods of time, thoroughly flush all hot/cold water lines before use. It is recommended to run the heater at least once a month for 10-20 minutes to ensure optimum heater condition.

The water tanks must be cleaned regularly, minimum of twice a year. Whether the motorhome is in use or storage, the temperature range should not fall below -40° F (-40° C) or rise above +185° F (+85° C) to prevent damage to the electronic components of the system.

Furnace/Water Heater Controller

WARNING

Use the control panel only when it is in a technically sound condition.

- Have a specialist immediately remedy any malfunctions. Remedy the malfunction yourself only if a remedy is specified in the troubleshooting chart in these operating instructions.
- Have a defective control panel repaired only by the manufacturer or its service department.
- Any alteration to the appliance or its controls can be dangerous and will void the warranty.

Combination Furnace/ Water Heater wall-mounted controller



Display and Operating Elements

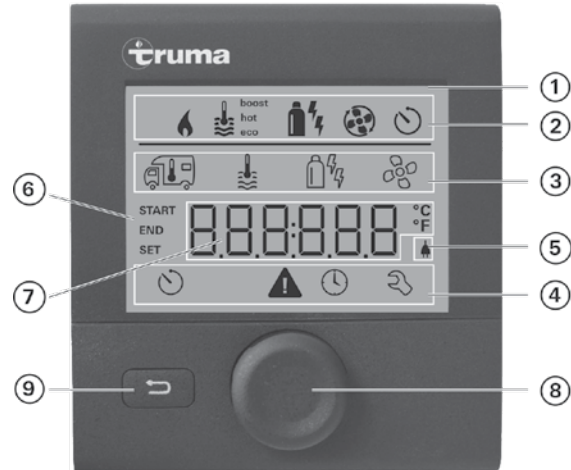

Figure 1

1. Display
2. Status line
3. Menu line (top)
4. Menu line (bottom)
5. Power supply display (120-volts AC shore power)
6. Time switch display
7. Settings/values
8. Rotary push button
9. Back button

Both the Truma Combi and Aqua-Hot Furnace/Water Heaters are operated by a panel-mounted controller with similar functions and control features. Depending on the floor plan of the motorhome, this control panel is typically mounted on a cabinet or wall surface.

IMPORTANT! Read and follow the manufacturer's instructions regarding safety, operation, maintenance, and winterizing of the furnace/water heater and control panel.

Description

- A rotary push button (8) is used to select menu items in the menu lines (3 + 4) and to adjust settings.
- Information is shown on a backlit display (1).
- The Back button (9) is used to go back to a previous menu.
- Complete operational instructions are available through your on-line TMC Owners Resource account.

 + **TURN CLOCKWISE**

- The menu is scrolled through from left to right
- Increase values (+)

 - **TURN COUNTERCLOCKWISE**

- The menu is scrolled through from right to left
- Reduce values (-)

 **TAP**

- Save a selected value
- Select a menu item, go to the setting level

 **PRESS (3 SECONDS)**

- Main switching function – control panel on/off

Controller Operation

Following is an abbreviated description of some of the controller's functions. For complete information about the CP controller, its functions, and settings, please refer to the manufacturer's information available through your TMC Owners Resource on-line document service.

Control Panel ON/OFF:

Press the rotary push button (8) for more than 3 seconds.

- Previously set values and operating parameters are active again when the panel is switched on.
- When you switch off the control panel, any Truma Combi device that is connected is also switched off automatically.
- Because of internal time lags for the heating, the switching-off process can take a few minutes.

Select Setting Level:

Tap the rotary push button (8).

- The display shows the setting level. The first icon flashes

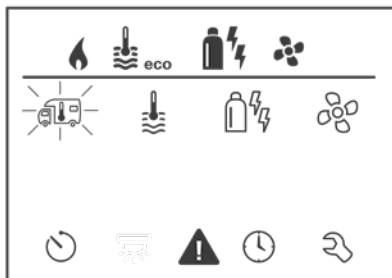

Functions:

The functions of menu lines (3, 4) of the CP plus control panel can be selected in any sequence. The operating parameters are shown in the status line or in the displays (5, 6).

Change Room Temperature:

- Use the rotary push button (8) to select the icon in the menu line (3).
- Tap the button to go to the setting level.
- Select the desired temperature with the rotary push button (8).
- Tap the rotary push button (8) to confirm the value.
- The temperature can be changed quickly using the rotary push button (8) (on the stand-by screen).

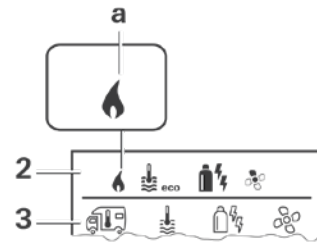

Adjustable temperature range:

Temperature display	Range	Increments
Fahrenheit	40-86° F	1° F
Celsius	5-30° C	1° C

a = Furnace* is switched on

* This icon flashes until the desired room temperature is reached.

Change Hot Water Level:

- Use the rotary push button (8) to select the icon in the menu line (3).
- Tap the button to go to the setting level.
- Select the desired hot water level with the rotary push button (8).
- Tap the rotary push button (8) to confirm the value.

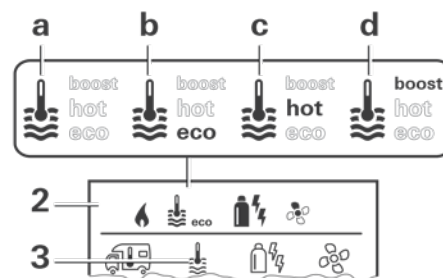

a = Boiler*

b = eco**

c = hot

d = boost*

- Hot water generator is ON.

- Water temperature 104° F (40° C).

- Water temperature 140° F (60° C).

- Boiler content is heated quickly (boiler priority) for up to 40 minutes. The water temperature is then kept at the higher level (about 144° F (62° C) for two subsequent heating cycles. When the water temperature is reached, the room is heated again.

* This icon flashes until the desired water temperature is reached.

** The water temperature 104° F (40° C) can be kept in "Heating and hot water mode" for a limited time only (heating priority).

Select Energy Mode:

- Use the rotary push button (8) to select the icon in the menu line (3).
- Tap the button to go to the setting level.
- Select the desired energy mode with the rotary push button (8).
- Tap the rotary push button (8) to confirm the value.

When the furnace is switched on (room temperature, hot water level active), the energy mode selected in the previous heating process is shown in the status line. The factory setting is gas.

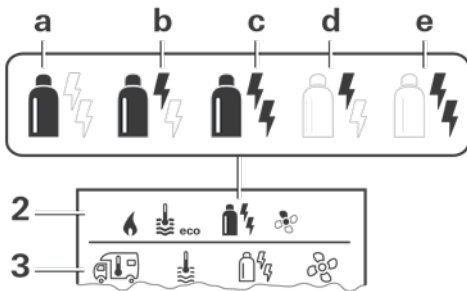

Icon	Operating Mode	Energy Mode
a	LP gas	LP gas
b	MIX 1 *	Electricity 850 W + gas
c	MIX 2 *	Electricity 1700 W + gas
d	EL 1 *	Electricity 850 W
e	EL 2 *	Electricity 1700 W

* Mixed mode and electricity mode Possible only with Truma Combi eco plus and Truma Combi comfort plus furnaces with electric heating elements.

Special Features in Mixed Mode:

- Interruption in the 120 VAC power supply:
The furnace automatically switches to gas mode. When the 120 VAC power supply is restored, the furnace automatically switches back to mixed mode.
- Fault in combustion process (e.g. fuel shortage):
The furnace automatically switches to electric mode. If the furnace is to run in mixed mode again, the cause of the malfunction must be remedied and the furnace has to be started again by going to the menu item 'Malfunction' and pressing the rotary push button. See Malfunction.

Special Features in Electricity Mode:

- When the 120 VAC power supply is interrupted and the 12 VDC supply is on, an error code is displayed on the control panel.
- When the 120 VAC power supply is reconnected, the furnace will restart automatically with the previous settings without any user interaction. The error code on the control panel will disappear.

Select Fan Speed:

- Use the rotary push button (8) to select the icon in the menu line (3).
- Tap the button to go to the setting level.
- Select the desired fan speed with the rotary push button (8).
- Confirm with the rotary push button (8).

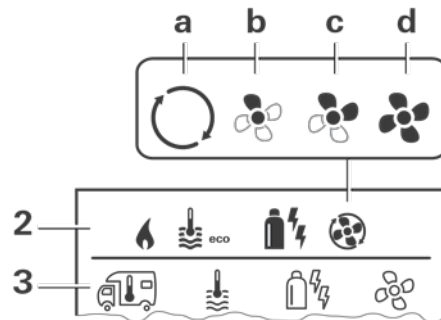

Icon	Operating Mode	Description
–	OFF	Fan is switched off (can be selected only if furnace is switched off)
a	VENT *	Circulating air, if furnace is switched off. Speed can be selected in 10 increments
b	ECO	Low fan speed
c	HIGH **	High fan speed
d	BOOST	Fast room heating available if the difference between the selected and the current room temperature is > 180 F (100 C)

* Can increase wear and tear on the motor, depending on how often it is used.

** HIGH fan speed uses more electricity, is louder, and increases wear and tear on the motor.

NOTE: When the furnace is switched ON (room temperature, hot water level set), the fan speed selected in the previous heating process is shown in the status line (2). The factory setting is ECO.

Set the Time Switch:

WARNING

RISK OF CARBON MONOXIDE POISONING!

The enabled time switch turns the furnace on, even when the recreational vehicle (RV) is parked. The exhaust gas from the furnace can cause poisoning in enclosed spaces (e.g. garages, repair shops).

If you park the RV in an enclosed space:

- Shut off the gas feed to the furnace.
- Disable the time switch (OFF).
- Switch the furnace off. (On the Truma CP plus control panel, press the rotary push button (8) for 3 seconds.)

Important Reminders:

- The time switch can be selected only if the clock was set on the control panel.
- If the time switch is ON, the “Disable time switch (OFF)” menu is displayed.
- Use the rotary push button (8) to select the icon in the menu line (4).
- Tap the button to go to the setting level.

Enter the Start Time:

- Use the rotary push button (8) to set the hours and then the minutes.
- If the start/end time is later than the time when you entered the settings, the operating parameters are not active until the next start/end time is reached. Until then, the operating parameters set outside the time switch remain valid.

24 h mode

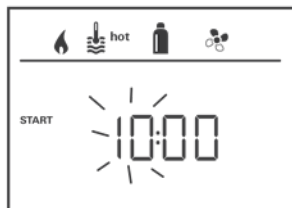

12 h mode



A = a. m.
P = p. m.

Enter the End Time:

- Use the rotary push button (8) to set the hours and then the minutes.
- If the start/end time is later than the time when you entered the settings, the operating parameters are not active until the next start/end time is reached. Until then, the operating parameters set outside the time switch remain valid.

24 h mode



12 h mode

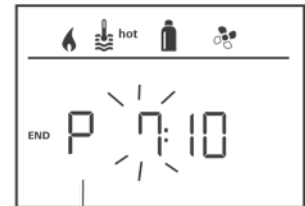

A = a. m.
P = p. m.

Set the Room Temperature:

- Select the desired room temperature with the rotary push button (8).
- Tap the rotary push button (8) to confirm the value.

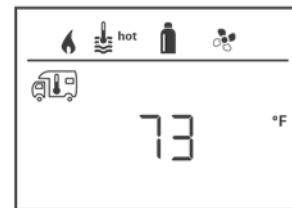

Example: Temperature display in °F

Set the Hot Water Level:

- Select the desired hot water level with the rotary push button (8).
- Tap the rotary push button (8) to confirm the value.



Select Energy Model

- Select the desired energy mode with the rotary push button (8).
- Tap the rotary push button (8) to confirm the value.
- The “Select energy mode” menu is displayed only if a furnace with electric heating elements is connected (Truma Combi eco plus or Truma Combi comfort plus).

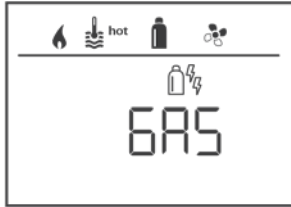

Select Fan Speed:

- Select the desired fan speed with the rotary push button (8).
- Tap the rotary push button (8) to confirm the value.
- The “Select fan speed” menu is displayed only if the room temperature was set.

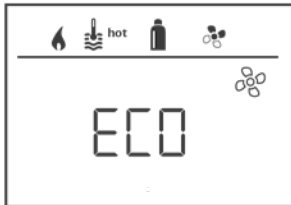

Enable the Time Switch (ON):

- Enable the time switch (ON) with the rotary push button (8)
- Tap the rotary push button (8) to confirm the value.
- The time switch remains enabled, even for several days, until it is disabled (OFF). If the time switch is programmed and enabled, the time switch icon is shown in the status line (2). If the time switch is active, the icon flashes.

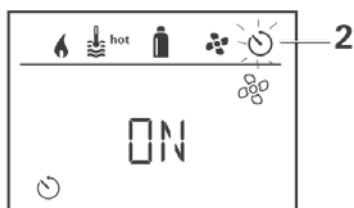

Disable the Time Switch (OFF):

- Tap the rotary push button to go to the setting level.
- Disable the time switch (OFF) with the rotary push button (8)
- Tap the rotary push button (8) to confirm the value.



Set Clock:

- Use the rotary push button (8) to select the “Set clock” icon in the menu line (4).
The hour display flashes.
- Use the rotary push button (8) to set the hour.
- Tap the rotary push button (8) again and the minute display flashes.
- Use the rotary push button (8) to set the minutes.
- Tap the rotary push button (8) to confirm the value.

Display 24 h mode

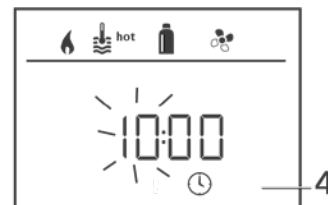

Display 12 h mode

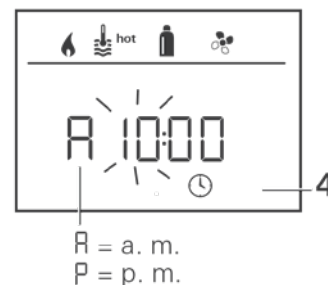

Roof Air Conditioner

NOTICE

The information included in this section comes from the air conditioner manufacturer and pertains to general installations. Depending on motorhome brand and floor plan, installations may differ from these instructions.

Most Class B motorhome models are equipped with a 120-volt AC roof-mounted air-conditioning unit that is controlled from the multiplex touchscreen panel. To operate the air-conditioner, the motorhome must either be connected to shore power, powered by the on-board generator, or powered by the optional Re(Li)able battery system (through that system's special inverter; see Electrical Section). Due to the electrical load of an air-conditioner, they are not powered by the standard inverter that is supplied with a generator system.

General Information

The air conditioner installed in your motorhome is designed to operate from a 115 VAC, 60 HZ, 1 Phase power supply. Anytime an air conditioner is not operating properly, the power supply should be examined by a qualified technician to verify that the air conditioner is receiving the proper electrical power.

The ability of the air conditioner to maintain the desired inside temperature depends on the heat gain of the recreational vehicle.

The size of the vehicle, amount of window area, amount of insulation, direct exposure to the sun, outside temperature and the number of people in the recreational vehicle may increase the heat gain to such an extent that the capacity of the air conditioner is exceeded.

As a general rule, air entering the air conditioner will be cooled about 15 to 20 degrees, depending on the outside temperature and humidity conditions.

For example, if the air entering the return air grilles in the air conditioner is 80 degrees F., the air leaving the discharge grilles in the air conditioner will be 60 to 65 degrees F.

As long as this temperature difference is being maintained between the return air and discharge air, the air conditioner is operating at its capacity. If the desired inside temperature (normally 80 degrees F) cannot be maintained, then the heat gain of the RV is too great for the capacity of the air conditioner.

Parking the vehicle in a shaded area, keeping windows and doors shut and avoiding the use of heat producing appliances

in the vehicle will help to reduce the heat gain. When possible, the addition of insulation and tinted glass (especially in uninsulated vans) should be considered.

High Pressure Switch Lockout Circuit:

Air conditioners and heat pumps using R410A refrigerant may utilize a factory installed High Pressure Switch Safety Circuit. In the event of an abnormal condition (failure of fan motor, dirty condenser coil, dirty filters), the high pressure switch will prevent the compressor from continuing to run. Once the high pressure switch has tripped, this safety circuit will "Lock Out" the compressor preventing it from trying to restart or run until the 115 VAC supply power has been turned off and then back on to reset the High Pressure Switch Safety Circuit. If repeated trips of the high pressure switch lock out occur, then you must have the unit serviced by a qualified technician.

Control Panel:

If your RV air conditioner is operated from the control panel located in the ceiling assembly, then there are three controls on the ceiling assembly that help you control the air conditioner. They are as follows:

- The Selector Switch – The selector switch determines which mode of operation the air conditioner will be in. By rotating the selector switch, the operator can obtain any system function desired. System functions vary depending upon options of both the roof top unit and ceiling assembly. Figure 1 shows selector switch location and lists all available functions by model.
- The "Operation" section explains the operational characteristics of each mode of operation.
- The Thermostat (temperature control) – In the cooling mode, the thermostat regulates the "ON" and "OFF" temperature setting at which the compressor will operate.



Typical Rooftop air-conditioner Unit. Temperature control is integrated into Multiplex touchscreen controller.

For “Heat/Cool” models, the thermostat also controls the “ON” and “OFF” temperature settings of the heater assembly (See Figure 1).

- Louvers – The louvers are located at both ends of the ceiling assembly shroud and are used in directing the discharge air from the unit.

Multiplex temperature setting:

1. Locate the Climate Menu on the multiplex panel.
2. Select Air-conditioning, and;
3. Set the desired temperature.

The air-conditioner will cycle on and off to maintain the desired inside temperature.

NOTE: If equipped, an air-conditioning unit can draw a significant amount of energy from the Re(Li)able battery system in a relatively short time period. Frequent battery recharging may be necessary.



Set the desired air conditioned temperature from the Climate Menu on the Multiplex Touchscreen Controller.

Cabinet Air Conditioner

Due to limited roof space, some Class B models are equipped with a cabinet-style air-conditioning unit. Operational controls are NOT integrated with the multiplex system. On/Off and temperature controls are located on the top panel of the unit. For convenience, the unit also is supplied with a hand-held remote control. The room-style air-conditioner is powered by 120-volt AC, either by shore power, generator, or the optional Li-ion battery system, through an inverter.

Typical cabinet-style air-conditioner



For complete operating and maintenance instructions, please refer to the manufacturer’s instructions included in your TMC Owner’s Packet, or available through the complementary TMC Owners Resource Information Service.

NOTES:

- Air-conditioners are designed to cool approximately 20 degrees Fahrenheit lower than the outside ambient air. On extremely hot days, the air-conditioner may not be able to cool the motorhome to the desired temperature.
- During warm weather, it is best to start the air-conditioner early in the day, allowing it to cool-down and keep the interior of the motorhome at a comfortable temperature before the outside temperature becomes too warm.

Ceiling and Ventilation Fans

Your vehicle may be equipped with high-volume ceiling and ventilation fan(s). If equipped, the fan(s) can be operated as a powered vent; to draw in cool outside air, or as a ceiling fan to circulate the inside air of the motorhome. The fan is equipped with a translucent rain cover.

Refer to the TMC HVAC System Guide for complete operational and maintenance instructions pertaining to motorhome ventilation and fan operation. Also refer to the Care and Maintenance Section of this manual for important condensation information.

This page is intentionally blank

Section 13: Care and Maintenance

Chassis (Vehicle) Maintenance

For information regarding proper maintenance and other important chassis details, refer to the vehicle manufacturer's owner's manual. As the owner, you are responsible for taking proper precautions when attempting any repair or maintenance for your motorhome. If you are not sure what action to take or are uncomfortable with performing a maintenance or repair function, contact your selling dealer, or a designated chassis manufacturer servicing dealer for assistance. Contact your chassis manufacturer for information on locating a service center near you.

NOTES:

- *All issues regarding the chassis (vehicle) warranty, parts, and service should be directed to the chassis (vehicle) Manufacturer.*
- *Follow the recommendations outlined in the chassis (vehicle) manufacturer's owner's manuals to ensure that proper safety, performance, and maintenance procedures are performed.*

General Maintenance

Periodic maintenance and cleaning of your motorhome is necessary to retain the dependability, safety, and appearance that will provide you with many years of trouble-free operation, as well as protecting your investment.

Make sure you read and follow all the maintenance tips, instructions, and schedules that are included in this manual and also in the manuals provided by the chassis manufacturer and component manufacturers. Keep good records of maintenance procedures performed, and make sure you perform all owner obligations as may be required to keep your warranties in force.

It is also important to note that operating conditions will affect service timetables. Driving in extreme conditions such as heavy dust, continuous short trips, or start and stop heavy traffic means that service durations will be shortened. Discuss service timetables with both your RV dealer and chassis service representative. Preventative maintenance will pay for itself many times over by catching or preventing problems before they occur. Often, repair costs are greatly increased due to a small problem left unattended, begins to affect other parts and systems of the motorhome.

If there are cleaning, maintenance, or procedures for which you are unsure of performing, please contact your dealer or chassis service representative for recommendations.

NOTE: Expenses and obligations of performing periodic maintenance service are not covered under Thor Motor Coach's Limited Warranties.

Mold Prevention

Molds are microscopic organisms that naturally occur in virtually every environment, both indoors and out. Outdoors, mold growth is important in the decomposition of plants. Indoors, mold growth is unfavorable. Left unchecked, molds break down natural materials, such as wood products and fabrics. According to the Center for Disease Control, exposure to damp and moldy environments may cause a variety of health issues. Some people are sensitive to molds. For these people, molds can cause nasal stuffiness, throat irritation, coughing or wheezing, eye irritation, or skin irritation. People with mold allergies may have more severe reactions. Immune-compromised people and those with chronic lung illnesses may develop serious infections in their lungs when they are exposed to molds.

For mold growth to occur, temperatures must be between 40° and 100° Fahrenheit (4.4° to 37.7° Celsius) and there must also be a source of moisture, such as humidity in the air, standing water, damp materials, etc. Indoors, the most rapid mold growth occurs when warm and humid conditions exist.

Inhibiting Mold Growth

The growth of mold and mildew can be inhibited by controlling relative humidity. In warm climates, use of the air-conditioner will reduce the relative humidity. Opening vents that are located in the bathing and cooking areas is advised during food preparation and bathing, even during cool or cold weather. Additionally, opening a window during these activities will assist in ventilation. In extremely humid conditions, the use of a dehumidifier (customer supplied) can be helpful in reducing air-borne moisture.

Frequent cleaning of your motorhome is an important preventive measure. Spills should be wiped up quickly and dried as soon as possible. Avoid leaving damp items lying about. On surfaces, use mold or mildew killing cleaning products (test cleaning product to ensure it will not damage surfaces). Check window, door, and joint seals regularly and repair or reseal when necessary to avoid water intrusion. Proper regular and preventive maintenance to the motorhome and its accessories will help prevent the formation of molds.

NOTE: For more information about controlling moisture in your motorhome, refer to Condensation, located in the TMC Care and Maintenance System Guide.

Condensation

Excess moisture trapped within your motorhome can cause severe long-term damage to laminates, surfaces, fixtures, and other components of your motorhome. Therefore, it is important to follow moisture-reducing procedures as a normal routine of motorhome ownership and maintenance.

Tips for Controlling Condensation

To avoid condensation-related problems, follow these tips to help reduce excess moisture:

- Allow excess moisture to escape to the outside, when bathing, washing dishes, hair drying, laundering, and using appliances and non-vented gas burners, by opening ceiling vents.
- Always use the vent hood when cooking (if equipped).
- Keep the bathroom door closed and the vent or window open or turn on the ventilation fan when bathing and for a period of time after bathing.
- Do not hang wet clothes in the motorhome to dry.
- In hot weather, start the air-conditioner early in the day as it removes excess humidity from the air while lowering the interior temperature.
- When operating the furnace, keep the temperature as reasonably cool during cold weather as possible. Doing so can help reduce condensation on cold exterior walls and windows.
- Use a fan to keep air circulating inside the motorhome so condensation and mildew cannot form in dead air spaces. When possible, leave cabinet doors partially open to aid air circulation.
- A natural tendency is to close the motorhome tightly during cold weather. This may actually increase inside humidity because warm inside air may be more humid than the cool outside air. Allowing some cool outside air into the motorhome may help reduce relative humidity inside the motorhome.

Seals and Sealants

The exterior shell of the motorhome is the primary weather and moisture barrier. Over the life of the motorhome, the shell will require regular care and maintenance. The shell includes the roof, sidewalls, windows, doors, and under carriage of the motorhome. Regular inspections and maintenance is required to ensure the exterior shell provides a barrier against water intrusion.

The shell should be inspected periodically for the condition of seals and sealants. Check corner and joint moldings for sealant damage. Areas that require maintenance should be resealed utilizing a high-quality sealant that has the same or similar characteristics as the original sealant.

Check door, window, and vent seals for cracks, chips or other damage and replace damaged seals as soon as possible. Extra care needs to be given to all roof-related seals to prevent water intrusion from the roof:

- Air-conditioner seal and/or gasket
- Roof racks
- Fans and vents
- All mounting points and wire ports

NOTE: Damage caused by lack of sealant maintenance is not covered under the Thor Motor Coach Limited Warranty.

Cleaning Interior and Exterior Surfaces

Regular cleaning and washing of the interior and exterior surfaces of your motorhome is vital to keeping your motorhome in a well-maintained condition. Specific details on cleaning and washing surfaces, as well as graphics and fabrics are covered in the TMC Care and Maintenance System Guide, available through your on-line TMC Owners Resource account.

Extreme Weather Use

General Vehicle Preparation

Cold and extreme climates present additional strains on electrical and mechanical systems. Prepare the engine, drivetrain, and chassis for cold or extreme weather as you would your automobile. Ensure all fluids are fresh and topped off. Ensure the cooling system is properly maintained with fresh antifreeze of the proper type and concentration. Ensure your vehicle's batteries are in good condition, along with the charging system.

Check all battery connections for tight fitting and remove any terminal corrosion.

Check tire pressures often. Hot and cold climates can affect proper tire inflation pressure.

Hot Climates

Ensure the vehicle's engine oil is the type recommended for the temperature range you will encounter. Also, be sure transmission fluids, are topped off and are regularly changed. Ensure engine oil and transmission coolers are in good working order.

Brakes can quickly overheat in hot climates. Ensure brake pad surfaces, brake drums and rotors are maintained in optimum working condition.

Cold Climates

Cold climates present challenges due to freezing temperatures on water systems of the motorhome. If you expect to encounter freezing temperatures, either winterize the water system, then afterward, prevent the system's use, or if the climate is mildly cold, then operate tank heaters (if installed). Operate the furnace to raise the inside temperature. Open cabinets to allow warm air to circulate around plumbing pipes and fixtures.

- Make proper preparations to avoid freeze damage to the freshwater and wastewater systems.
- Propane regulator freeze-ups can occur in any weather if there is moisture in the tank or if the tank has been over-filled. Always use moisture-free propane fuel and make sure the tank is not filled beyond 80% of capacity.
- During cool weather usage, ventilation, or the use of a dehumidifier (customer supplied) may be required to reduce condensation.
- To avoid damage due to cold weather, check the exterior for frozen moisture before operating or using the motorhome's doors, locks, windows, and vents.

NOTE: Damage caused by using your motorhome in freezing temperatures and/or performing deficient cold weather precautionary measures is not covered by Thor Motor Coach's Limited Warranties.

High Altitudes

High altitudes can affect the function of propane appliances and the propane system. Consult with your propane dealer if you anticipate using your propane system in high altitudes. The burner orifice may need to be modified, along with ensuring that there is little moisture content in the propane fuel.

Extended Stay Usage

NOTICE

Your motorhome is not designed, nor intended, for permanent housing. Use of your motorhome for long term or permanent occupancy may lead to premature deterioration of its structure, interior finishes, fabrics, carpeting, window treatments, etc.

Damage and/or deterioration due to long term occupancy is not considered normal and may, under the terms of the warranty, constitute misuse, abuse, or neglect, and therefore void certain warranty protections.

Your motorhome was designed primarily for recreational use and short-term occupancy. If you expect to occupy the motorhome for an extended period of time, be prepared to actively address condensation and the humid conditions that may be encountered.

The relatively small living space of an RV contributes to an environment where normal activities of even a few occupants can lead to rapid moisture saturation of the interior air. During cold weather, when relative humidity of the interior air is high, moisture condensation on surfaces can become significant. Estimates indicate that a family of four can vaporize up to three gallons of water daily through breathing, cooking, bathing, and washing.

Unless water vapor is carried outside by ventilation, or reduced by a dehumidifier (customer supplied), it will condense on the inside of the windows and walls of the motorhome. Moisture may also condense out-of-sight, within the walls or ceiling panels, where it can cause warping or staining. Appearance of these symptoms may indicate a serious condensation problem. Always take necessary action to minimize the effects of excessive moisture and condensation.

Long-term Storage of Your Motorhome

WARNING

Antifreeze treatment for the fresh water system must be nontoxic in nature and must be flushed from the fresh water system before human use. Automotive antifreeze is poisonous and SHOULD NOT be used in drinking water systems.

When storing your motorhome for the winter, extended periods, or in other extreme conditions it is important to take steps to protect the surfaces, mechanical and electrical components, fabrics, and systems from exposure to the elements and to prevent damage due to harsh weather or neglect. Make sure you talk with your local RV dealer concerning any special requirements for long-term storage in your geographical area.

A few hours spent preparing your motorhome for storage will pay great dividends in ensuring your motorhome will be ready for the next season of use. The ideal storage location of your motorhome would be in an enclosed, climate-controlled facility, however, this is not always possible. The following instructions will guide you in the steps that are necessary to prepare your motorhome for an extended storage period.

- Turn OFF and disconnect from all water sources.
- Turn OFF all combustion appliances.
- Winterize your motorhome's water system.
 - a. Drain and flush all holding tanks.
 - b. Drain the water heater tank and freshwater lines.
 - c. If freezing temperatures are expected, treat plumbing pipes and fixtures with RV antifreeze.
- Slightly open all closets, cabinet doors, and drawers; this allows for air circulation.
- Close all windows and entrance doors.
- Open a roof vent enough to allow for some limited ventilation, but not so far as to allow snow or rain to enter the motorhome.

When storing the motorhome in climates of high relative humidity (greater than 60%), control humidity inside the motorhome by operating a dehumidifier (customer supplied), drained to the exterior.

General Vehicle Preparation

Perform chassis maintenance and recommend storage procedures outlined by the chassis manufacturer (oil, filters, transmission inspection, tires, brakes, etc. Refer to the chassis manufacturer's owner's manual).

Take the time to thoroughly inspect the chassis and engine bay for broken, missing parts, or parts that need replacement. Before storage is a good time to replace burned-out bulbs, re-fill washer fluids, replace worn wiper blades, change air filters and make other routine maintenance repairs.

Tires:

Tires can be damaged by the harmful UV rays from the sun. Inflate the tires to the manufacturer's recommended cold pressure, and protect the tires with covers that will block out the sunlight. Liquid tire surface treatments, found in auto parts stores, may be used to give the tires a UV protective coating.

Brakes:

Brake fluid is designed to absorb moisture. Follow the chassis (van) manufacturer's recommendations for periodical flushing and changing the brake fluid. This procedure should be performed by a certified mechanic.

Battery(ies):

Battery maintenance is an important part of winter storage preparation. If you plan to start the unit while in storage and periodically plug into shore power, leave the batteries in the unit. Plugging it into shore power once a month for about eight hours will help keep the house batteries topped off. At a minimum, you should check and adjust the water levels in all batteries and make sure the batteries are fully-charged. A discharged battery will freeze much quicker than a fully-charged battery. If the RV is in long-term storage, it's better to remove the batteries and store them where they will not freeze. In either case, keep the batteries fully-charged when they are in storage.

- Be sure that both the chassis and auxiliary (coach) batteries have the proper electrolyte level and that they are fully charged. Add distilled water and recharge if necessary. (NOTE: batteries installed in your motorhome may be sealed or maintenance-free).
- Batteries should be checked for charge at least monthly. Use of a trickle-charger may be appropriate. Inquire with the battery manufacturer regarding trickle-charging methods. A discharged battery could freeze and may crack the case, causing severe damage to the battery and surrounding area. In storage, a battery will lose

charge gradually over a 30-to-45 day period, even when disconnected from the positive and negative battery cables.

- You may wish to remove the batteries from the motorhome and store them in a heated area (approximately 50–60° F; 10–15° C). However, even in warm storage, the battery charge level must still be maintained.

NOTE: Vehicles left in storage for extended periods of time require further provisions to maintain a proper state of charge of the vehicle batteries.

Parasitic loads from the radio, clock, powertrain control module, courtesy lights or other accessories will discharge a battery if the vehicle is not used for an extended period of time.

A discharged battery (lead-acid type) can actually freeze in temperatures of 32 degrees F (32°F), resulting in permanent damage to the battery. Batteries may also be permanently damaged if allowed to stand for long periods of time in a state of discharge.

Lithium battery power system:

Refer to the manufacturer's documentation for long-term storage and care of the Li-ion battery pack(s) and system along with the Winterizing Li-Ion Battery Systems section of this guide.

Fuel:

Fill the fuel tank prior to storage and add a fuel stabilizer. Run the engine and the generator long enough for the stabilizer to get through the entire fuel system. Change the oil and oil filter on the engine and the generator prior to storage. Acids accumulate in used engine oil and can corrode engine bearings, especially while sitting for long periods of time. If possible, exercise the generator for at least two hours every month with a minimum of a ½ rated load on it. Consult your generator owner's manual for load ratings.

Dash air-conditioner:

Operate the unit for a short period of time throughout the storage period to assure the compressor seal is lubricated.

Exterior

When you store your motorhome outside for extended periods, the exterior begins to show signs of wear from constant exposure to the elements. Ozone in the air and ultraviolet (UV) rays from the sun start to take their toll. Ozone causes the paint to fade and makes products like

rubber and vinyl dry out, crack and deteriorate. The UV rays from the sun make this aging process happen quicker.

Thoroughly clean exterior surfaces. Protect painted surfaces with a high-quality automotive wax. Protect vinyl and plastic surfaces with a product designed for these materials. Lubricate locks and hinges. Seal roof joints and mounting points as needed. Follow exterior cleaning guidelines outlined in the TMC Care and Maintenance System Guide, available through your on-line TMC Owners Resource account.

Paint chips and other surface damage:

Before storage is a good time to touch-up those nagging paint chips, repair surface scratches and other surface dings that are simply the result of road travel.

Windows:

Treat seals with silicone spray. Close and lock. Inspect exterior body seals and reseal if necessary.

Roof:

Inspect mounting points and ports. Reseal if sealant shows signs of shrinking, cracking, or has become hard or brittle.

If you have vent covers installed on the roof vents, that prevent rain from getting inside, leave them cracked open to allow for some ventilation.

Awnings, locks, and brackets:

Don't forget to clean the awning fabric, and let it dry completely before storing it. Ideally, you should try to store your motorhome under a covered area, and on a solid surface like pavement or concrete. If this isn't possible, avoid parking under trees and in tall grass, fields or wooded areas. Service all locks with a spray lubricant and lubricate all hinges.

Appliance vents:

Insects are attracted to the odorant added to LP gas, so you may want to cover LP gas appliance vents to prevent insects from making their winter home inside these vents. Remove nests created by pests and other debris. Inspect periodically throughout the storage period and keep vents open. If you do cover the vents, remember to remove the cover next spring.

Air-conditioner(s):

Remove air filters and clean or replace. Cover the exterior shroud.

Generator:

Prepare the generator for long-term storage as outlined in the manufacturer's instruction manual.

Water system:

Winterize the water system as outlined in the Water System Section of this manual.

Propane system:

- Inspect all hoses, pipes, valves, joints, and couplers for leaks. Refer to Propane Leak Test in Propane Section.
- Turn off all propane supply valves and appliances and keep vents open, while preventing vents and intakes from becoming blocked due to insects or rodent nests.
- After storage, inspect entire propane system, including vents, before use.

Electrical System

- If the RV is in long-term storage and won't be plugged in to electricity, turn off the main breaker in the power distribution panel.
- If batteries are to be trickle-charged during the storage period, ensure the inverter/charger or the converter is powered by a shore-power connection.
- Remove any dry cell batteries from devices like smoke alarms, clocks etc.

Interior

When RVs are stored for the winter, it's not uncommon for insects, mice and squirrels to make their winter home in the motorhome. Rodents are notorious for chewing through vehicle wiring, plastic and rubber components, resulting in extensive damage. What is needed is to prevent mice and other rodents from being able to access the motorhome. This can be difficult because they can enter through some very small openings. Start by inspecting the underside of your motorhome for any gaps or holes. Fill these gaps using silicone or expanding foam. Next, open drawers and cabinet doors inside the motorhome. Look in all of the corners and crevices, especially where plumbing and wiring enter or exit the motorhome. If you can see any daylight, mice can get in. Fill these areas with silicone or expanding foam.

Kitchen and storage areas:

- Remove all food items.
- Clean all interior surfaces and fabrics.
- Inspect the interior of the motorhome monthly while in storage to make sure leaks have not developed, or condensation has not formed that can cause damage to interior components. Condensation can most readily be observed as moisture accumulation on windows and

exterior surfaces. To reduce condensation, make sure to ventilate the motorhome during storage.

- Use insect and rodent repellents to protect against damage, following repellent manufacturer's guidelines. Test to ensure repellent will not damage surfaces.

Curtains and blinds:

Close all the drapes and curtains and protect the curtains from sun fading by placing foil or paper between the windows and the curtains/blinds.

Microwave, cooktop, and oven:

Clean interior and exterior surfaces with mild detergent and water. Wipe dry. Ensure all appliances are OFF.

Refrigerator:

Clean inside and outside surfaces. Leave doors propped slightly open to allow for air circulation. Leave an opened box of baking soda inside the refrigerator to prevent odors.

Sinks, toilet, and shower:

Clean with disinfectant and dry. Pour one cup of nontoxic RV antifreeze into the drains to prevent freezing. Wipe-up any spilled antifreeze from surfaces.

Additional Care and Maintenance Information

For additional information regarding the care and maintenance of your motorhome, please refer to your Chassis Manufacturer's Owner's Manual and TMC's Care and Maintenance Guide, and other documents and videos available to view and download from the TMC Owners Resource Information Service.

- Follow all maintenance instructions provided by the component manufacturers of the devices installed in and on your motorhome.
- Refer to the vehicle manufacturer's owner's and service manuals for care and maintenance of the chassis, drive train, and other components that comprise of the vehicle portion of this motorhome.
- Inquire with your RV Dealer about important care and maintenance information.
- Contact TMC's Customer Care for questions and guidance regarding maintenance and important warranty and service information.

Maintenance Schedule

The following maintenance schedule contains information pertaining to the living quarters of this motorhome. Follow the vehicle manufacturer’s recommendations for servicing

and maintaining the vehicle (motorized) portion of this motorhome.

ITEM	EVERY TRIP	EVERY MONTH	EVERY 3 MONTHS	EVERY 6 MONTHS	EVERY YEAR	PRIOR TO STORAGE	AS REQUIRED	PROCEDURE TO BE PERFORMED:
Engine/Chassis	•			•			•	Maintenance schedules are minimum requirements. Heavy use, unusual temperatures or humidity, or other extreme conditions may require more frequent maintenance.
	•						•	Check engine oil and top off with type recommended by chassis manufacturer. Change oil and filter at recommended mileage intervals.
	•						•	Check fluid levels including: brake, steering, coolant, transmission, washer, etc. Top off reservoirs as needed with fluids recommended by chassis manufacturer.
				•			•	Inspect underneath engine and transmission for leaks. Repair as necessary.
					•		•	Inspect air and fuel filters and replace at interval recommended by chassis manufacturer.
						•	•	Inspect chassis battery, terminals and cables. Repair and replace as necessary.
	•						•	Inspect suspension, steering components, exhaust systems etc. Repair and replace as necessary.
Brakes	•		•			•	•	Generator exhaust: inspect for cracks, blockages, damage. Replace immediately if any faults are discovered.
				•			•	Check fluid levels. Top off reservoir as needed with fluid specified by chassis manufacturer and only from an unopened container.
	•				•		•	Inspect pads and rotors. Replace as necessary.
	•						•	Inspect parking brake for proper function. Repair and replace as necessary.
	•						•	Inspect brake lights and turn signals for proper function. Repair and replace components as needed.
Weight Distribution	•						•	Inspect brake controller (towing) for proper function. Repair and replace as needed. Note: typically not factory installed.
							•	Check for proper weight distribution of equipment and components. Place heavy items as near and over axles as possible.
Tires	•						•	Weigh loaded motorhome with vehicle scales to determine loading. Do not overload vehicle per GAWR and GVWR ratings (see manufacturers specifications).
	•						•	Inspect for proper inflation (PSI). Inflate to proper cold pressure (PSI). Inspect for wear. Repair or replace ONLY with tire(s) of proper size and load rating. Unusual wear patterns indicate problems that should be addressed by qualified technicians.
	•						•	Check all wheel lug nuts and tighten using a properly calibrated torque wrench. Torque per chassis manufacturers specifications.
							•	Inspect spare tire for proper inflation (PSI). Inspect for cracking, aging. Replace as necessary.

ITEM	EVERY TRIP	EVERY MONTH	EVERY 3 MONTHS	EVERY 6 MONTHS	EVERY YEAR	PRIOR TO STORAGE	AS REQUIRED	PROCEDURE TO BE PERFORMED:
Wheel Alignment							•	Maintenance schedules are minimum requirements. Heavy use, unusual temperatures or humidity, or other extreme conditions may require more frequent maintenance. Inspect tires for uneven wear, dents in the wheel rims, and if vehicle steering seems unusual. All are indications that front wheels need re-aligned. Align as needed with a fully loaded vehicle and only by qualified technicians.
Exterior: mirrors, vision systems	•						•	Inspect rear-view mirrors and adjust when needed. Replaced broken mirrors and components promptly. Inspect rear and side-view vision systems for proper operation. Repair and replace components promptly.
Safety Equipment		•			•			Test smoke alarm. Replace battery annually.
		•			•			Test combination LP/Carbon Monoxide alarm. Replace promptly if found to be inoperable.
				•			•	Inspect fire extinguisher for proper pressure. Replace if low or after any use.
Seatbelts			•				•	Inspect driver and front passenger lap and shoulder belts for wear or defective latches. Replace worn or defective components promptly.
	•		•				•	Inspect all passenger seatbelts and latches and replace worn or defective components promptly.
	•		•				•	Inspect child safety harness brackets and tighten bolts if loose. Replace faulty components promptly.
Exterior: windows, doors, seals	•						•	Inspect windshield for cracks, chips, and damaged seals. Repair and replace as needed.
			•				•	Check door and window seals for damage. Repair as needed.
					•			Lubricate hinges, locks, & strike pockets of entrance, storage, and maintenance access doors.
							•	Inspect external corner and edge molding for damage; repair and reseal as needed.
					•		•	Inspect and replace wiper blades and windshield washer system components as needed.
Exterior surfaces			•					Wash surface with warm water and mild detergent. Do not use solvents or abrasive cleaners.
					•			Wax with liquid or paste non-abrasive automotive wax.
Exterior: roof			•			•	•	Inspect and reseal roof and component attachments; vents, antennas, ladders, HVAC, etc.
			•			•	•	Clean roof surface with warm water and mild detergent.
					•		•	Lubricate fan and power vent mechanisms with light oil. Clean surfaces as needed.
					•		•	Inspect air-conditioner(s) housing, mounting, condensation drains, etc. Repair and replace as needed.
					•		•	Inspect ladders for broken rungs, loose mounting components and bent rails. Replace as needed.
Exterior: lights	•						•	Inspect running, clearance, side-marker lights and repair or replace as needed.

ITEM	EVERY TRIP	EVERY MONTH	EVERY 3 MONTHS	EVERY 6 MONTHS	EVERY YEAR	PRIOR TO STORAGE	AS REQUIRED	PROCEDURE TO BE PERFORMED: Maintenance schedules are minimum requirements. Heavy use, unusual temperatures or humidity, or other extreme conditions may require more frequent maintenance.
Awning	•						•	Operate awnings to ensure proper functioning.
			•				•	Clean awning fabric with warm water and mild detergent. Allow fabric to dry before retracting. Lubricate hinges and joints with silicone grease.
Stabilizers: electric (if installed)	•						•	Ensure stabilizers deploy properly and fully retract. Clean deployment mechanism with mild detergent and rinse with water. Lightly lubricate as needed. Inspect jack pads for damage. Replace worn or damaged components as needed.
Cab/Cockpit	•						•	Vehicle horn: test for proper function, repair if defective.
	•						•	Gauges and switches: ensure all vehicle control functions and driver aids are in proper working order before every trip. Repair and replace as needed.
							•	Cockpit seating: lubricate mechanisms, repair or replace damaged seats or seating components.
							•	Inspect heater and air-conditioner for proper function. Repair as necessary.
Electrical System: 12-volt			•				•	Check and service auxiliary and chassis battery(ies). Add ONLY distilled water as needed or replace batteries that fail to hold a charge. Do not attempt to open maintenance-free batteries. Keep batteries on trickle charge when stored for an extended period of time.
					•		•	Check battery charging system: chassis alternator, inverter/converter, solar controller. Ensure proper charging voltage via multimeter reading (battery manufacturers charging recommendations).
	•							Multiplex system (if installed): check using 'Hot Skin Test'; with a multimeter set to 12-volts, place one probe on main panel and one probe to a known ground. There should be no voltage. If voltage is present, have multiplex system inspected by a qualified technician.
	•							Interior 12-volt lighting: repair and replace as needed.
							•	Check 12-volt power plugs, USB ports and electronic device charging stations. Repair or replace as needed.
					•			Inspect automatic transfer switch (ATC), inverter, and converter for proper function. Replace fuses or faulty circuit breakers.
	•							Inspect radio, navigation, and camera monitoring system. Repair as needed.
					•			Inspect towing electrical plug (4-way or 7-way). Apply electrical contact spray or electrical contact grease to contact surfaces.
				•				Solar panels (if installed): clean solar panels with water spray and soft cloth (do not use detergents or abrasive cleaners).
			•					Periodically check for BMPro multiplex software and firmware updates. Follow manufacturer's instructions for downloads.
		•		•			If equipped, inspect the lithium battery power system for signs of wear, overheating, frayed wires, or fatigue. Consult the manufacturer's manual for maintenance details.	

ITEM	EVERY TRIP	EVERY MONTH	EVERY 3 MONTHS	EVERY 6 MONTHS	EVERY YEAR	PRIOR TO STORAGE	AS REQUIRED	PROCEDURE TO BE PERFORMED:
Electrical System: 120-volt							•	Maintenance schedules are minimum requirements. Heavy use, unusual temperatures or humidity, or other extreme conditions may require more frequent maintenance.
	•						•	Inspect fuses and circuit breakers at the fuse box or circuit breaker panel. Replace blown fuses ONLY with type and rating indicated on the panel. Have a qualified electrician inspect circuits associated with blown fuses or circuit breakers to determine if additional repairs are required.
		•					•	Inspect shore cords, receptacles, extension cords for damage. Repair or replace as necessary.
		•						Generator: perform maintenance procedures per manufacturers recommendations. Check generator engine oil level regularly and top off as needed with oil type recommended by manufacturer. Check air filter and spark plug, replace as needed.
								Test ground fault circuit interruption (GFCI) receptacle(s) to ensure their proper function.
Propane System				•				Inspect 120-volt electrical receptacles. Repair and replace as necessary.
					•			LP tank, pipes, fittings: check for leaks and damage by using a mild soapy solution to detect leaks. Tighten fittings and/or repair as necessary.
							•	LP line pressure: inspect and check tank and gas line pressures by a qualified LP technician.
Water System			•				•	LP tank purge (new tanks): purge tank of inert gas and fill with propane at certified propane dealer and/or supplier.
	•						•	Water hoses, pipes, and fittings: inspect for leaks or damage. Repair or replace as necessary.
	•						•	Bathroom and kitchen fixtures: inspect toilet(s), sinks, shower, and faucets for leaks and damage. Repair as necessary.
	•						•	Water pump: ensure proper operation. Repair as necessary.
			•				•	Wastewater system: inspect drains and holding tanks. Repair clogs. Inspect termination valves and caps. Repair leaks and replace damaged components as necessary.
			•				•	Water heater: inspect for leaks. Inspect gas line for leaks. Inspect inlet and exhaust for insect nests or other restrictions. Repair and replace damaged components. DO NOT SANITIZE.
				•			•	Inspect water supply hose, water filter(s), water pressure regulator, water service hose, and sewer hose for damage. Repair and replace as necessary.
					•	•	•	Sanitize and flush freshwater system.
Heating System						•	•	Winterize fresh and wastewater systems.
	•				•		•	LP (gas) furnace/water heater: inspect for function. Inspect exhaust ports for restrictions. Have qualified service technician inspect furnace annually. Repair and/or replace faulty components immediately.
air-conditioner	•				•		•	Inspect for proper function. Inspect and clean filters. Repair or replace faulty components as necessary.

ITEM	EVERY TRIP	EVERY MONTH	EVERY 3 MONTHS	EVERY 6 MONTHS	EVERY YEAR	PRIOR TO STORAGE	AS REQUIRED	PROCEDURE TO BE PERFORMED: Maintenance schedules are minimum requirements. Heavy use, unusual temperatures or humidity, or other extreme conditions may require more frequent maintenance.
Appliances: LP (gas)	•						•	Check ranges, ovens, refrigerators for proper functioning. Repair gas leaks immediately.
Appliances: electric	•						•	Check microwave, refrigerator, fans and vents. Repair or replace as necessary.
Entertainment Systems			•				•	Inspect TV's, radios, DVD player, sound systems, WIFI extender, lifts, and mounting brackets. Repair and replace as necessary.
Beds, Bunks	•						•	Bed conversions: inspect for broken or damaged brackets. Lightly oil hinges and joints. Repair and/or replace damaged components.
Furniture							•	Inspect sofas, dinettes, tables, etc. Repair or replace damaged components.
Fabrics and Upholstery							•	Clean with mild household detergents and upholstery cleaners.
Countertops							•	Clean with mild, non-abrasive household cleaners and soft cloths.
Bath Fixtures, Sinks							•	Clean with mild, non-abrasive household cleaners and soft cloths.
Carpets, Flooring							•	Vacuum and mop and shampoo as necessary. Use water sparingly and wipe-up immediately.

This page is intentionally blank

Index

4G LTE, 57
 4-way connector wiring, 44
 5G networks, 58
 5G System, 57, 58
 7-Way Connector, 44
 12 Volt Fuse Panel, 131
 12 Volt Power System, 89
 30 Amp, 120 Volt Shoreline Power Cord, 124
 100 Amp Inverter Circuit Breaker, 98
 120 Volt Power System, 123

A

About This Owner's Manual, 9
 AGM, 91, 100
 AGS, 126, 128, 129
 Air-conditioning, 175
 Air-conditioning, Cabinet, 175
 Alterer Label (Canada), 41
 Alterer Label (USA), 39
 Android, 76, 77, 78
 Appliances, 52
 Aqua-Hot Gen 1 Combination Furnace/ Water Heater, 167
 Aqua-Hot Gen 1 Furnace/Water Heater, 167
 ASME, 136, 137
 ATC Blade-Style Fuse, 131
 Automatic Generator Start (AGS), 128
 Automatic Transfer Switch, 129
 Auxiliary Battery (lead-acid), 90
 Auxiliary Solar Panel Port, 95
 Awning, 47
 Awning, Extending, 47
 Awning, Retracting, 47

B

Basic Operation Guides, 11
 Basic Rules of Fire Safety, 20
 Bathroom and Bath Fixtures, 146
 Battery Access, 91
 Battery Charging, 92
 Battery Charging, Alternator, 92
 Battery Charging, Converter, 92
 Battery Charging, Solar Energy, 92
 Battery Maintenance, Lead Acid Type, 96
 Battery Storage, 97
 Battery Storage, Lead Acid, 97
 Battery temperature, 108

Beds and Bunks, 59
 Bicycle Rack, 49
 Black Tank Rinse, 158
 BPro, 72, 73
 BPro Cloud, 85
 BPro RVDM50, 71, 80
 BMV-712, 106, 107, 108

C

Cable TV Hook-up, 55
 California Formaldehyde Compliance, 31
 Campsite Sewer Hook-up, 155
 Canadian Cargo Carrying Capacity Label, 40
 Canadian Recreational Vehicle Length Label, 41
 Canadian Weight Label, 40
 Carbon Monoxide, 22, 24
 Carbon Monoxide (CO), 22
 Care and Maintenance, 159, 177
 Cargo Weight, 37
 Ceiling Fans, 175
 Change of Address, 14
 Change of Ownership, 14
 Changing a Damaged Tire, 35
 Charging by Solar Energy, 92
 Chassis Alternator, 91
 Chassis Manufacturers Notice, 17
 Chassis Owner's Manual, 9
 Chemical off-gassing, 31
 Chemical Sensitivity, 31
 Child Passenger Safety, 27
 Chlorine bleach, 150
 Circuit Breaker Panel, 130
 City Water Connection, 143
 Cleaning Interior and Exterior Surfaces, 178
 Clearance and Side Marker Lights, 29
 CMVSS 226, 41
 CMVSS Label, 41
 COAX, 56
 Combi, 139, 160, 169
 CombiMaster, 100, 114, 119, 120, 121, 122
 Combination CO/LP Alarm, 24
 Condensation, 178
 Condensation, Controlling, 178
 Consumer Information, 13
 Consumer's Responsibilities, 13
 Control Panels, 72
 Convenience Tables, 61
 Converter, 131
 Cooktops, 53

CR2032, 86
 Curb Weight, 37
 Customer Care, 9

D

Dash Radio, 55
 Dealer's Responsibilities, 13
 De-winterizing the Water System, 152
 Dinette Tables, 60
 Draining the Water Container, 165
 Driver and Front Passenger Seating, 26
 Driving the Motorhome, 30

E

EasyView 5, 102, 112, 121, 122
 Eclipse, 76, 77
 Electrical Connections for Towing, 44
 Electrical System, 89
 ELECTRIC Menu, 75
 Emergency (Auxiliary) Start Switch, 91
 Emergency Exit, 25, 31
 Emergency or Weekend Contact, 15
 Emergency Stopping, 29
 Engine Auto-Start Charging System, 115
 Entertainment Systems, 55
 Entry Step, 48
 Exhaust Fumes, 22
 Exhaust Gases, 22
 Extender, 57
 Exterior, 47

F

FANS Menu, 75
 Federal Weight Label, 38
 Federal Weight Label (USA), 38
 Fire Extinguisher, 20
 Firefly Diagnostic Tools, 79
 Firefly Integrations, 71, 73, 79, 86
 Firefly Phone App, 76
 Fire Safety, 19
 Ford Transit Van, 109
 Formaldehyde, 31
 Freshwater Filter, 146
 Freshwater Holding Tank, 144
 Freshwater Holding Tank, Drain Valve, 145
 Freshwater System, 143
 Front Airbags, 26
 Fuel System Safety, 25
 Furnace, 149

INDEX

Furnace/Water Heater Combo, 147
 Furnace/Water Heater Controller, 169
 Fuse Panel, 131

G

gas shut-off valve., 140
 Gas Shut-off Valve, 139, 162
 GAS shut-off valve, 140
 GAWR, 38, 40, 42, 43, 183
 GCWR, 37, 38, 39, 43, 45
 General Maintenance, 177
 Generator, 71, 80, 126, 127, 128, 129, 181, 183, 186
 Generator, Automatic Generator Start (AGS), 128
 Generator, Starting and Stopping Procedures, 127
 GFCI Receptacle, 133
 Go Power PWM, 94
 Gravity Fill Port, 144
 Gray Wastewater Tank, Emptying, 156
 Gross Axle Weight (GAW), 38
 Gross Axle Weight Rating (GAWR), 38
 Gross Combined Weight (GCW), 38
 Gross Combined Weight Rating (GCWR), 38
 Gross Vehicle Weight (GVW), 37
 Gross Vehicle Weight Rating (GVWR), 37
 GVW, 37, 38
 GVWR), 37, 38, 40

H

HDMI, 55, 56
 Holding Tank Heaters, 149
 HOME Menu, 75
 HVAC, 71

I

Idle Speed Control, Ford Transit, 109
 Inhibiting Mold Growth, 177
 Instructional Videos, 11
 Interior, 51
 Interior Lighting, 51
 Introduction, 9
 Inverter, Non Li-Ion Systems, 97
 iOS, 76, 77

K

Kitchen Sink, 146

L

Lagun Table System, 62
 Laws of the Road, 29
 LiFePO₄, 100, 101, 105, 115
 Light Bar, 48
 LIGHTING Menu, 75
 Lithium Iron Phosphate, 100
 Loading Your Motorhome, 43
 Load Shedding, 103, 112
 Lockable Storage, 64
 Long-term Storage, 180
 Long-term Storage of the Re(Li)able 200, 300, 400 Ah Battery Systems, 119
 Long-term Storage of the Re(Li)able 460 and 920 Ah Battery Systems, 121
 Low Point Drain Valves, 148
 Lug Nut Torque, 35

M

Mailing Address, TMC, 14
 Main Electrical Panels, 73
 Maintenance, Chassis (Vehicle), 177
 Maintenance Schedule, 183
 MasterAdjust, 118
 Master Battery Switch, 89
 MasterBus, 101, 113, 115, 118
 MasterBus-USB, 118
 Mastervolt, 99, 100, 101, 102, 104, 105, 112, 113, 114, 115, 118, 119, 120, 121, 122
 Mastervolt EasyView 5 System Controller, 112
 Mastervolt Smart Remote Monitor, 104
 Maximum Loaded Trailer Weight, 38
 Microwave Oven, 54
 Midpoint voltage deviation, 108
 Mira, 76, 77
 Mirrors, 28
 Mirrors and Vision Systems, 28
 Mold Prevention, 177
 Multiplex, Basic Operation, 74
 Multiplex Control Systems, 71
 Multiplex, Firefly Lyra Screen, 75
 Multiplex, Integrated Solar Charging Systems, 94
 Multiplex, Remote Control, 74
 Multiplex, Remote Switches, 86
 Multiplex, System Diagram, 81

N

NHTSA, 17, 28, 33, 36, 38

O

Obtaining Assistance, 14
 Obtaining Service at TMC, 14
 OCCC, 37, 39, 43, 154
 OCCC Weight Label, 39
 Occupant and Cargo Carrying Capacity (OCCC), 37
 Online Customer Support, 10
 Operating Interior Lights, 51
 OTA, 56, 57
 Over-cab Storage, 63
 Over-the-Air TV, 55
 Owner's Packet, 9, 13, 49, 55, 57, 105, 114, 127, 128, 147, 148, 159, 160, 168, 175
 Owners Resource, 10
 Owners Resource QR Code, 11

P

P65Warnings, 31
 Pop-top Sleeping Bunk, 65
 Potable Water Hose, 143
 Power Load Center, 98
 Power Load Center: 30 Amp, 130
 Pressure Relief/Drain Valve, 162, 163
 Propane, External Hook-up, 139
 Propane, Furnace/Water Heater Gas Shut-off Valve, 139
 Propane Gas Safety, 22, 135
 Propane, Leak Test, 141
 Propane, Main Gas Valve, 138
 Propane, Monitoring Propane Levels, 137
 Propane Safety, 23
 Propane System, 135
 Propane Tank, 137
 Propane Tank, Filling and Servicing, 137
 PSI, 33, 38, 40, 167, 183

R

Rapid Camp+, 71
 Rear Door Screen, 49
 Receptacle, GFCI, 133
 Receptacle, Outside 120 Volt AC, 133
 Recreational Vehicle Privacy Notice, 16
 Refrigerator, 53
 Re(Li)able, Basic System Operation, 101

Re(Li)able Battery Power Systems, 99
 Re(Li)able V1, 460 Amp-Hour System, 111
 Re(Li)able V1 Energy, 100
 Re(Li)able V1 Energy System, 101
 Re(Li)able V1, Safety Relays, 113
 Re(Li)able V2 Energy, 100, 101
 Re(Li)able V2 Energy System, 101
 Re(Li)able V3, 200 Amp-Hour System, 102
 Re(Li)able V4 Energy System, 101
 Remote System Servicing, 118
 Replacement Parts, 15
 Reporting Safety Defects, 17
 Roof Air Conditioner, 174
 Roof Rack, 48
 RV-C, 71
 RVD50, 80
 RVD50 Control/Display, 80
 RVMaster App, 83
 RVMaster Node, 83, 84
 RVD50, 84

S

Safely Driving the Motorhome, 29, 30
 Safe Towing Tips, 45
 Safety Alerts, 19
 Safety Labels, 19
 Safety Nets, 69
 Safety Relay, 113, 115, 122
 Safety Relays, 113
 Sanitizing the Freshwater System, 150
 Seals and Sealants, 178
 Seatbelts, 26
 Service Repair, 15
 Shore Power, 123
 Shore Power, Connecting to, 124
 Shore Power, Cord Maintenance, 126
 Shore Power, Plug Adapters, 125
 Shore Power, Wiring Configuration, 125
 Side Door Screen, 48
 SkyBunk, 65
 Skybunk, Canvas Care, 69
 Skybunk, Lowering, 68
 Skybunk, Raising, 67
 Skybunk, Safety, 68
 Skylight, 65
 SmartRemote, 102, 104, 119, 120
 Smoke Alarm, 21
 Software, MasterAdjust, 118
 Solar Charging Controller, 10 amp, 93
 Solar Charging, Integrated Systems, 94

Solar Panel Port, 95
 Solar Panels, 95
 Spray Port, 146
 SSID, 57
 Starter battery voltage, 108
 Storage, 63
 Storage, Over-cab, 63
 Sunshade, 65
 Swivel Seating, 26
 System Guides, 10

T

Tables, 60
 Television, 55
 Termination Valves and Sewage Discharge, 154
 Tire Identification Information, 36
 Tire Inflation, 33
 Tire Inspection, 34
 Tire Pressures, 33
 Tire Replacement, 35
 Tire Safety, 33
 Tires and Wheels, 33
 Tire Wear Patterns, 34
 TMC Owner's Packet, 9
 TMC Warranty Guide, 9
 Toilet, 153
 Toilet, Cassette, 153
 Toilet, Cassette, Emptying, 157
 Toilet, Portable, 154
 Tongue Weight, 38
 Towing Capacity, 38
 Towing Hitch, 44
 Towing With Your Motorhome, 43
 Transport Canada, 17, 28
 Transporting Pets, 28
 Traveling With Propane, 136
 Truma, 139, 169
 Truma Combination Furnace/Water Heater, 159

U

Unloaded Vehicle Weight (UVW), 37
 Usage, Cold Weather, 178
 Usage, Extended Stay, 179

V

Vegatouch, 76, 77, 78, 79
 Vegatouch Eclipse, 76
 Vegatouch Mira, 76, 77
 Vehicle Identification Labels, 14
 Vehicle Identification Number, 10
 Vehicle Safety, 19

Ventilation, 31
 Ventilation Fans, 175
 Victron BMV-712, 104
 VictronConnect App, 106
 Victron Energy Battery Monitor, 106
 VIN, 10, 14, 39, 41
 Vision Systems, 28

W

Wastewater Holding Tanks, 154, 155
 Wastewater System, 153
 Water/Convenience Panel, 146
 Water Heater Bypass Valves, 148
 Water Pump, 145
 Water Pump, Strainer, 145
 Water System, 143
 Water System, Cold Weather Use, 149
 Website Disclaimers, 16
 Weighing, Loading, and Towing, 37
 Weighing Your Motorhome, 42
 Weight Distribution, 43
 Weight Terminology, 37
 Wheel Alignment, 35
 Wi-Fi Connectivity, 57, 58
 Wi-Fi Extender, 58
 WiFi Extender, 57
 Winegard 4G 2.0, 87
 Winegard Connect 2.0, 57
 Winterizing, 11, 148, 151, 165, 168
 Winterizing the Water System, 151
 Wireless Switch Panels, 72
 Work Surface Tables, 60

This page is intentionally blank



Made to fit.

thormotorcoach.com

TMC Part Number 0562645
Revision Date 05.01.2024